

MOVEMENT SPECIFICATIONS  
**CAL.FS60/61**  
**10-1/2 LIGNE, 3 EYES CHRONOGRAPH**  
**ANALOGUE QUARTZ, 0 JEWEL**

MANUFACTURED IN JAPAN

**1.BASIC SPECIFICATIONS**

(1) CaL. No.

\*TO CONFIRM WITH MOV'T DRAWING ATTACHED

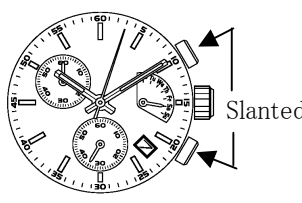
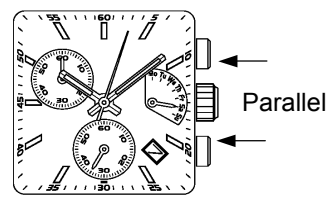
CALIBRE	<b>FS60</b>	<b>FS61</b>
PUSHER	<b>SLANTED</b>	<b>PARALLEL</b>
Ligne	10-1/2	
Size*mm	Φ 23.7X22mm (3H-9H)	
Date	0	
<b>Total height</b>	<b>5.10mm</b>	<b>5.25mm</b>
Figure (push button placed angle)	 FS60	 FS61
Battery & Life	<b>SR626SW 2YEARS*</b>	

\* based on 1 hour/day chronograph use

(2) Time standard

Type of quartz : Tuning fork type quartz crystal

Frequency : 32,768Hz

Accuracy : **+/-20 s/month** worn under normal circumstances

(3) Balanceable weight of hand

Minute hand Max. 0.4 μN.m

Second hand Max. 0.035 μN.m

Other small hands Max. 0.02 μN.m

(4) Function

**Chronograph 1/1 sec. Basis (Up to 59 min. 59 sec.)**

Powercell Saving Reset Mechanism(PSRM)

Over-loading Compensation Device(OLCD)

Digital Frequency Control(DFC) for time adjustment

**FS60 / FS61 (EYE POSITION)**

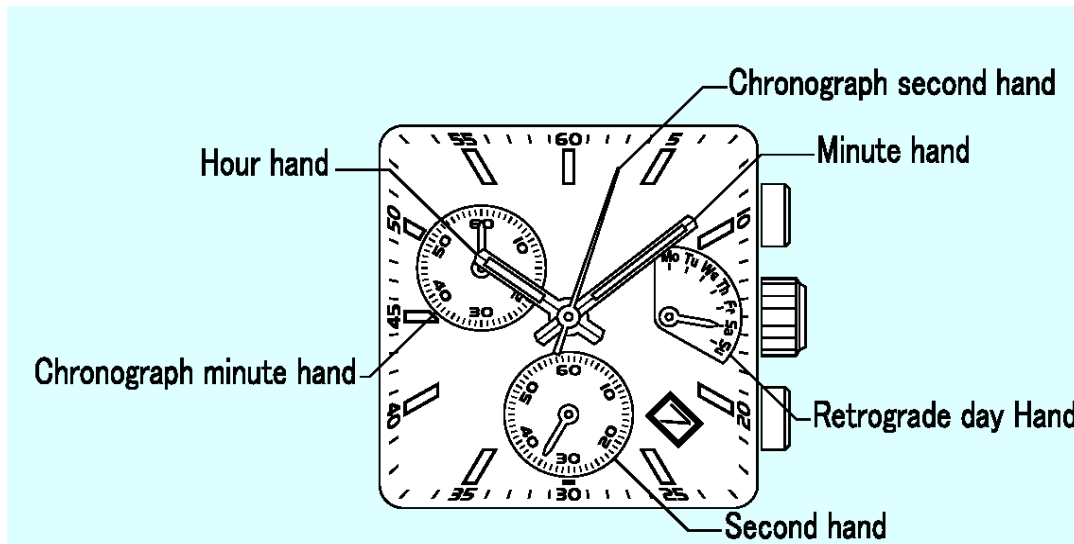

## 2.SEPARATED PARTS

### Setting stem x1

Code	065-549
Length from movement center to far end of setting stem	20.00mm
Thread.....	Φ0.9mm x 9.06mm

## 3.OTHERS

### \* Measurement of time rate

The unit(gate) time of measurement must be set at "10 sec." or integer fold value of 10 sec. owing to the DFC system, and the measurement must be performed in the form of complete watch.

### \* Marking on movement

	<b>JAPAN</b>
	<b>MIYOTA CO.</b>
FS60/61	<b>(CAL. NO.)</b>
	<b>NO JEWELS</b>

### \* Typical clearance

Mov't - Caseback	minimum 200 microns
Top of hands - Glass	300 - 400 microns *
* subject to the glass, case structure, and the length of hand	

### \* Note

**Please use aluminum material hand for Chrono second hand**

### \* TACHYMETER

The tachymeter is the device which measures the speed of an automobile. Knowing is how many seconds the car covers a distance of 1km, the meter can measure the approximate average speed per hour during a journey (up to the maximum measurable range of tachymeter is 60 seconds.)

If the chronograph is started at the same time as measurement, and stopped after 1 km, the average speed per hour can be determined according to the position of the second hand. If the car covers the distance of 1km in 45 seconds, the average hourly speed during the journey will be about 80 km.

4 INSTRUCTION MANUAL

A) DISPLAYS AND BUTTONS

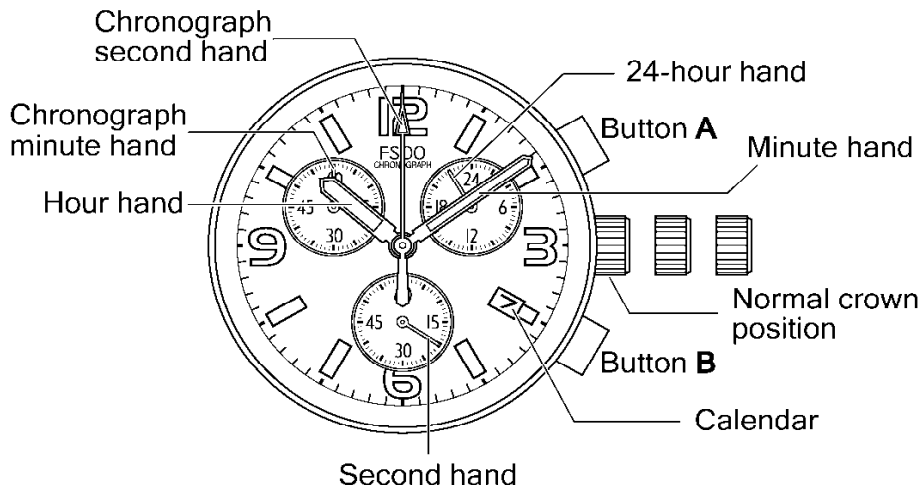

B) SETTING THE TIME

1. Pull the crown out to the 2nd-click position so that the second hand stops at (0) position.
2. Turn the crown to set the hour and minute hands.

C) SETTING THE DATE

1. Pull the crown out to the 1st position.
2. Turn the crown by clockwise to set the date.
  - \* If the date is set between the hours of around 9:00 PM and 1:00 AM, the date may not change on the following day.
3. After the date has been set, push the crown back to the normal position.

D) USING THE CHRONOGRAPH

This chronograph is able to measure and display time in 1/1 second united up to maximum of 1 hour.

Measuring time with the chronograph

1. The chronograph can be started and stopped each time button "A" is pressed.
2. To reset, press button "B" and the chronograph second & minute hands return to their 0 positions.

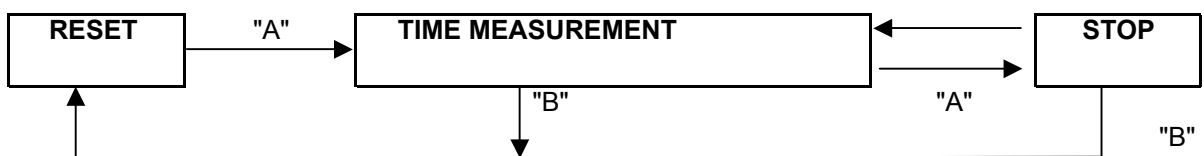
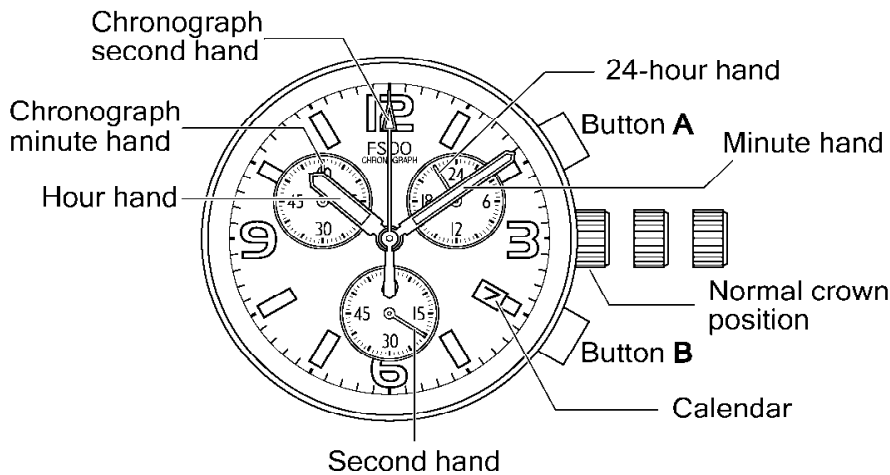

#### E) CHRONOGRAPH RESET (INCL. AFTER REPLACING BATTERY)

This procedure should be performed when the chronograph second hand do not return to the 0 second position after the chronograph has been reset, and including after the battery has been replaced.

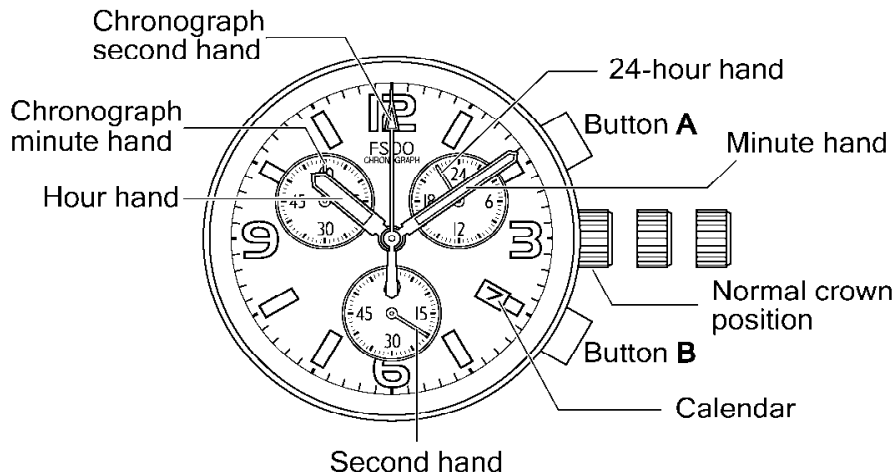

1. Pull the crown out to the 2nd position.
2. Press button "A" to set the chronograph second hand to the 0 position.
3. The chronograph hands can be advanced rapidly by continuously pressing button "A".
4. Once the hands have been zeroed, reset the time and return the crown to its normal position.

\* Do not return crown to normal position while chronograph second hand return to 12:00 (ZERO) position.

Hand stops on the way when crown are returned to normal position and these positions are recognized as 12:00 (ZERO) position.

#### F) FITTING METHOD OF HANDS

Place the module on case back shown in the figure and position the reference hand, then fit the hands according to the following procedure.

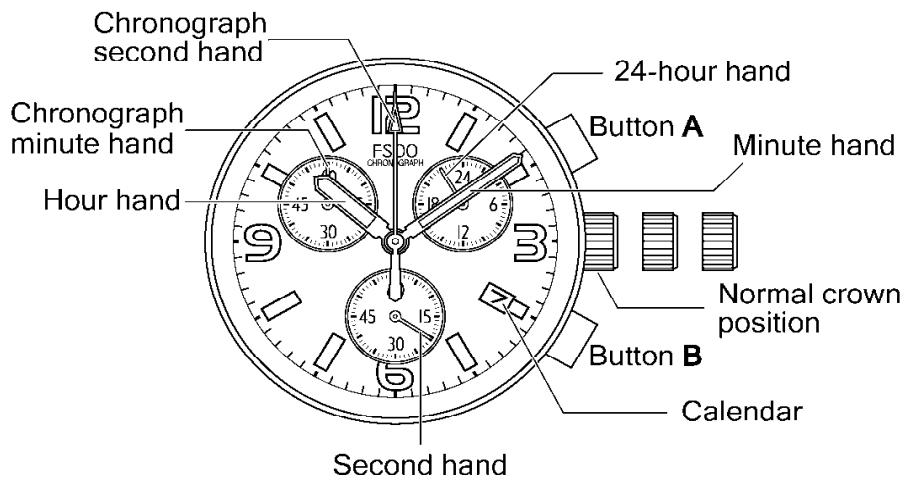

1. After the dial assembling, push A first and then B to make sure all the hands is not moving.
  2. Pull out the crown to the time setting position.
  3. Turn the crown anticlockwise, and stop it just after the date changes. (When the date starts changing, turn the crown very slowly. And stop it when it changes the date.)
  4. Push in the crown by one step, taking care not to turn it.
  5. Fit the reference hand, hour hand and minute hand to the 12-o'clock position.
- When fitting the hands, remove the case back and place the movement on work stand.

***This specifications might be changed without prior notice.***