



4 1/4'''



Cal. 1042

## 1. Werkdimensionen

## 1. Dimensions des mouvements

## 1. Movement dimensions

Kaliber	Ø Total	Ø Werksitz	Werkhöhe	Höhe Batterie	Höhe Stellwelle	Höhe Werkauflage
Calibre	Ø Total	Ø Encageage	Hauteur mouvement	Hauteur pile	Hauteur tige	Hauteur filet
Caliber	Ø Total	Ø Case fitting	Movement height	Height of battery	Height of stem	Movement rest
Unit	mm	mm	mm	mm	mm	mm
<b>1042</b>	10,40	10,00	2,90	2,90	0,55	0,30
Stellwellengewinde / Filetage de la tige / Stem thread : Ø 0,70mm				Weg / Chemin / Length of travel 0.33mm		

## 2. Funktionen

## 2. Fonctions

## 2. Functions

Kaliber	Stellwellenpos.	Funktionen
Calibre	Pos. de tige	Fonctions
Caliber	Stem position	Functions
1042	1	Normale Position / Position normale / Running position
	2	Zeiger stellen / Mise à l'heure / Hand setting

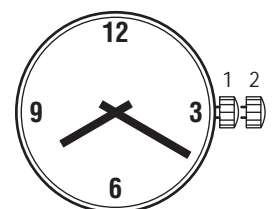

# Werkaufbau

# Assemblage

# Assembling

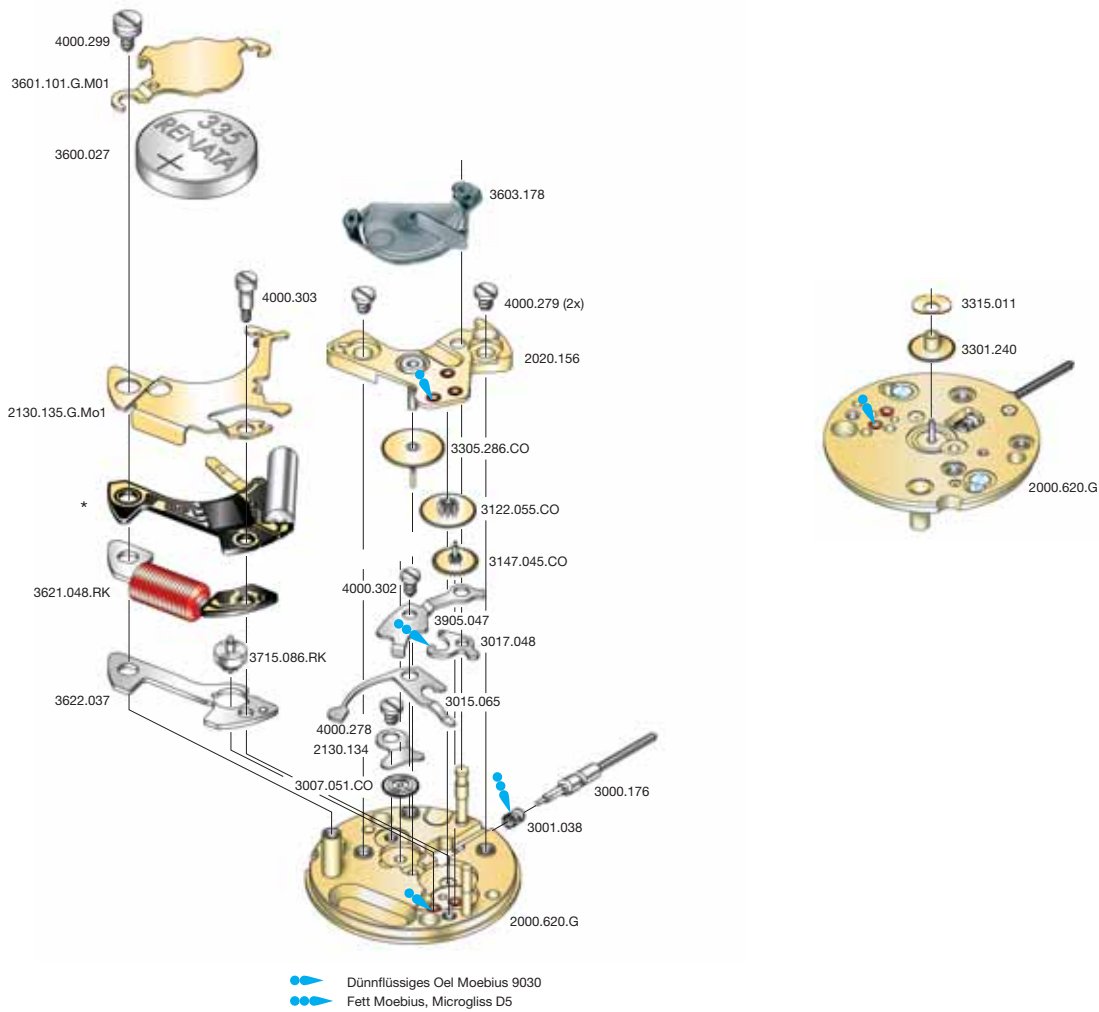

4 1/4''' 1042

4 1/4''' 1042



Plan No.	Bestandteile	Fournitures	Spare Parts
2000.620.G	Werkplatte	Platine	Main plate
2020.156	Räderwerkbrücke	Pont rouage	Train w. bridge
2130.134	Zeigerw.haltepl.	Plaque maintien	Maintaining plate
2130.135.G.M01	Modul Abdeckpl.	Couvre module	Module cover pl.
3000.176	Stellwelle	Tige	Stem
3001.038	Kupplungstrieb	Pignon coulant	Sliding pinion
3007.051.CO	Wechselrad	Minuterie	Minute wheel
3015.065	Wippe	Bascule	Yoke
3017.048	Stellhebel	Tirette	Setting lever
3122.055.CO	Kleinbodenrad	Roue moyenne	Third wheel
3147.045.CO	Zwischenrad	Roue intermed.	Intermed. wheel
3305.286.CO	Minutenrohr	Chaussée	Cannon pinion
3600.027	Batterie	Pile	Battery
3601.101.G.M01	Batteriehalter(+)	Bride pile(+)	Battery clamp(+)
3603.178	Batt.Isolation	Isolateur pile	Battery insulation
*	Modul	Module	Module
3621.048.RK	Spule	Bobine	Coil
3622.037	Stator	Stator	Stator
3715.086.RK	Rotor	Rotor	Rotor
3905.047	Winkelhebelfeder	Ressort tirette	Setting lever spr.
4000.278	Schraube	Vis	Screw
4000.279	Schraube	Vis	Screw
4000.299	Schraube	Vis	Screw
4000.302	Schraube	Vis	Screw
4000.303	Schraube	Vis	Screw

Cal. 1042	Zifferblattseite / Côté cadran / Dial side		
Plan No.	Bestandteile	Fournitures	Spare Parts
3301.240	Stundenrad	Canon	Hour wheel
3315.011	Sprezfeder	Clinquant	Washer

* Modul (alt) Module (vielle) Module (old)	* Modul (neu) Module (nouvelle) Module (new)
3612.135	3612.157
	

grün  
vert  
green

### Batterien / Piles / Batteries

1042	Nr. 335 Dim. Ø x H:	SR 512 SW 5,80 x 1,25
------	------------------------	--------------------------

### 3. Leistungen

### 3. Performances

### 3. Performances

Kaliber Calibre Caliber	Bedingungen Conditions Conditions	Momentaner Gang March instantanée Instantaneous rate	Stromaufnahme Consommation courant Power consumption	Drehmoment Couple utile Torque	Gangreserve Autonomie Autonomy
1042	Einheit / Unité / Unit Typ.Wert / Valeur / value	Mi (s/month)	I (µA)	T (µNm) min.	A (Monat/mois/month)
* Modul 3612.135	1,55 V    23°C Batt./ Pile    5,5 mAh	- 10/+ 20	0,31    < 0,35	17,1	24
* Modul 3612.157	1,55 V    23°C Batt./ Pile    5,5 mAh	- 10/+ 20	0,21    < 0,30	14,0	36
Magnetfeldabschirmung / Résist. aux champs magn. / Resist. to magnetic fields			18,8 Oe	1500 A/M	Norm 
Betriebstemperatur / Température d'opération / Operating temperature			0-50°C		
Schockresistenz / Résistance aux chocs/ Shock resistance			NIHS 91-10		

### 4. Elektr. Messungen

### 4. Contrôles électriques

### 4. Electrical checking

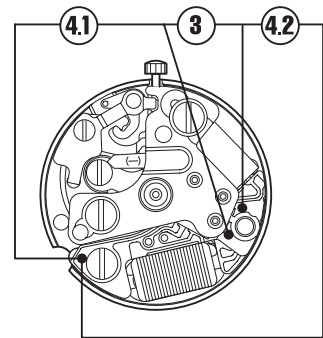
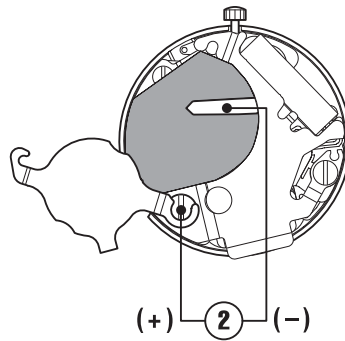
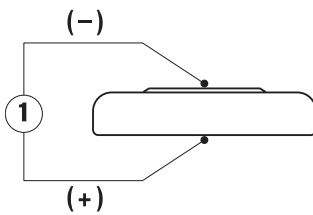

Kaliber Calibre Caliber	Pos. Pos. Pos.	Einheit Unité Unit	Messwerte Valeurs mesurées Measured values	Kontrolle Contrôle Check	Bemerkungen Remarques Remarks
1042	1	V	1,55	Batterie-Spannung Tension de la pile Battery voltage	Batterie herausnehmen und messen Enlever et mesurer la pile Remove battery for measuring
1042 * Modul 3612.135	2	µA **by pulses	0,31 < 0,35 < 3,5	Stromverbrauch ** (Puls Periode 20 Sek.) Consom. de courant ** (impulsions 20 sec.) Power consumption ** (pulse period 20 sec.)	Ohne Batterie, mit externer Speisung 1,55 V Sans pile, avec alimentation externe de 1,55 V Without battery, with ext. power supply 1,55 V
1042 * Modul 3612.157	2	µA **by pulses	0,20 < 0,30 < 3,5	Stromverbrauch ** (Puls Periode 20 Sek.) Consom. de courant ** (impulsions 20 sec.) Power consumption ** (pulse period 20 sec.)	Ohne Batterie, mit externer Speisung 1,55 V Sans pile, avec alimentation externe de 1,55 V Without battery, with ext. power supply 1,55 V
1042	2	V	≤ 1,30 V	Funktionskontrolle bei Minimalspannung Contrôle de fonctionnement à tension min. Operation with lowest possible voltage	Ohne Batterie, mit externer Speisung Sans pile, alimentation externe en Without battery, with external power supply
1042	3	KΩ	1,90	Spulenwiderstand Résistance de la bobine Coil resistance	Ohne Batterie Sans pile Without battery
1042	4.1 + 4.2	KΩ	∞	Spulenisolation Isolation de la bobine Coil insulation	Ohne Batterie Sans pile Without battery
1042		Sek. / Monat sec. / mois sec. / month		- 10/+ 20	Induktivsonde 60 Sekunden    Mit Batterie Senseur inductif 60 secondes    Avec pile Inductive sensor 60 seconds    With battery

## 5. Zeigerwerk

## 5. Aiguillage

## 5. Dial-train

Zeigerwerk	Einzelteil-Höhe	mm	Höhe ab Zifferblattauflage	mm	Ø Zeigeranpassung	mm	Zifferblattdicke	mm
Aiguillage	Hauteur de la pièce ind.	mm	Dépassement platine	mm	Ø Ajustement des aiguilles	mm	Epaisseur du cadran	mm
Height of dial train	Height of individ. piece	mm	Height from base	mm	Ø Adjustment of hands	mm	Dial thickness	mm
<b>1042</b>	<b>A</b>	<b>B</b>	<b>E</b>	<b>F</b>	<b>H</b>	<b>I</b>		
<b>0</b>	2,09	0,83	0,98	0,60	0,80	0,40	0,30	
<b>1</b>	2,29	1,03	1,18	0,80	0,80	0,40	0,40	

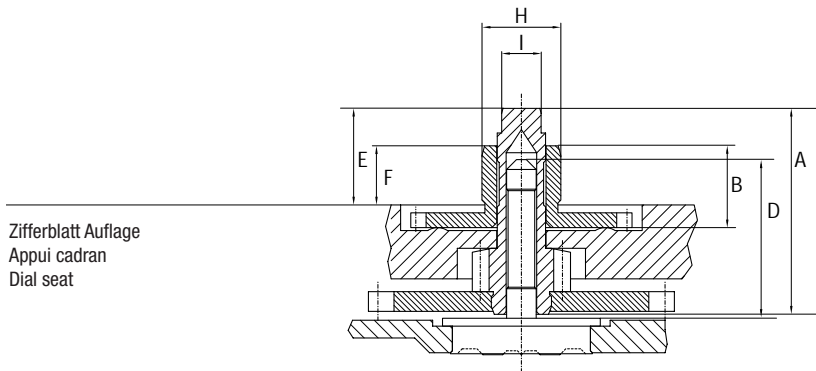

Für Einzelheiten verlangen Sie bitte die entsprechenden Zeigerwerkpläne!  
 Pour plus de détails demandez nos plans d'aiguillage!  
 For more detailed information please ask for the corresponding hand plans!

## 6. Einschalen / Werkzeuge

## 6. Emboîtement / outils

## 6. Casing / tools

Nr. H 1042.1A



### Zeigersetzen

Maximale Aufpresskraft:

– Stunden und Minutenzeiger: max. 40N

Beim Zeigersetzen muss das Werk abgestützt werden.

### Poser les aiguilles

Force de chassage maximale:

– Aiguilles des heure et des minutes: max. 40N

Lors de la pose d'aiguilles, le mouvement doit être soutenu.

### Hand setting

Maximal force:

– Hour and minute hands: max. 40N

The movement needs to be supported for hand setting.

Nr. H 1042.1T



### Stellwelle entfernen

Beim Entfernen der Stellwelle muss sich die Stellwelle in Position 1 (gedrückt) befinden, bevor auf den Winkelhebel gedrückt wird.

### Enlever la tige

En enlevant la tige, la tige doit se trouver en position 1 (poussée), avant de pousser sur la tirette.

### Stem removal

For removal of the stem, the stem must be pushed into position 1 (pressed in) prior to apply pressure to the setting lever.

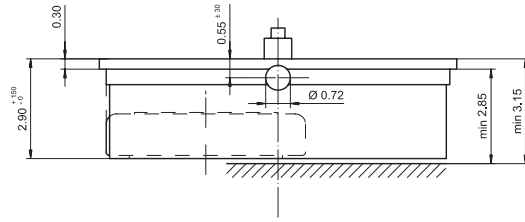

Seite Gehäuseboden  
Côté fond de boîte  
Case back side

Zifferblattseite  
Côte cadran  
Dial side

Zifferblattfüsse  
Pieds de cadran  
Dial feet

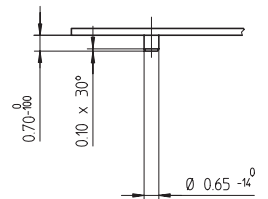
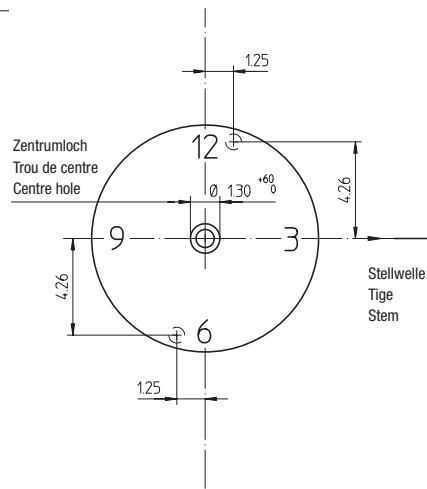
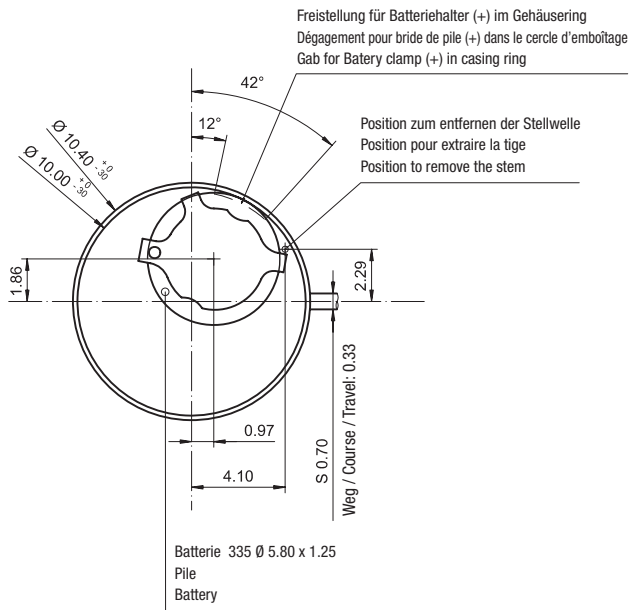

Sicherheitsabstand zwischen Minutenzeiger und Glas	0,30 mm
Sécurité entre aiguille minute et le verre	0,30 mm
Security between minute hand and glass	0,30 mm

Das Zifferblatt muss durch die Schale gehalten werden.  
Le cadran doit être tenu par la boîte.  
The dial must be hold by the case.