

SEIKO

QUARTZ

Cal. 9020, 9021, 9029

**PARTS
CATALOGUE**

Cal. 9020, 9021, 9029

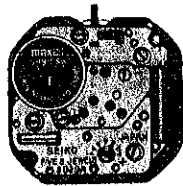

Cal. 9029A



122 856



125 854



☆221 842



☆221 843



☆221 845



231 855



☆241 845



241 853



261 856



☆271 845



☆271 848



281 856



282 855



282 858



354 856



383 855



384 855



389 855



391 856



491 589



491 840



604 854



701 855



737 855



766 855

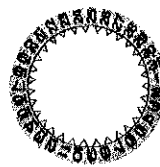

☆801 543



802 855



808 855



810 855

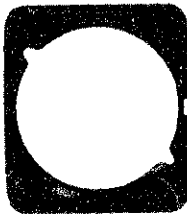

☆884 985



962 855



986 855



4001 851



4002 855



4050 876



4050 878



4050 882



4146 855



4216 858



4239 855



4259 855



4270 856



4271 855

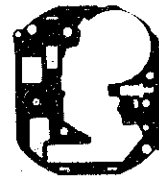

4408 856



4450 855



022 436



022 754

3/4



☆SEIKO TR916SW

Cal. 9020, 9021, 9029

Characteristics

	Cal. 9020	Cal. 9021	Cal. 9029
Casing diameter	φ 23.3 mm		
Maximum height (without battery)	1.8 mm		2.2 mm
Jewels	5 j		
Frequency of quartz crystal oscillator	32,768 Hz (Hz = Hertz Cycles per second)		
Driving system	Step motor (2 poles)		
Regulation system	Rotary step switch		
Train wheel setting	○	○	○
Calendar (Date)			○
Instant setting device			○
Battery life indicator		○	

PART NO.	PART NAME	PART NO.	PART NAME
122 856	Center wheel bridge	4050 882	Circuit bridge plate (Cal. 9021)
125 854	Train wheel bridge	4146 855	Step rotor
☆ 221 842	Center wheel & pinion (Cal. 9020)	4216 858	Insulator for battery
☆221 843	Center wheel & pinion (Cal. 9020,9029)	4239 855	Rotor stator
☆221 845	Center wheel & pinion (Cal. 9021)	4259 855	Anti-magnetic shield plate
☆221 853	Center wheel & pinion (Cal. 9029)	4270 856	Battery connection (-)
☆221 848	Center wheel & pinion (Cal. 9021)	4271 855	Battery connection (+)
☆221 857	Center wheel & pinion (Cal. 9021)	4408 854	Circuit block spacer (Cal. 9020,9021)
231 855	Third wheel & pinion	4408 856	Circuit block spacer (Cal. 9029)
☆ 241 845	Fourth wheel & pinion (Cal. 9021)	4450 855	Regulating switch lever
☆241 848	Fourth wheel & pinion (Cal. 9021)	011 568	Upper hole jewel for step rotor
☆241 853	Fourth wheel & pinion (Cal. 9020,9029)	011 570	Lower hole jewel for step rotor)
☆241 857	Fourth wheel & pinion (Cal. 9021)	011 570	Upper hole jewel for center wheel
261 856	Minute wheel	011 570	Upper hole jewel for third wheel
☆ 271 845	Hour wheel (Cal. 9020,9021)	011 570	Upper hole jewel for fourth wheel
☆271 846	Hour wheel (Cal. 9021)	022 436	Train wheel bridge screw
☆271 848	Hour wheel (Cal. 9029)	022 436	Circuit bridge plate screw
☆271 856	Hour wheel (Cal. 9021,9020)	022 436	Setting wheel plate complete screw
☆271 857	Hour wheel (Cal. 9029)	022 754	Date dial guard screw (Cal. 9029)
281 856	Setting wheel	023 340	Date corrector wheel rocking lever pin (Cal. 9029)
282 855	Clutch wheel (Cal. 9020,9021)		Date dial guard tube (Cal. 9029)
282 858	Clutch wheel (Cal. 9029)	023 377	Tube for setting wheel plate complete screw
354 856	Winding stem	027 127	
383 855	Setting lever		Tube for train wheel bridge
384 855	Yoke (Cal. 9020,9021)	027 134	Tube for circuit bridge (A)
384 856	Yoke (Cal. 9029)	☆027 145	Tube for circuit bridge (B)
389 855	Setting lever spring	☆027 157	Setting lever pin (Cal. 9020,9021)
391 856	Train wheel setting lever	027 744	Setting lever pin (Cal. 9029)
491 589	Dial washer (Cal. 9020,9021)	027 750	Train wheel setting lever pin
491 840	Dial washer (Cal. 9029)	027 745	Yoke pin
604 854	Setting wheel plate complete	027 746	Regulating switch lever pin
701 855	Fifth wheel & pinion	027 747	Silver oxide battery
737 855	Date corrector setting wheel (Cal. 9029)	☆Maxell SR916SW	Silver (II) oxide battery
766 855	Intermediate minute wheel	☆SEIKO TR916SW	
☆ 801 543	Date dial (Cal. 9029)		
802 855	Date driving wheel (Cal. 9029)		
808 855	Date dial guard (Cal. 9029)		
810 855	Date jumper (Cal. 9029)		
☆ 884 985	Holding ring for dial (Cal. 9029)		
962 855	Intermediate wheel for calendar correction (Cal. 9029)		
986 855	Date corrector wheel rocking lever (Cal. 9029)		
4001 851	Circuit block		
4002 855	Coil block		
4050 876	Circuit bridge plate (Cal. 9020)		
4050 878	Circuit bridge plate (Cal. 9029)		

☆⇨ Please see remarks on the reverse page.
Part numbers in light letters are not shown in photos.

Cal. 9020, 9021, 9029





Remarks :

Center wheel & pinion, Fourth wheel & pinion, Hour wheel

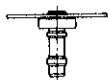

There are some different types as specified below.

Combination





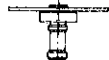

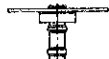
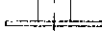
Cal. 9020

Type	Center wheel & pinion	Hour wheel
a	 ☆221 842	 ☆271 845
b	 ☆221 843	 ☆271 856

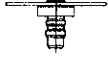
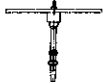
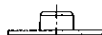
Cal. 9029

Type	Center wheel & pinion	Hour wheel
a	 ☆221 843	 ☆271 848
b	 ☆221 853	 ☆271 857

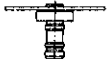
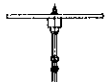
Cal. 9021

Type	Center wheel & pinion	Fourth wheel & pinion	Hour wheel
a	 ☆221 845	 ☆241 845	 ☆271 845
b	 ☆221 857	 ☆241 857	 ☆271 846
c	 ☆221 848	 ☆241 848	 ☆271 856

Date dial (Cal. 9029A)

☆801 543 (Black figures on silver background) } Used when both the crown and the calendar frame are located at 3 o'clock position.
 ☆801 547 (Black figures on gold background) }

If any other type of date dial is required, specify ① Cal. No. ② The crown position ③ The calendar frame position and ④ Dial No.

Holding ring for dial (Cal. 9029A)

☆884 985 The type of a holding ring for dial is determined based on the design of cases.

If the shape of holding ring for dial is different from the photograph, check the case number and refer to "SEIKO Quartz Casing Parts Catalogue" to choose a corresponding holding ring for dial.

Tube for circuit bridge (A), (B)

☆027 145 } Refer to the illustration on the right.
 ☆027 157 }



☆027 145



☆027 157

Battery

☆Maxell SR916SW } The substitutive battery might be added to the applied battery in the future.
 ☆SEIKO TR916SW }

In that case, please refer to separate "BATTERY LIST FOR SEIKO QUARTZ WATCHES".

Note that SEIKO battery is marked with "SEIZAIKEN" on its (+) side.

TECHNICAL GUIDE

SEIKO
QUARTZ

CAL. 9020A
CAL. 9021A
CAL. 9029A

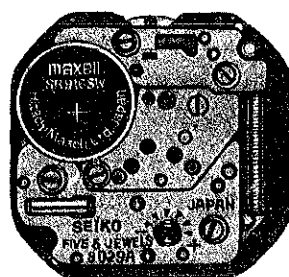

CONTENTS

I. SPECIFICATIONS	1
II. STRUCTURE OF CIRCUIT BLOCK	1
III. DISASSEMBLING, REASSEMBLING AND LUBRICATING	2
IV. CHECKING AND ADJUSTMENT	5
• Check output signal	5
• Check hand setting condition	5
• Check battery voltage	5
• Check battery conductivity	5
• Check circuit block conductivity	5
• Check coil block	5
• Check reset and train wheel setting conditions	6
• Check gear train mechanism	6
• Check setting mechanism	6
• Check accuracy	6
• Check current consumption	7
• Check water resistance	7
• Check conductivity of switch components	7
• Check appearance and functioning	7

I. SPECIFICATIONS

Item	Cal.	9020A	9021A	9029A
Time indication		2 hands	3 hands	2 hands
Additional mechanism		--		Date
		--		Instant date setting device
		Train wheel setting device		
		--	Battery life indicator	--
		Electronic circuit reset switch		
Loss/gain		Monthly rate: Less than 15 seconds		
Movement size	Outside diameter	$\phi 24.0\text{mm}$ (22.0mm between 6 o'clock and 12 o'clock sides 19.0mm between 3 o'clock and 9 o'clock sides)		$\phi 24.6\text{mm}$ (22.0mm between 6 o'clock and 12 o'clock sides 21.0mm between 3 o'clock and 9 o'clock sides)
	Casing diameter	$\phi 23.3\text{mm}$ (21.0mm between 6 o'clock and 12 o'clock sides 19.0mm between 3 o'clock and 9 o'clock sides)		
	Height	1.8mm		2.2mm
Regulation system		Rotary step switch		
Measuring gate by Quartz Tester		Use the gate of 10 seconds.		
Battery		SEIKO (SEIZAIKEN) TR916SW Maxell SR916SW Battery life is approximately 3 years.		
Jewels		5 jewels		

II. STRUCTURE OF CIRCUIT BLOCK

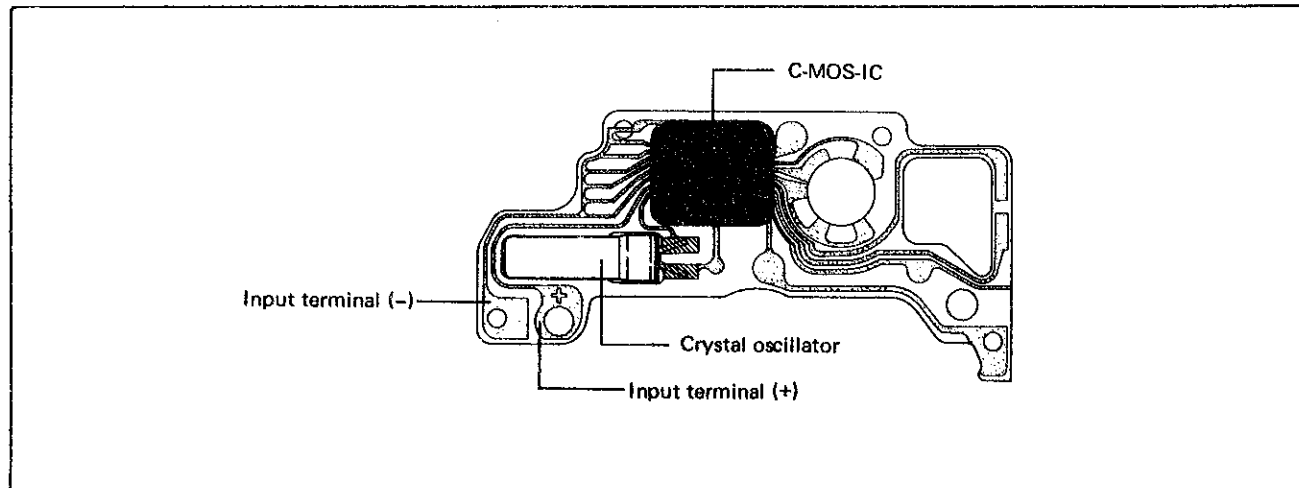



III. DISASSEMBLING, REASSEMBLING AND LUBRICATING

Types of oil

- Moebius A
- SEIKO Watch Oil S-6

List of screws used

Shape	Part No.	Part Name	Shape	Part No.	Part Name
	022436	Train wheel bridge screw (2 pcs.) Circuit bridge plate screw (2 pcs.) Setting wheel plate complete screw (2 pcs.)		022754	Date dial guard screw (3 pcs.)

Disassembling procedures ① → ④③

● Use the universal movement holder for disassembling and reassembling.

Reassembling procedures ④③ → ①

1. Hour and minute hands ~ hour wheel

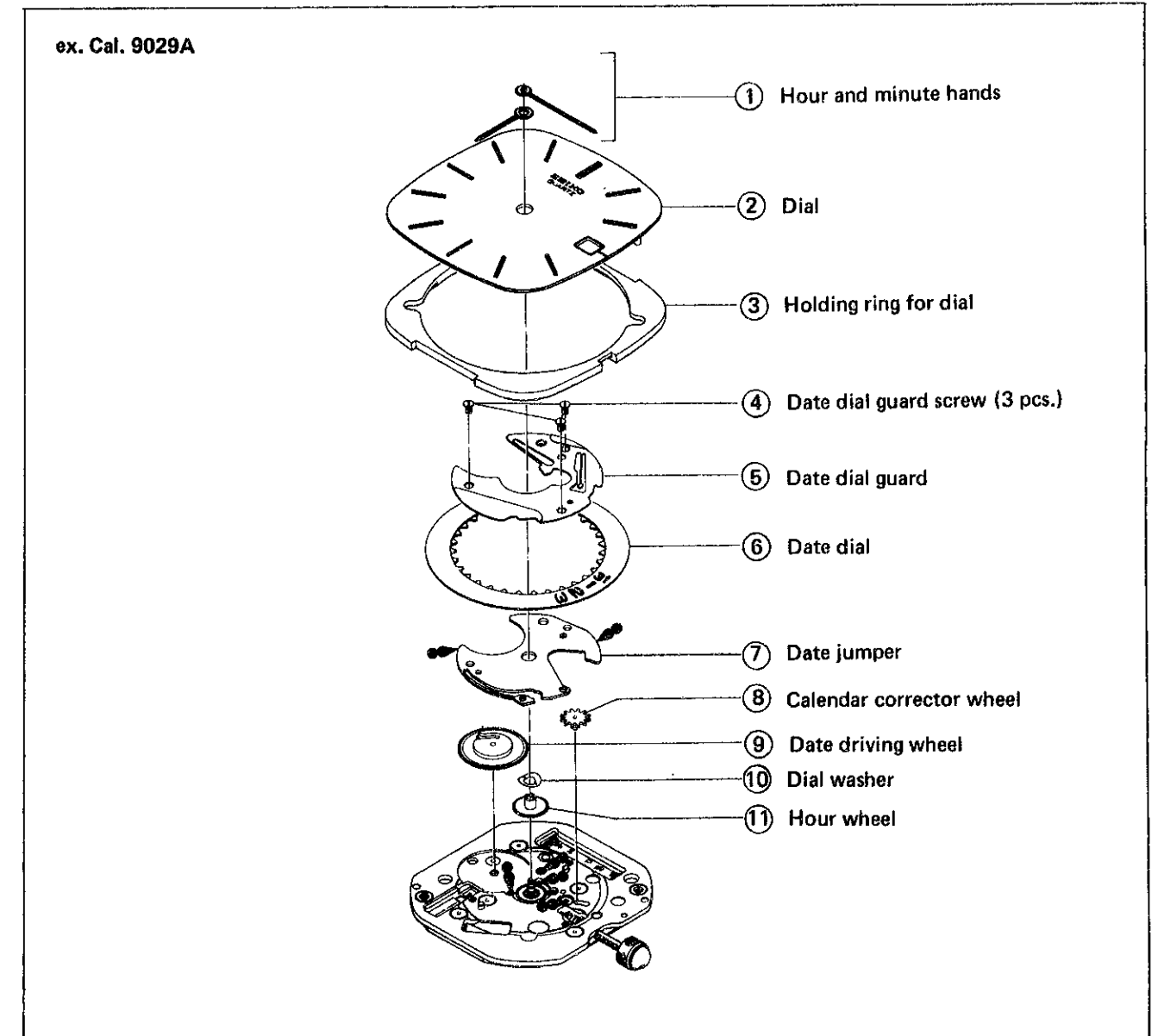

2. Circuit bridge plate screw ~ intermediate minute wheel

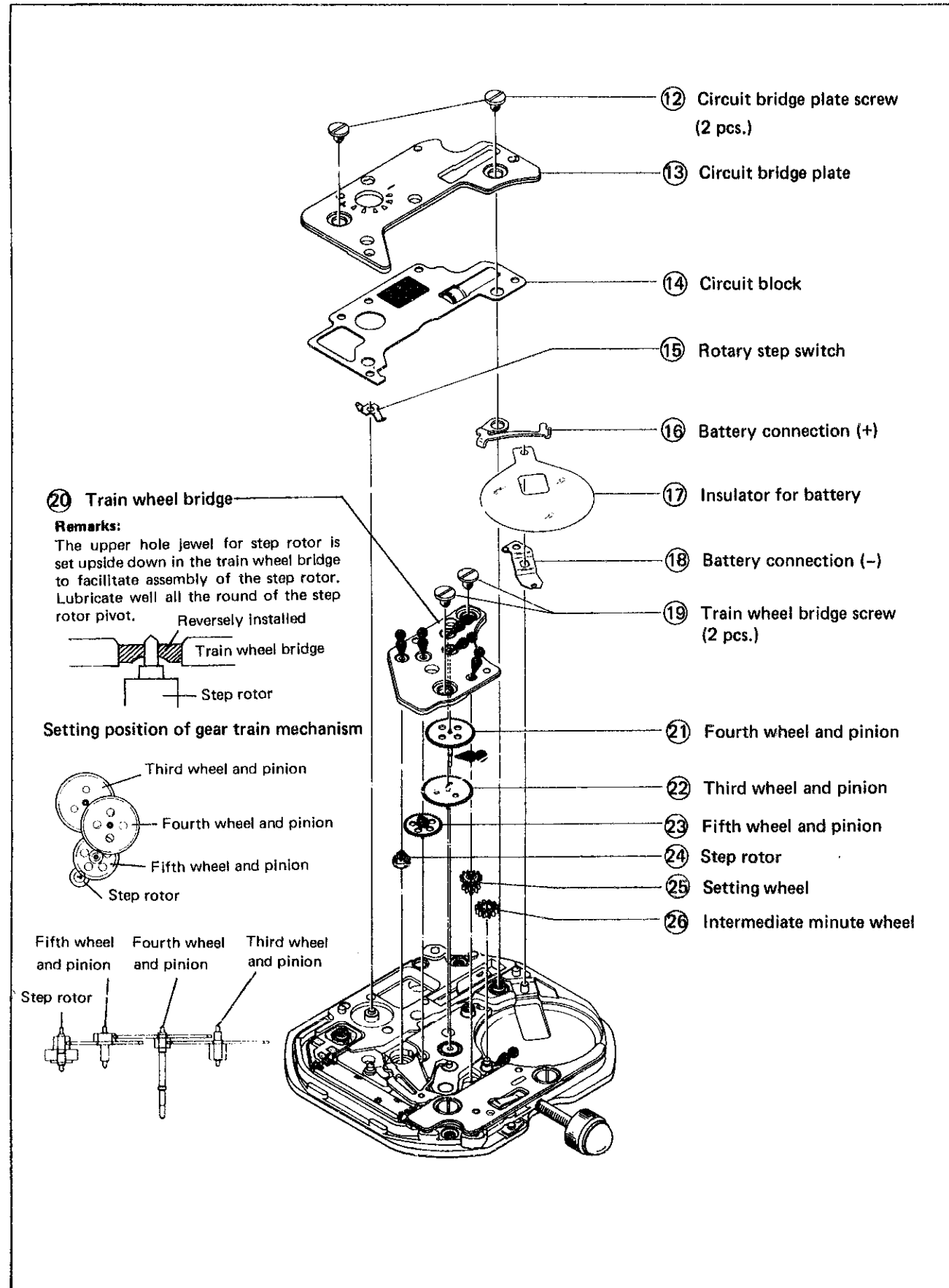

3. Setting wheel plate complete screw ~ center wheel and pinion

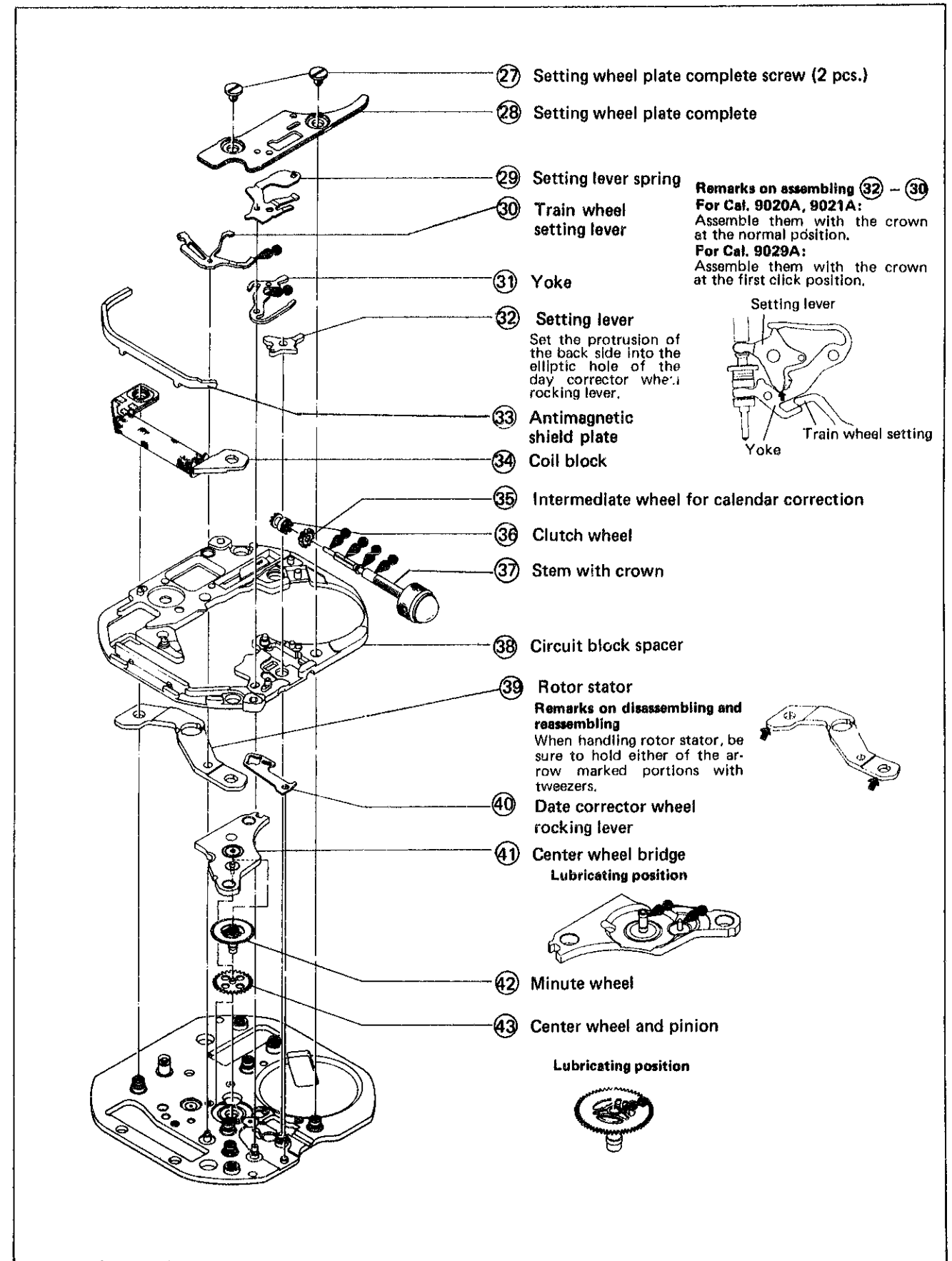

IV. CHECKING AND ADJUSTMENT

- The explanation here is only for the particular points of Cal. 9020A, 9021A and 9029A. Refer to the "TECHNICAL GUIDE, GENERAL INSTRUCTION" for SEIKO Analogue Quartz for details.

Procedure	
CHECK OUTPUT SIGNAL	<p>Use the quartz tester.</p> <p>Range to be used: 10-second gate</p> <p>Result: Normal : Input indicator blinks every 1 second. Defective: Input indicator does not blink every 1 second.</p>
CHECK HAND SETTING CONDITION	
CHECK BATTERY VOLTAGE	<p>Set up the volt-ohm-meter</p> <p>Range to be used: DC 3V</p> <p>Result: Normal : More than 1.5V Defective: Less than 1.5V</p>
CHECK BATTERY CONDUCTIVITY	
CHECK CIRCUIT BLOCK CONDUCTIVITY	
CHECK COIL BLOCK	<p>Set up the volt-ohm-meter</p> <p>Range to be used: OHMS x 100</p> <p>Result: Normal : $2.7K\Omega \sim 3.4K\Omega$ Defective: $\left\{ \begin{array}{l} \text{Less than } 2.7K\Omega \\ \text{(Short circuit)} \\ \text{More than } 3.4K\Omega \\ \text{(Broken wire)} \end{array} \right.$</p>

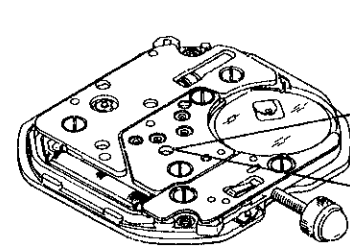
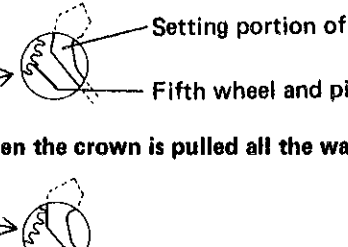
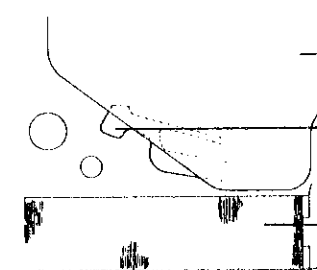
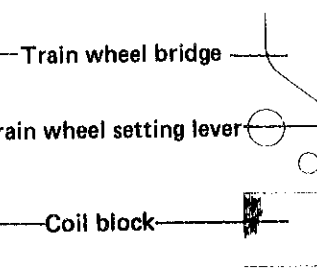
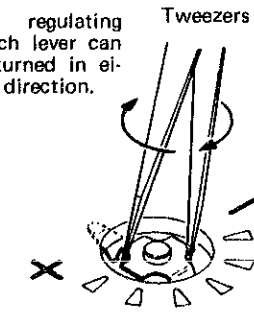
Procedure
CHECK RESET AND TRAIN WHEEL SETTING CONDITIONS
<ol style="list-style-type: none"> Check to see if the step rotor stops promptly when the crown is pulled all the way out and if it starts 1 second after the crown is pushed back to the normal position by using a microscope. Check the clearance between train wheel setting lever and fifth wheel and pinion by looking through the hole of train wheel bridge. <div style="display: flex; justify-content: space-around; align-items: center;"> <div style="text-align: center;"> <p>When the crown is pushed back to the normal position.</p>  </div> <div style="text-align: center;"> <p>When the crown is pulled all the way out.</p>  </div> </div> Check the position of train wheel setting lever after disassembling the circuit block. <div style="display: flex; justify-content: space-around; align-items: center;"> <div style="text-align: center;"> <p>When the crown is pushed back to the normal position.</p>  </div> <div style="text-align: center;"> <p>When the crown is pulled all the way out.</p>  </div> </div>
CHECK GEAR TRAIN MECHANISM
CHECK SETTING MECHANISM
CHECK ACCURACY
<p>Measuring time accuracy</p> <ul style="list-style-type: none"> Use the 10-second gate of the quartz tester. Be sure to protect the C-MOS-IC from light with case back or black paper, etc. while measuring. Do not measure accuracy under an incandescent lamp, since strong light adversely affects time accuracy. <p>Adjusting time accuracy</p> <ul style="list-style-type: none"> When adjusting time accuracy, turn the rotary step switch by tweezers and correspond either end of rotary step switch with a mark on circuit bridge plate. The range to be regulated by the regulating switch lever is ± 0.26 sec./day. <div style="text-align: right;"> <p>The regulating switch lever can be turned in either direction.</p>  </div>

Procedure

CHECK CURRENT CONSUMPTION

- Be sure to protect the C-MOS-IC from light with black paper, etc. while measuring.
Do not check current consumption under an incandescent lamp, since strong light causes a watch to consume excess current.

Set up the volt-ohm-meter

Range to be used: DC 12 μ A

Result:

Normal : Less than 0.9 μ A

Defective: More than 0.9 μ A

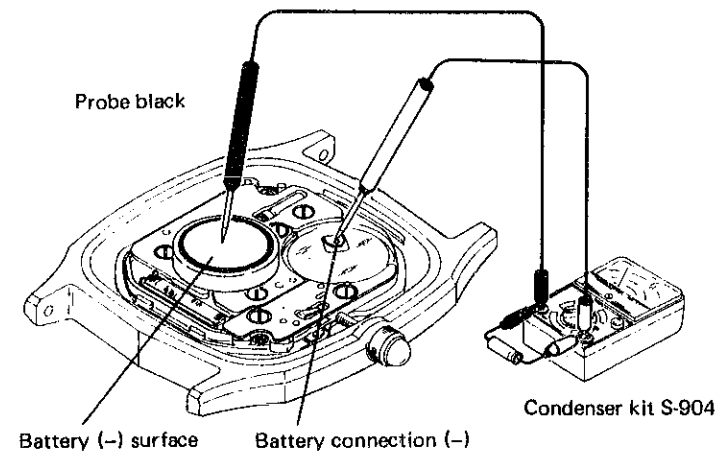

CHECK WATER RESISTANCE

CHECK CONDUCTIVITY OF SWITCH COMPONENTS

CHECK APPEARANCE AND FUNCTIONING

All procedures of Disassembling, Reassembling, Lubricating, Checking and Adjustment are completed.