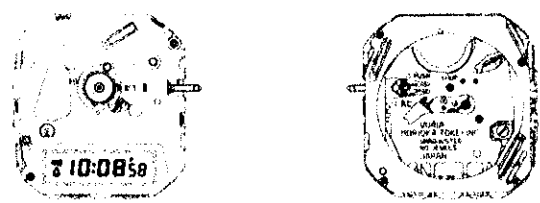

SERVICE GUIDE CAL. V041A

1. SPECIFICATIONS

Item		Cal. No.	V041A	
Movement				
Movement size	Outside diameter	24.5mm between 6 o'clock and 12 o'clock sides 23.0mm between 3 o'clock and 9 o'clock sides		
	Casing diameter	—		
	Height	3.9mm		
Display	Analogue display	Digital display		
Time indication	Three hands	Nematic Liquid Crystal, FEM (Field Effect Mode)		
Driving system	Step motor (Load compensated driving pulse type)	Multiplex driving system		
Additional mechanism	Electronic circuit reset switch	Hourly time signal Alarm test system		
Loss/gain	Monthly rate: Less than 30 seconds at normal temperature range			
Regulation system	Nil			
Measuring gate by quartz tester	Use 10-second gate.			
Battery	SEIKO SR726W, MAXELL SR726W, SONY SR726W Voltage: 1.55V Battery life is approximately 2 years.			
Jewels	0 jewel			

2. REMARKS ON AFTER-SALES SERVICING

- Movement parts are fixed by heat-treatment. If the movement is found to be out of order, therefore, replace the whole movement with a new one.
- Among the movement parts, only the following are available for supply.
 - Piezoelectric element 4589 013
 - Winding stem* 354 118

*The type of winding stem is determined by the design of case. Check the case number and refer to "Casing Parts Catalogue" to choose a corresponding one.

3. NOTES ON REPLACING THE MOVEMENT

(1) How to remove the winding stem

- While pushing the indented portion of the switch spring as shown in the illustration below, pull out the winding stem.
- Do not lubricate the winding stem. If it is stained with oil during assembling or disassembling procedures, wipe it off thoroughly with nylon cloth. If the oilstained winding stem is installed on the movement, the clutch wheel will slip out of engagement with the winding stem, and thus hand-setting will be made impossible.

Indented portion of the switch spring

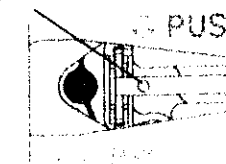

(2) How to install the hands

Since a plastic train wheel bridge is used, place the movement directly on a flat metal plate or the like, and follow the procedures below to install the hands.

- First set the winding stem and dial on the movement, and then install the battery. Set the winding stem with crown at the normal position (pushed-in position), and check that the watch is operating.
- With the watch operating, remove the battery when the hole of the train wheel bridge and one of the three holes of the third wheel and pinion completely overlap with each other, having a common center.

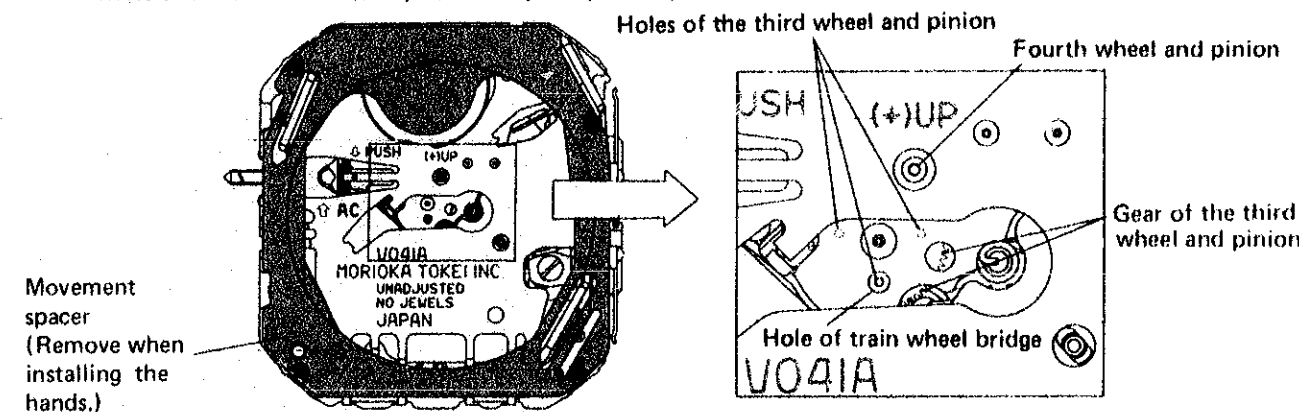

- Be sure to install the hour, minute and second hands so that they point exactly to the 12 o'clock position. *Never operate the winding stem with crown while installing the hands. Otherwise, the train wheel bridge and the third wheel and pinion will get out of the position where they were set in Step. 2.

Flat metal plate (stainless steel plate, etc.)

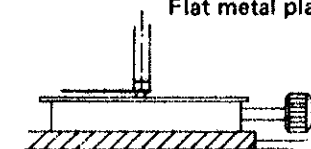

- After installing the hands, check again that the hole of the train wheel bridge and the hole of the third wheel and pinion have a common center. If otherwise, repeat the procedures again from the beginning.

4. A NECESSARY STEP AFTER INSTALLING THE BATTERY

After the battery is replaced with a new one, or after the battery is removed and reset in replacing the movement, be sure to short the AC terminal of the circuit block and the switch spring with conductive tweezers to reset the circuit.

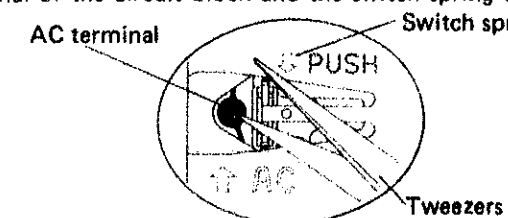

5. VALUE CHECKING

- Current consumption

Use the SEIKO Digital Multi Tester (with Multi-Adaptor)

For the whole movement Less than 2.0μA