

TECHNICAL GUIDE AND PARTS LIST

CAL. V3 SERIES

ANALOGUE QUARTZ

CONTENTS

I. FOREWORD	1
II. SPECIFICATIONS	2
III. LIST OF SCREWS USED.....	2
IV. DISASSEMBLING, REASSEMBLING AND LUBRICATING	3
1. Calendar mechanism.....	3
2.-a Circuit block · Drive Coil · Gear train/Selector mechanism (except V300, V320).....	4
2.-b Circuit block · Drive Coil · Gear train/Selector mechanism (V300, V320 only).....	5
V. CLEANING.....	6
1. How to clean.....	6
2. Parts that must not be cleaned.....	6
VI. CHECKING AND ADJUSTMENT	7
1. Structure of circuit block.....	7
2. Procedures for checking and adjustment.....	7
● BATTERY VOLTAGE	7
● COIL BLOCK	7
● ACCURACY	7
● RESET CONDITION	8
● CURRENT CONSUMPTION.....	8
VII. PARTS LIST.....	9 - 16

I. FOREWORD

Compared with the former analogue watch, the Cal. V3 series employs many engineering plastic parts. The engineering plastic parts used in this watch has the superb solvent proof and heat resistance performance, compared with the plastic parts (main plate, train wheel bridge, etc.) used in the former analogue watch. However, compared with the watch using metal parts, pay attention to the parts handling, especially for cleaning. For details, refer to the appropriate section of this Technical Guide.

II. SPECIFICATIONS

Item	Cal. No.	V300	V301	V312	V313	V320	V321	V322	V329	V332	V333	V342	V343	V347	V348	
Indication system		Two Hands	Three Hands	←	←	Two Hands	Three Hands	←	Two Hands	Three Hands	←	←	←	←	←	
Additional mechanism		-	-	-	Day	-	-	-	-	-	Day	-	Day	-	Day	
		-	-	Date	Date	-	-	Date	Date	Date	Date	Date	Date	Date	Date	
		-	-	Date quick resetting device	Day/date quick resetting device	-	-	Date quick resetting device	Date quick resetting device	Date quick resetting device	Day/date quick resetting device	Date quick resetting device	Day/date quick resetting device	Date quick resetting device	Day/date quick resetting device	
		-	Second setting device (Stops at every second)				-	Second setting device (Stops at every second)								
		-	Electronic reset switch				-	Electronic reset switch								
Loss/gain		Monthly rate: less than 20 seconds at normal temperature range														
Movement size	Size of main plate	φ15.3x18.2	←	(3-9H) φ20.0x18.0	←	(3-9H) φ24.0x19.2x21.5	←	←	←	(3-9H) φ24.0x21.3x21.5	←	(3-9H) φ26.4x23.5x23.5	←	←	←	
	Casing diameter	φ15.3x17.8	←	φ19.4x18.0	←	φ23.3x19.2x21.5	←	←	←	φ23.3x21.3x21.5	←	φ25.6x21.9x23.5	←	←	←	
	Height	2.1	2.3	2.6	2.9	2.1	2.1	2.6	2.6	2.6	2.9	2.6	2.9	3.0	3.3	
Regulation system		None														
Quartz tester measuring gate		10-second gate														
Battery life		3	2	2	2	3	3	3	3	3	3	3	3	5	5	
Battery		MAXELL SR616SW	MAXELL SR621SW	-	-	MAXELL SR616SW	MAXELL SR916SW	MAXELL SR916SW	MAXELL SR916SW	MAXELL SR916SW	MAXELL SR916SW	MAXELL SR916SW	MAXELL SR916SW	MAXELL SR920SW	MAXELL SR920SW	
		-	U.C.C. 364	-	-	-	-	-	-	-	-	-	-	-	-	
		-	SONY EVEREADY 364	-	-	-	-	-	-	-	-	-	-	SONY EVEREADY 371	SONY EVEREADY 371	
		SEIKO TR616SW	SEIKO TR621SW	-	-	SEIKO TR616SW	SEIKO TR916SW	SEIKO TR916SW	SEIKO TR916SW	SEIKO TR916SW	SEIKO TR916SW	SEIKO TR916SW	SEIKO TR916SW	SEIKO TR916SW	SEIKO SR920SW	SEIKO SR920SW
		-	-	MATSUSHITA SR716SW	MATSUSHITA SR716SW	-	MATSUSHITA SR916SW	MATSUSHITA SR916SW	MATSUSHITA SR916SW	MATSUSHITA SR916SW	MATSUSHITA SR916SW	MATSUSHITA SR916SW	MATSUSHITA SR916SW	MATSUSHITA SR916SW	-	-
Jewels		0	1	1	1	0	1	1	1	1	1	1	1	1	1	

III. LIST OF SCREWS USED

Two types of screws are used in Cal. V3 series. When servicing the watch, refer to the table below.

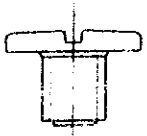
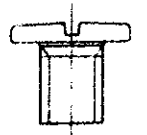
Type	Parts No.	Parts Name	Difference (Screw head dia.)
	022 410	Train wheel bridge screw 1 pce. Coil block screw 1 pce. Battery connection (+) screw 3 pcs.	Large (φ1.5 mm)
	022 248	Date dial guard screw 2 pcs.	Small (φ1.3 mm)

IV. DISASSEMBLING, REASSEMBLING AND LUBRICATING

Disassembling procedures: Figs ① ~ ⑭
 Reassembling procedures: Figs ⑭ ~ ①

1. Calendar mechanism

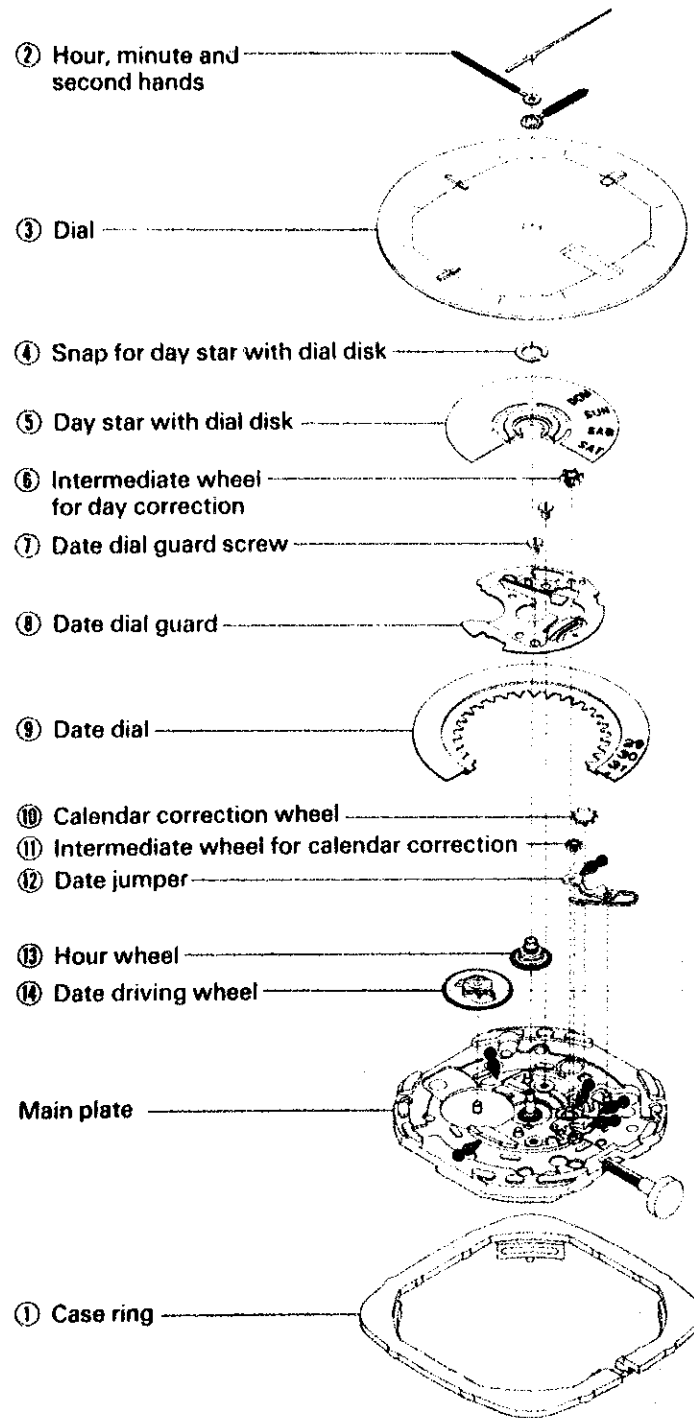

Note: Disassembling/reassembling the dial

The dial is mounted with its two legs inserted into the dial leg holes in main plate, providing some interference. To remove the dial, carefully pry out the dial with a screwdriver inserted into the gap in 2 and 8 o'clock position.

● Lubricating: ● Moebius A

Notes on fitting the hands

● When fitting the hands, remove the battery and support the whole surface of the train wheel bridge with a flat solid material (stainless steel, etc.), then press in the hands. Never use a universal movement holder, because it cannot support the surface of the train wheel bridge.

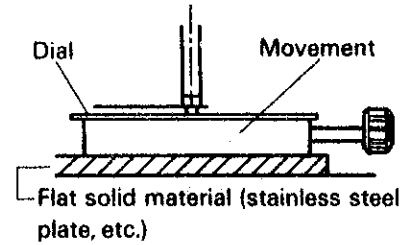

Note: Assemble the calendar correction mechanism as shown below.

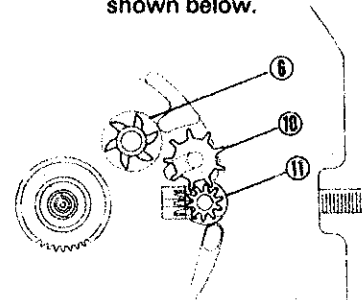

Especially, pay attention to the mounting direction of the intermediate wheel for day correction ⑩ and Calendar correction wheel ⑪. (The intermediate wheel for calendar correction ⑪ can be mounted in any direction.)

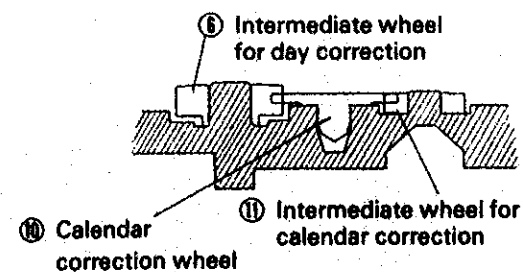

2.-a. Circuit block · Drive Coil · Gear train/Selector mechanism (For Cal. V300, Cal. V320, see the next page)

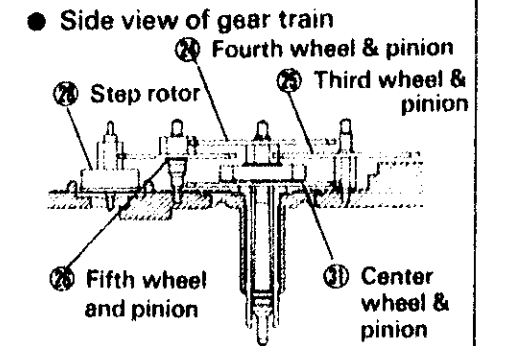
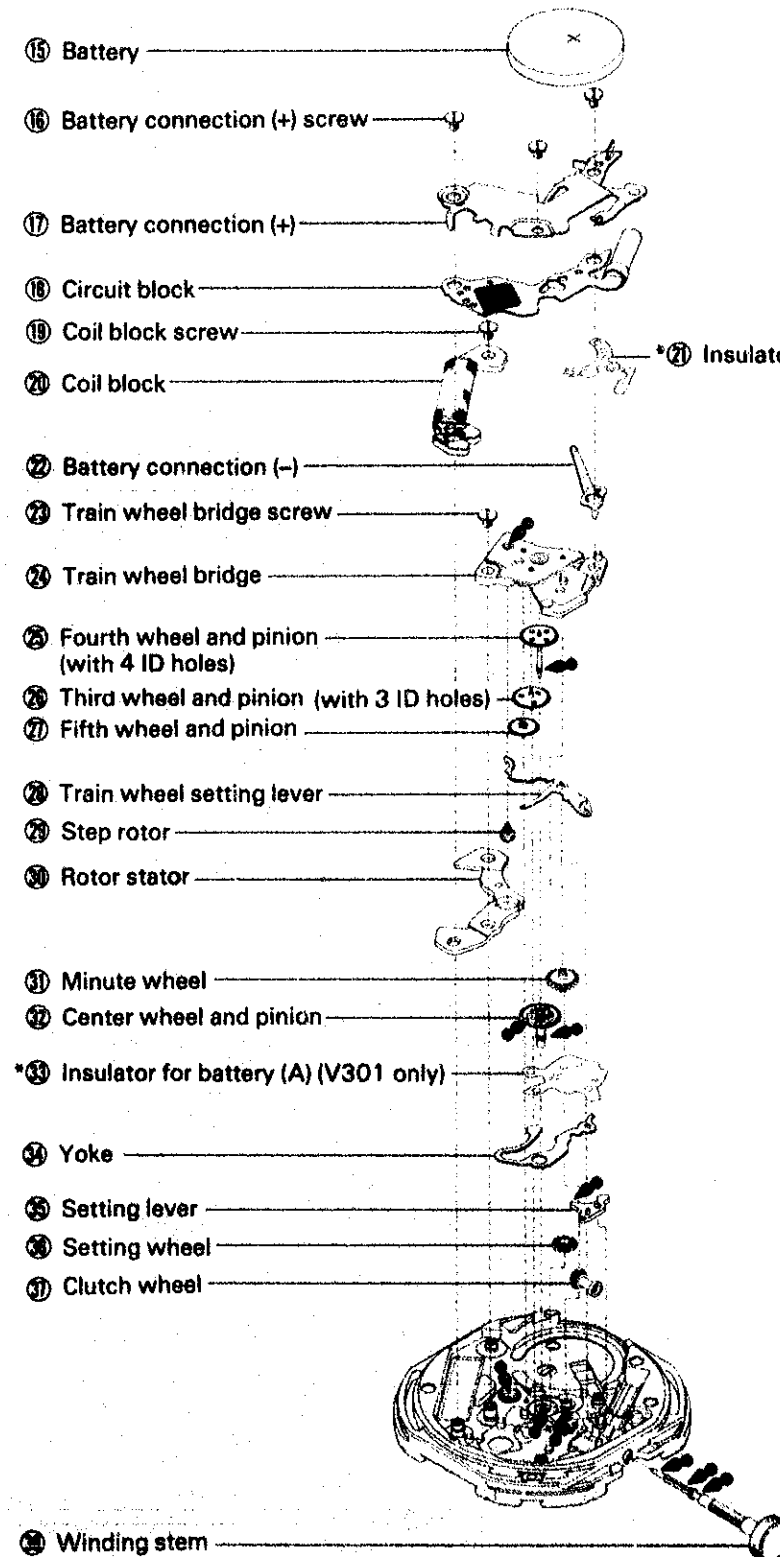

Note: In Cal. V301, *insulators for battery (A) ⑬ and (B) ⑰ are installed. In the other models, (V3 series), they are not used.

Note: Install the train wheel setting lever as shown below.

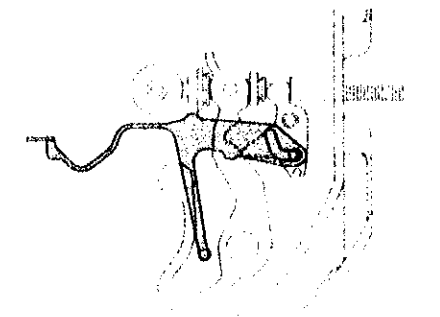

Note: Handling the step rotor
 Be sure to hold the cam or magnet part of the step rotor.

Note: HOW TO REMOVE THE WINDING STEM

To remove the winding stem, press the portion indicated with PUSH ⇨ in the below figure with the crown set to the normal position.

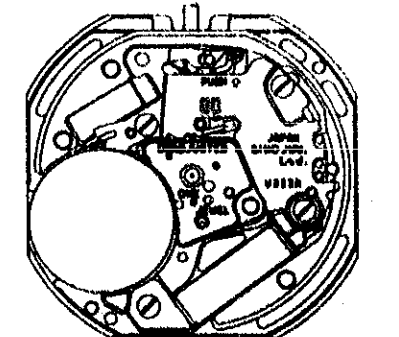

**2.-b. Circuit block · Drive Coil · Gear train/Selector mechanism
(Cal. V300, Cal. V320 only)**

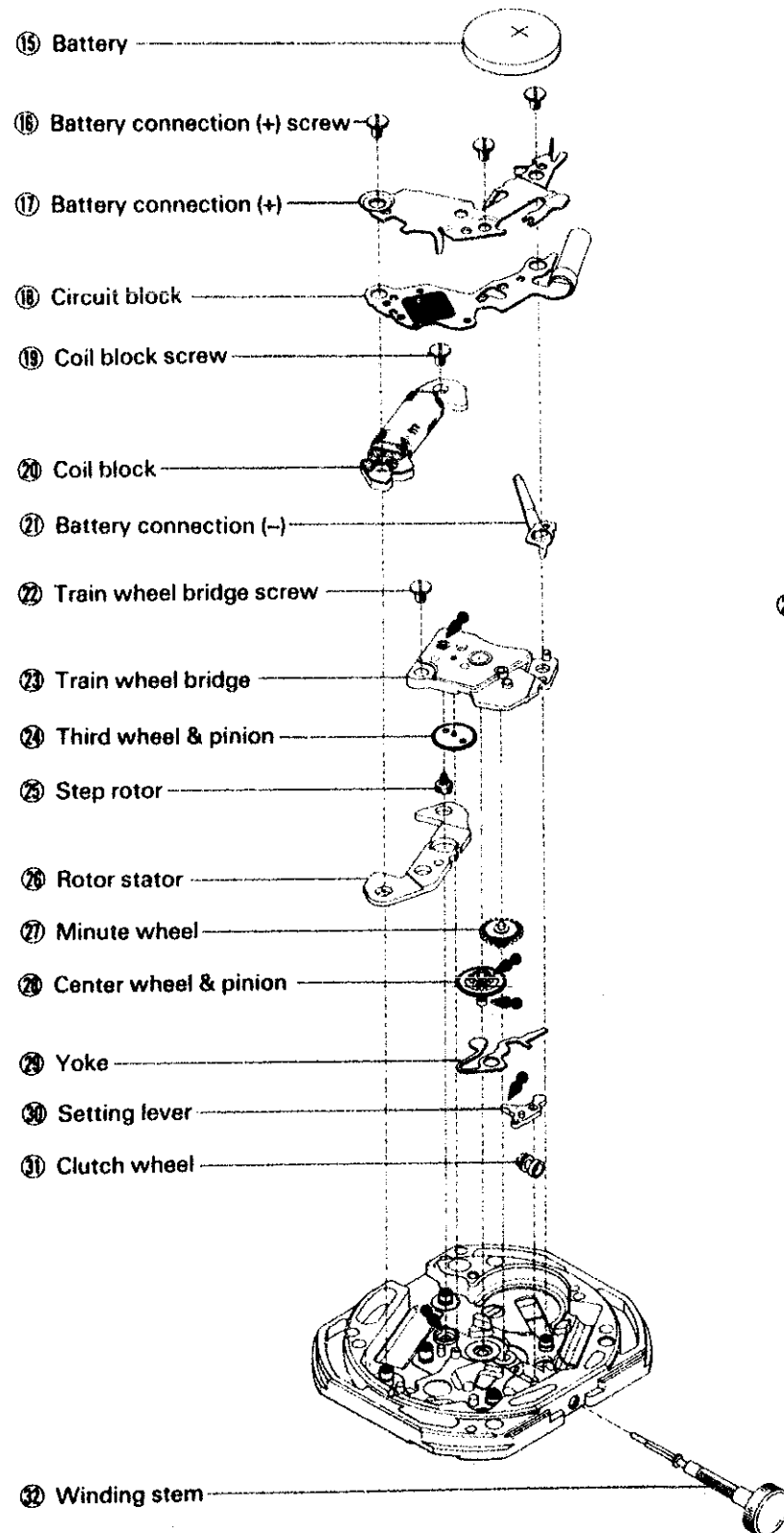

Note: Gear train mechanism in Cal. V300 and Cal. V320 differs from that in other models (V3 series).

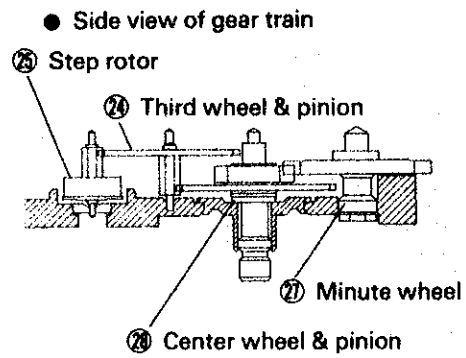

Note: HOW TO REMOVE THE WINDING STEM
To remove the winding stem, press the portion indicated with PUSH ⇒ in the below figure with the crown set to the normal position.

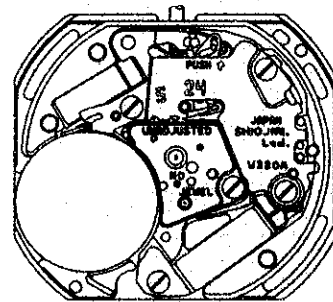

«Lubrication list»

Date dial guard	● Tip of the day jumper	Center wheel and pinion	Fourth wheel and pinion
Main plate	● Sliding part of date dial (3 portions) ● Rear surface of calendar correction wheel ● Setting wheel shaft ● Step rotor shaft hole ● Intermediate wheel for day correction shaft		
Setting lever	● Contact portion with yoke		
Winding stem	● Whole surface		
Train wheel bridge	● Step rotor shaft hole		

V. CLEANING

● The Cal. V3 series employs many plastic parts. Carefully clean the parts referring to the table below.

(1) How to clean

Name of parts	Cleaning	Drying	Solution	Remarks
● Plastic parts (main plate, train wheel bridge)	● Rinse or scrub with a soft brush.	● Warm air drying	● Benzine ● DIFLON S-3 ● Alcohol	● Use Rodico to wipe off the hard contamination. ● Clean with benzine for a short time.
● Other parts (excluding parts that must not be cleaned.)	● Clean with a cleaner, rinse or gently scrub with a soft brush.	● Warm or hot air drying	● Benzine ● DIFLON S-3 ● Alcohol ● Trichloroethylene	● As the step rotor is a magnetic parts, clean with a pure solution.

(2) Parts that must not be cleaned

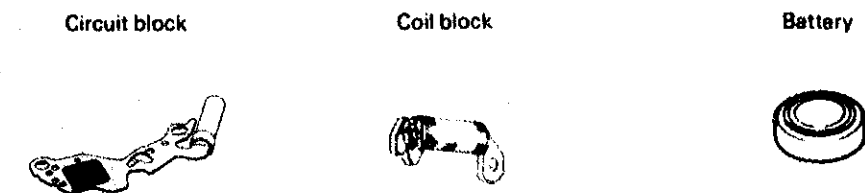

● Be sure to clean only stains on the conductive portions of the circuit block, etc. with a cloth moistened with benzine, DIFLON S-3 or alcohol and dry them with warm air.

VI. CHECKING AND ADJUSTMENT

1. Structure of circuit block

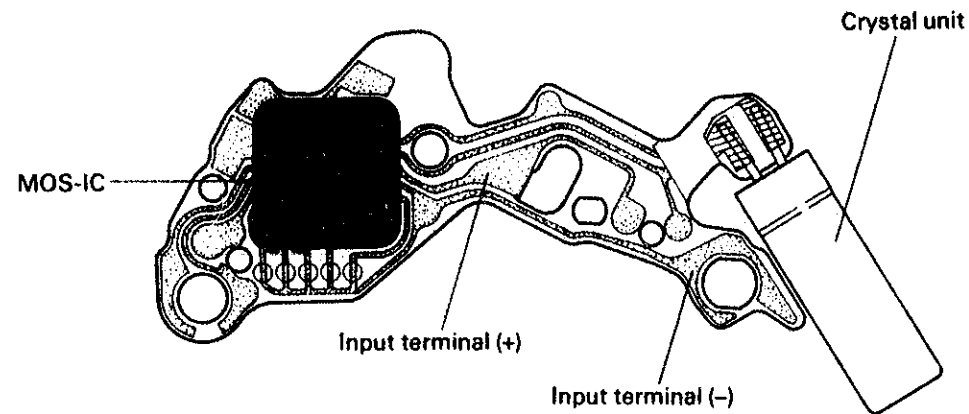

2. Procedures for checking and adjustment

- This section only gives the checking and adjustment procedures which is exclusive for Cal. V3 series. For the normal checking and adjustment, refer to the "TECHNICAL GUIDE GENERAL INSTRUCTION, Analogue Quartz".

BATTERY VOLTAGE	
Use the Digital Multi Tester S-840A Range to be used: DC V Note: Before measuring, short circuit the probes and confirm the tester reads AUTO 00.0 mV or AUTO 00.1 mV.	Result: More than 1.5V: Normal Less than 1.5V: Defective Replace the battery.
COIL BLOCK	
Check the coil block for broken wire and short circuit using the Digital Multi Tester-840A Range to be used: Ω Notes: <ul style="list-style-type: none"> ● Before measuring, short circuit the probes and check to see if the tester sounds and reads from AUTO 00.2Ω to AUTO 00.4Ω. The actual resistance can be obtained by subtracting the initial value (00.2 - 00.4) from the measured value. ● When measuring, take care not to break the coil block leads. 	<ul style="list-style-type: none"> ● Cal. V3 series (except V300, V320) 3.0 ~ 3.4 kΩ: Normal More than 3.4 kΩ (broken wire): Defective Less than 3.0 kΩ (short circuit): Defective Replace the coil block. ● Cal. V300, V320 1.5 ~ 1.9 kΩ: Normal More than 1.9 kΩ (broken wire): Defective Less than 1.5 kΩ (short circuit): Defective Replace the coil block.
ACCURACY	
Check accuracy using Quartz Tester (10-second gate) and an electromagnetic microphone (DM-1). Note: Check accuracy with the crown at normal position.	Result: Monthly rate (at normal temperature range) Less than 20 seconds: Normal More than 20 seconds: Defective Replace the circuit block

RESET CONDITION

- (1) When the crown is fully pulled, the second hand should be stopped completely. When the crown is set to the normal position, the second hand should start moving after 1 second.
- (2) Check the condition of the train wheel setting lever viewing through the hole in the train wheel bridge near the coil block as shown in the figure.

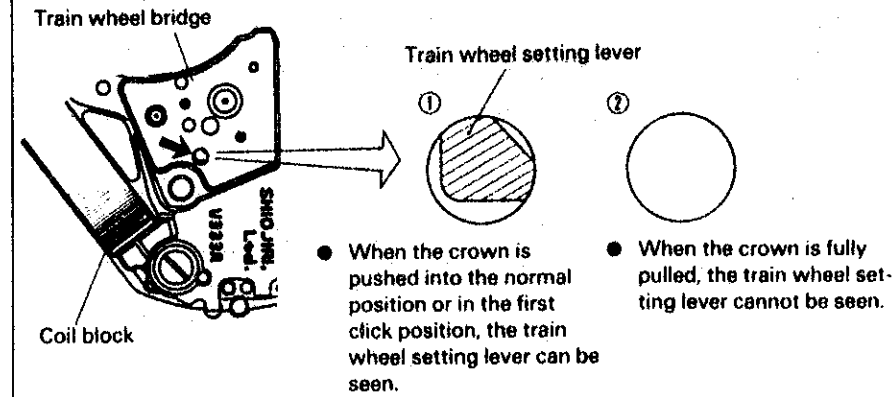

Result:
 Moves after 1 second: Normal
 Does not stop: Defective
 Proceed to (2)

{ Correct (figure ①, ②): Normal
 Fault: Defective
 Replace the train wheel setting lever.

- (3) When the crown is fully pulled, check the output signal of the Quartz Tester.

Result:
 No output signal: Normal
 Output signal: Defective
 Replace the circuit block.

CURRENT CONSUMPTION

Use the Digital Multi Tester S-840A
 Range to be used: μA

Red probe: Battery connection (-)
 Black probe: Battery (+)

Current Consumption

As shown in the figure below, place the battery with its (-) surface upward on the battery connection (+), confirming that the battery connection (+) contacts with the (+) surface of the battery, before performing measurement.

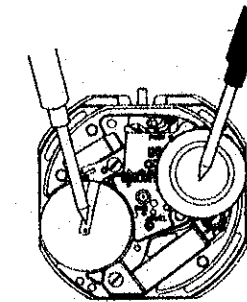

Note:

The battery connection (-) has the following construction to come into contact with battery. When checking the current consumption, be sure to press in the battery connection (-) with the probe.

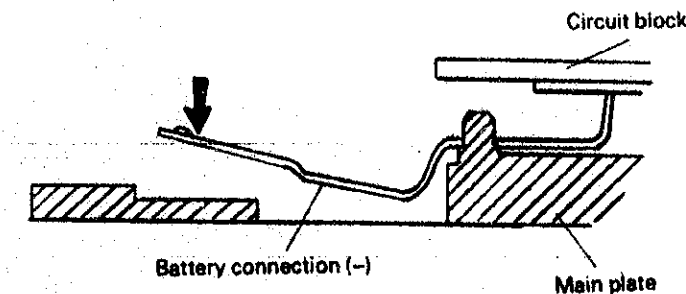

Result:

- Cal. V3 series (Except cal. V300, V320)
 Less than 1.2 μA : Normal
 More than 1.2 μA : Defective
 Replace the circuit block
- Cal. V300, V320
 Less than 0.5 μA : Normal
 More than 0.5 μA : Defective
 Replace the circuit block

VII. PARTS LIST

CAL. V300 A		CAL. V320 A	
PARTS NO.	PARTS NAME	PARTS NO.	PARTS NAME
125 532	Train wheel bridge	125 532	Train wheel bridge
• 221 525	Center wheel & pinion	• 221 525	Center wheel & pinion
• 221 526	Center wheel & pinion	• 221 526	Center wheel & pinion
• 221 527	Center wheel & pinion	• 221 527	Center wheel & pinion
• 221 528	Center wheel & pinion	• 221 528	Center wheel & pinion
231 526	Third wheel & pinion	231 526	Third wheel & pinion
261 531	Minute wheel	261 531	Minute wheel
• 271 525	Hour wheel	• 271 525	Hour wheel
• 271 526	Hour wheel	• 271 526	Hour wheel
• 271 527	Hour wheel	• 271 527	Hour wheel
• 271 528	Hour wheel	• 271 528	Hour wheel
282 532	Clutch wheel	282 532	Clutch wheel
• 354 532	Winding stem	• 354 532	Winding stem
383 530	Setting lever	383 530	Setting lever
384 531	Yoke	384 531	Yoke
491 220	Dial washer	491 220	Dial washer
4001 749	Circuit block	4001 749	Circuit block
4002 533	Coil block	4002 533	Coil block
4146 533	Step rotor	4146 533	Step rotor
4239 533	Rotor stator	4239 533	Rotor stator
4270 531	Battery connection (-)	4270 531	Battery connection (-)
4271 673	Battery connection (+)	4271 667	Battery connection (+)
390 530	Setting lever pin	390 530	Setting lever pin
022 410	Train wheel bridge screw	022 410	Train wheel bridge screw
022 410	Coil block screw	022 410	Coil block screw
022 410	Battery connection (+) screw	022 410	Battery connection (+) screw
• SEIKO TR616SW } • MAXELL SR616SW }	Battery	• SEIKO TR616SW } • MAXELL SR616SW }	Battery

Remarks:

- *Winding stem

The type of winding stem is determined based on the design of case. Check the case number and refer to "Casing Parts Catalogue" to choose a corresponding winding stem.

- *Center wheel & pinion, Hour wheel

There are four different types as specified below.

Combination:

*Type	Center wheel & pinion	Hour wheel
SS	221 525	271 525
S	221 526	271 526
M	221 527	271 527
L	221 528	271 528

* Abbreviation (Movement type)
 SS..... Extra short type
 S..... Short type
 M..... Standard type
 L..... Long type

CAL. V321 A	
PARTS NO.	PARTS NAME
125 530	Train wheel bridge
• 221 531	Center wheel & pinion
• 221 532	Center wheel & pinion
• 221 534	Center wheel & pinion
231 530	Third wheel & pinion
• 241 531	Fourth wheel & pinion
• 241 532	Fourth wheel & pinion
• 241 534	Fourth wheel & pinion
261 530	Minute wheel
• 271 531	Hour wheel
• 271 532	Hour wheel
• 271 534	Hour wheel
281 530	Setting wheel
282 531	Clutch wheel
• 354 530	Winding stem
383 530	Setting lever
384 530	Yoke
391 530	Train wheel setting lever
491 220	Dial washer
701 530	Fifth wheel & pinion
4001 748	Circuit block
4002 532	Coil block
4146 531	Step rotor
4239 534	Rotor stator
4270 531	Battery connection (-)
4271 553	Battery connection (+)
390 530	Setting lever pin
022 410	Train wheel bridge screw
022 410	Coil block screw
022 410	Battery connection (+) screw
• SEIKO TR916SW } • MAXELL SR916SW } • MATSUSHITA SR916SW }	Battery

Remarks:

- *Winding stem

The type of winding stem is determined based on the design of case. Check the case number and refer to "Casing Parts Catalogue" to choose a corresponding winding stem.

- *Center wheel & pinion, Fourth wheel & pinion, Hour wheel

There are three different types as specified below.

Combination:

*Type	Center wheel & pinion	Fourth wheel & pinion	Hour wheel
S	221 531	241 531	271 531
M	221 532	241 532	271 532
L	221 534	241 534	271 534

*Abbreviation (Movement type)
 S..... Short type
 M..... Standard type
 L..... Long type

CAL. V322 A			
PARTS NO.	PARTS NAME	PARTS NO.	PARTS NAME
125 530	Train wheel bridge	802 531	Date driving wheel
* 221 533	Center wheel & pinion	808 531	Date dial guard
* 221 535	Center wheel & pinion	810 530	Date jumper
* 221 538	Center wheel & pinion	962 531	Intermediate wheel for calendar correction
231 530	Third wheel & pinion		
* 241 533	Fourth wheel & pinion	4001 748	Circuit block
* 241 534	Fourth wheel & pinion	4002 532	Coil block
* 241 536	Fourth wheel & pinion	4146 531	Step rotor
261 530	Minute wheel	4239 534	Rotor stator
* 271 533	Hour wheel	4270 531	Battery connection (-)
* 271 534	Hour wheel	4271 543	Battery connection (+)
* 271 535	Hour wheel	390 530	Setting lever pin
281 530	Setting wheel	022 248	Date dial guard screw
282 530	Clutch wheel	022 410	Train wheel bridge screw
* 354 530	Winding stem	022 410	Coil block screw
383 530	Setting lever	022 410	Battery connection (+) screw
384 530	Yoke		
391 530	Train wheel setting lever	● SEIKO TR916SW	} Battery
701 530	Fifth wheel & pinion	● MAXELL SR916SW	
737 530	Calendar correction wheel	● MATSUSHITA SR916SW	
* 801 676	Date dial		

Remarks:

* Winding stem

The type of winding stem is determined based on the design of case. Check the case number and refer to "Casing Parts Catalogue" to choose a corresponding winding stem.

* Center wheel & pinion, Fourth wheel & pinion, Hour wheel

There are three different types as specified below.

Combination:

*Type	Center wheel & pinion	Fourth wheel & pinion	Hour wheel
S	221 533	241 533	271 533
M	221 535	241 534	271 534
L	221 538	241 536	271 535

*Abbreviation S..... Short type
(Movement type) M.....Standard type
L..... Long type

* Date dial

Parts No.	Crown position	Calendar frame position	Specification
801 675	3 o'clock	3 o'clock	Black figures on gold background
801 676	3 o'clock	3 o'clock	Black figures on silver background
801 681	3 o'clock	3 o'clock	White figures on black background
801 709	3 o'clock	6 o'clock	Black figures on gold background
801 711	3 o'clock	6 o'clock	Black figures on silver background
801 712	3 o'clock	6 o'clock	white figures on black background

If any other type of date dial is required, specify ① Cal. No. ② The crown position ③ The calendar frame position and ④ Dial No.

CAL. V342 A			
PARTS NO.	PARTS NAME	PARTS NO.	PARTS NAME
125 530	Train wheel bridge	802 531	Date driving wheel
* 221 533	Center wheel & pinion	808 531	Date dial guard
* 221 535	Center wheel & pinion	810 530	Date jumper
* 221 538	Center wheel & pinion	962 531	Intermediate wheel for calendar correction
231 530	Third wheel & pinion		
* 241 533	Fourth wheel & pinion	4001 748	Circuit block
* 241 534	Fourth wheel & pinion	4002 531	Coil block
* 241 536	Fourth wheel & pinion	4146 531	Step rotor
261 530	Minute wheel	4239 530	Rotor stator
* 271 533	Hour wheel	4270 531	Battery connection (-)
* 271 534	Hour wheel	4271 547	Battery connection (+)
* 271 535	Hour wheel	390 530	Setting lever pin
281 530	Setting wheel	022 248	Date dial guard screw
282 530	Clutch wheel	022 410	Train wheel bridge screw
* 354 530	Winding stem	022 410	Coil block screw
383 530	Setting lever	022 410	Battery connection (+) screw
384 530	Yoke		
391 530	Train wheel setting lever	● SEIKO TR916SW	} Battery
701 530	Fifth wheel & pinion	● MAXELL SR916SW	
737 530	Calendar correction wheel	● MATSUSHITA SR916SW	
* 801 678	Date dial		

Remarks:

* Winding stem

The type of winding stem is determined based on the design of case. Check the case number and refer to "Casing Parts Catalogue" to choose a corresponding winding stem.

* Center wheel & pinion, Fourth wheel & pinion, Hour wheel

There are three different types as specified below.

Combination:

Type	Center wheel & pinion	Fourth wheel & pinion	Hour wheel
S	221 533	241 533	271 533
M	221 535	241 534	271 534
L	221 538	241 536	271 535

*Abbreviation S..... Short type
(Movement type) M.....Standard type
L..... Long type

* Date dial

Parts No.	Crown position	Calendar frame position	Specification
801 677	3 o'clock	3 o'clock	Black figures on gold background
801 678	3 o'clock	3 o'clock	Black figures on silver background
801 682	3 o'clock	3 o'clock	White figures on black background
801 716	3 o'clock	6 o'clock	Black figures on gold background
801 717	3 o'clock	6 o'clock	Black figures on silver background
801 718	3 o'clock	6 o'clock	white figures on black background

If any other type of date dial is required, specify ① Cal. No. ② The crown position ③ The calendar frame position and ④ Dial No.

CAL V333 A			
PARTS NO.	PARTS NAME	PARTS NO.	PARTS NAME
125 530	Train wheel bridge	802 530	Date driving wheel
• 221 530	Center wheel & pinion	808 530	Date dial guard
• 221 536	Center wheel & pinion	810 530	Date jumper
• 221 537	Center wheel & pinion	962 530	Intermediate wheel for calendar correction
231 530	Third wheel & pinion		
• 241 530	Fourth wheel & pinion	963 781	Snap for day star with dial disk
• 241 536	Fourth wheel & pinion	989 530	Intermediate wheel for day correction
• 241 537	Fourth wheel & pinion	4001 748	Circuit block
261 530	Minute wheel	4002 531	Coil block
• 271 530	Hour wheel	4148 531	Step rotor
• 271 536	Hour wheel	4239 530	Rotor stator
• 271 537	Hour wheel	4270 531	Battery connection (-)
281 530	Setting wheel	4271 533	Battery connection (+)
282 530	Clutch wheel	390 530	Setting lever pin
• 354 530	Winding stem	022 248	Date dial guard screw
383 530	Setting lever	022 410	Train wheel bridge screw
384 530	Yoke	022 410	Coil block screw
391 530	Train wheel setting lever	022 410	Battery connection (+) screw
• 470 756	Day star with dial disk		
701 530	Fifth wheel & pinion		
737 530	Calendar correction wheel		
• 801 659	Date dial		
		● SEIKO TR916SW	} Battery
		● MAXELL SR916SW	
		● MATSUSHITA SR916SW	

Remarks:

*** Winding stem**

The type of winding stem is determined based on the design of case. Check the case number and refer to "Casing Parts Catalogue" to choose a corresponding winding stem.

*** Center wheel & pinion, Fourth wheel & pinion, Hour wheel**

There are three different types as specified below.

Combination:

Type	Center wheel & pinion	Fourth wheel & pinion	Hour wheel
S	221 536	241 536	271 536
M	221 530	241 530	271 530
L	221 537	241 537	271 537

*Abbreviation S..... Short type
(Movement type) M.....Standard type
L..... Long type

*** Day star with dial disk (V333A)**

Parts No.	Combination of language	Ground color	Figure color
470 756	English + Spanish	Silver	Black
470 763	English + Spanish	Black	White
470 757	English + French	Silver	Black
470 764	English + French	Black	White
470 758	English + Italian	Silver	Black
470 765	English + Italian	Black	White
470 759	English + Japanese	Silver	Black
470 766	English + Japanese	Black	White
470 760	English + Roman Numeral	Silver	Black
470 767	English + Roman Numeral	Black	White
470 761	English + Arabic	Silver	Black
470 768	English + Arabic	Black	White
470 762	English + German	Silver	Black
470 769	English + German	Black	White

Used for both the crown and calendar frame at 3 o'clock position.

If any other type of day star with dial disk is required, specify the number printed on the disk.

*** Date dial**

Parts No.	Specification
801 658	Black figures on gold background
801 659	Black figures on silver background
801 680	White figures on black background

Used for both the crown and calendar frame at 3 o'clock position.

If any other type of date dial is required, specify ① Cal. No. ② The crown position ③ The calendar frame position and ④ Dial No.

CAL. V348 A			
PARTS NO.	PARTS NAME	PARTS NO.	PARTS NAME
125 530	Train wheel bridge	802 530	Date driving wheel
• 221 530	Center wheel & pinion	808 530	Date dial guard
• 221 536	Center wheel & pinion	810 530	Date jumper
• 221 537	Center wheel & pinion	962 530	Intermediate wheel for calendar correction
231 530	Third wheel & pinion		
• 241 530	Fourth wheel & pinion	963 781	Snap for day star with dial disk
• 241 536	Fourth wheel & pinion	989 530	Intermediate wheel for day correction
• 241 537	Fourth wheel & pinion	4001 748	Circuit block
261 530	Minute wheel	4002 531	Coil block
• 271 530	Hour wheel	4146 531	Step rotor
• 271 536	Hour wheel	4239 530	Rotor stator
• 271 537	Hour wheel	4270 531	Battery connection (-)
281 530	Setting wheel	4271 563	Battery connection (+)
282 530	Clutch wheel	390 530	Setting lever pin
• 354 530	Winding stem	022 248	Date dial guard screw
383 530	Setting lever	022 410	Train wheel bridge screw
384 530	Yoke	022 410	Coil block screw
391 530	Train wheel setting lever	022 410	Battery connection (+) screw
• 470 770	Day star with dial disk		
701 530	Fifth wheel & pinion	● SEIKO SR920SW	} Battery
737 530	Calendar correction wheel	● MAXELL SR920SW	
• 801 671	Date dial	● SONY EVEREADY 371	

Remarks:

*** Winding stem**

The type of winding stem is determined based on the design of case. Check the case number and refer to "Casing Parts Catalogue" to choose a corresponding winding stem.

*** Center wheel & pinion, Fourth wheel & pinion, Hour wheel**

There are three different types as specified below.

Combination:

Type	Center wheel & pinion	Fourth wheel & pinion	Hour wheel
S	221 536	241 536	271 536
M	221 530	241 530	271 530
L	221 537	241 537	271 537

*Abbreviation S..... Short type
(Movement type) M.....Standard type
L..... Long type

*** Day star with dial disk (V348A)**

Parts No.	Combination of language	Ground color	Figure color
470 770	English + Spanish	Silver	Black
470 777	English + Spanish	Black	White
470 771	English + French	Silver	Black
470 778	English + French	Black	White
470 772	English + Italian	Silver	Black
470 779	English + Italian	Black	White
470 773	English + Japanese	Silver	Black
470 804	English + Japanese	Black	White
470 774	English + Roman Numeral	Silver	Black
470 805	English + Roman Numeral	Black	White
470 775	English + Arabic	Silver	Black
470 806	English + Arabic	Black	White
470 776	English + German	Silver	Black
470 807	English + German	Black	White

Used for both the crown and calendar frame at 3 o'clock position.

If any other type of day star with dial disk is required, specify the number printed on the disk.

*** Date dial**

Parts No.	Specification
801 670	Black figures on gold background
801 671	Black figures on silver background
801 683	White figures on black background

Used for both the crown and calendar frame at 3 o'clock position.

If any other type of date dial is required, specify ① Cal. No. ② The crown position ③ The calendar frame position and ④ Dial No.