



technotime

© UP DATE 01.01.03 / PAGE 1

6130 D

6 3/4 x 8'''

15,30 x 17,80 mm

H = 2,55 mm

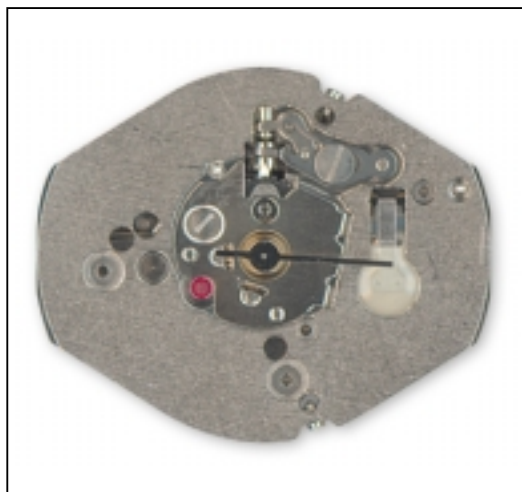

CARACTERISTIQUES TECHNIQUES

Cage

Dimensions totales
Dimensions encageage
Hauteur sur filet
Hauteur sur tige
Hauteur mouvement
Hauteur totale

Tige de mise à l'heure

Diamètre du filetage

Résonateur

Fréquence

Moteur

Nombre d'impulsions
par minute

Execution:

Swiss made: 5 rubis
french parts: 1 rubis

Finition:

Swiss made: doré
french parts: nickelé

TECHNICAL DATA

Frame

Overall dimensions
Casing dimensions
Height at bead
Height at stem
Movement height
Total height

Hand-setting stem

Threading diameter

Resonator

Frequency

Motor

Number of impulses p/minute

Version:

Swiss made: 5 jewels
Version: 1 jewel

Finishing:

Swiss made: gold plated
Version: nickel plated

TECHNISCHE DATEN

Gestell

Gesamte-Abmessungen	15,300mm x 18,200mm
Gehäuse-Passung	15,300mm x 17,800mm
Höhe am Wulst	0,600mm
Höhe an der Welle	1,000mm
Werkhöhe	2,550mm
Gesamte Höhe	2,600mm

Stellwelle

Gewindedurchmesser	0,900mm
--------------------	---------

Resonator

Frequenz	32 768 Hz
----------	-----------

Motor

Impulszahl p/Minute	60
---------------------	----

Ausführung:

Swiss made: 5 Steine
Ausführung: 1 Stein

Ausführung:

Swiss made: vergoldet
Ausführung: vernickelst

technotime

www.technotime.com

TECHNOTIME SA

Site Dubied 10
2108 COUVET - SUISSE
Tél: +41 (0) 32 864 90 10
Fax: +41 (0) 32 864 90 19
Email: tt@technotime.com

TECHNOTIME MICROTECHNIQUE SAS

2, Rue de l'Industrie
25800 VALDAHON - FRANCE
Tél: 33 (0) 3 81 56 78 00
Fax: 33 (0) 3 81 56 78 03
Email: tt.microtechnique@technotime.com

TECHNOTIME ASIA LTD

21st floor Lee Fund Centre,
31 Wong Chuk Hang Road
Aberdeen - HONG KONG
Tél: (852) 25551879
Fax: (852) 25544359
Email: tt.asia@technotime.com

6130 D



6 3/4 x 8'''

15,30 x 17,80 mm

H = 2,55 mm

© UP DATE 01.01.03 / PAGE 2

CONTRÔLES TESTS KONTROLLEN

Position Messpunkt	CONTRÔLES ÉLECTRIQUES	ELECTRICAL TESTS	ELEKTRISCHE KONTROLLEN
①	- Tension de la pile	- Battery voltage	- Spannung der Batterie
②	- Alimentation du circuit (pile enlevée)	- Supply of circuit (remoted battery)	- Speisung Schaltung (entfernte Batterie)
③ a	- Consommation du circuit seul (pile enlevée)	- Consumption of circuit only (remoted battery)	- Stromverbrauch der Schaltung allein (entfernte Batterie)
③ b	- Consommation moyenne du mouvement (pile enlevée, tige poussée)	- Average consumption of movement (remoted Battery, pushed-shaft)	- Durchschnittlicher Stromverbrauch vom Werke (entfernte Batterie, eingedrückte Stellwelle)
④	- Resistance de la bobine (avec ou sans protection de bobine, pile enlevée)	- Resistance of coil (with or without coil guard, remoted battery)	- Widerstand der Spule (mit oder ohne Spulenschutz, entfernte batterie)
⑤	- Impulsion moteur	- Motor impulses	- Impulsen Motor
⑥	- Resistance de la bobine	- Resistance of coil	- Widerstand der Spule
⑦	- Isolation du bobinage	- Insulation of coil	- Isolierung der Spule

1.5 K Ω

Pile	Batterie	Battery
SR621SW (364)		

**Fonctions de la tige
Handsetting-stem functions
Funktionen der Stellwelle**

- 1 Marche normale
- 2 Mise à l'heure, stop-seconde avec interruption du courant pour le moteur

- 1 Regular running
- 2 Handsetting, stop-second with interruption of current to the motor

- 1 Normaler Gang
- 2 Zeigerstellen, Sekunden-Stopp mit Unterbrechung der Motorspeisung

Position Position Messpunkt	①	②	③ a (Fonction stop - stop fonction - Stopp Stellung)	③ b	⑤	④ ⑥	⑦
Echelle de mesure Measuring range Messbereich	2 V	2 V	10 μ A	10 μ A	2 V	0.2 V maxi. 10 K Ω	0.2 V maxi. 10 K Ω
Mesure Measurement Messung	1.55 V	1.55 V	1 S 0.15 μ A - 0.30 μ A	1 S 0.50 μ A - 1.10 μ A	= 1 S	= 1470 Ω	∞

www.technotime.com

TECHNOTIME SA
 Site Dubied 10
 2108 COUVET - SUISSE
 Tél: +41 (0) 32 864 90 10
 Fax: +41 (0) 32 864 90 19
 Email: tt@technotime.com

**TECHNOTIME
MICROTECHNIQUE SAS**
 2, Rue de l'Industrie
 25800 VALDAHON - FRANCE
 Tél: 33 (0) 3 81 56 78 00
 Fax: 33 (0) 3 81 56 78 03
 Email: tt.microtechnique@technotime.com

**TECHNOTIME
ASIA LTD**
 21st floor Lee Fund Centre,
 31 Wong Chuk Hang Road
 Aberdeen - HONG KONG
 Tél: (852) 25551879
 Fax: (852) 25544359
 Email: tt.asia@technotime.com

6130 D



6 3/4 x 8'''

15,30 x 17,80 mm

H = 2,55 mm

© UP DATE 01.01.03 / PAGE 3

AIGUILLAGE

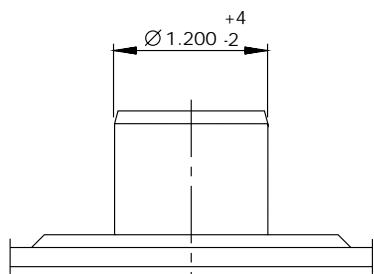

Roue des heures
Hour wheel
Stundenrad

HAND-FITTING

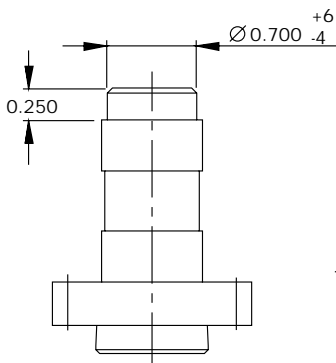

Chaussée
Cannon pinion
Minutenrohr

ZEIGERSETZEN

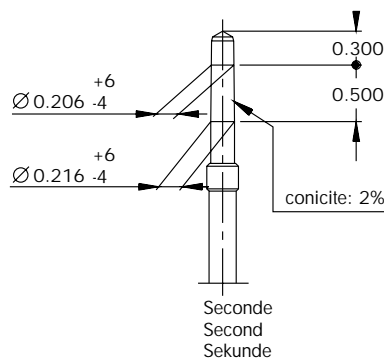

Seconde
Second
Sekunde

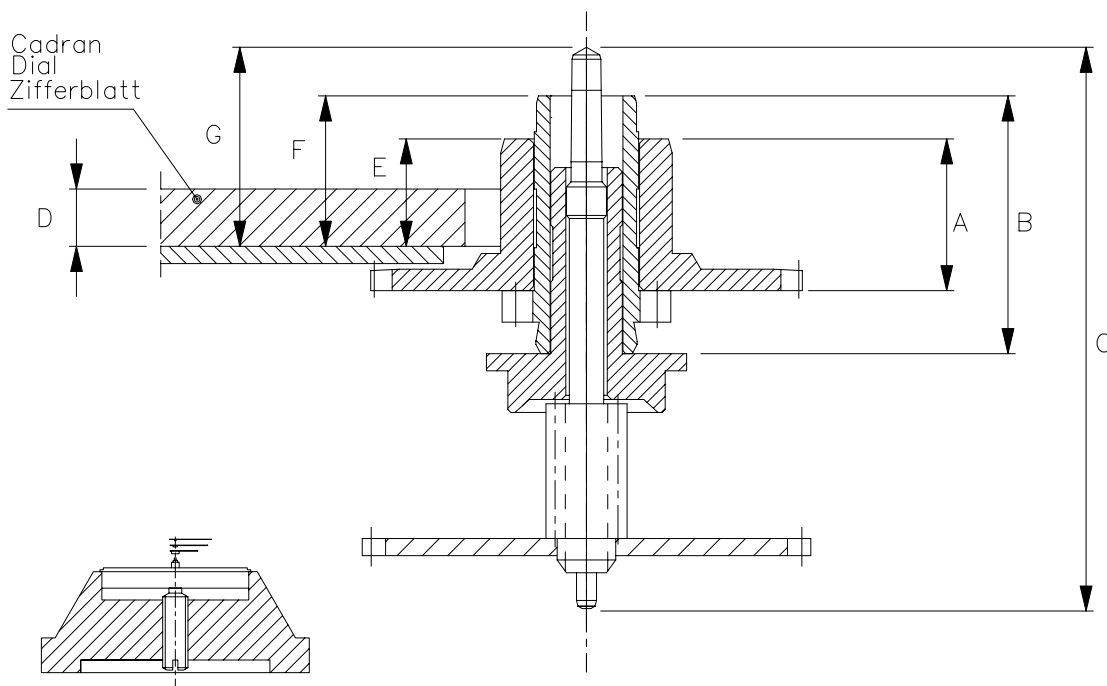

ATTENTION : CHASSAGE DES AIGUILLES, UTILISER UN PORTE-PIECES A VIS
 NOTICE : FOR DRIVING IN OF THE HANDS USE MOVEMENT HOLDER WITH SCREW
 ACHTUNG : ZUM EINPRESSEN VON DER ZEIGER VERWENDEN SIE EINEN WERKHALTER MIT STUETZSCHRAUBE

N° aiguillage	A	B	C	D	E	F	G
0	0.910	1.650	3.720	0.300	0.600	0.900	1.170
1	1.060	1.800	3.920	0.400	0.750	1.050	1.370
2	1.260	2.050	4.220	...	0.950	1.300	1.670
3	1.560	2.350	4.520	...	1.250	1.600	1.970



TECHNOTIME SA

Site Dubied 10
 2108 COUVET - SUISSE
 Tél: +41 (0) 32 864 90 10
 Fax: +41 (0) 32 864 90 19
 Email: tt@technotime.com

TECHNOTIME MICROTECHNIQUE SAS

2, Rue de l'Industrie
 25800 VALDAHON - FRANCE
 Tél: 33 (0) 3 81 56 78 00
 Fax: 33 (0) 3 81 56 78 03
 Email: tt.microtechnique@technotime.com

TECHNOTIME ASIA LTD

21st floor Lee Fund Centre,
 31 Wong Chuk Hang Road
 Aberdeen - HONG KONG
 Tél: (852) 25551879
 Fax: (852) 25544359
 Email: tt.asia@technotime.com

6130 D



6 3/4 x 8'''

15,30 x 17,80 mm

H = 2,55 mm

© UP DATE 01.01.03 / PAGE 4

AIGUILLES HANDS ZEIGER

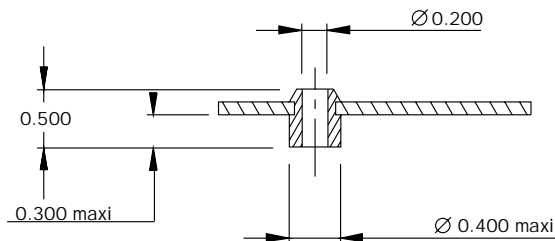

Aiguillage n°1 cadran D à 0.400
N°1 hand-fitting with dial D at 0.400
N°1 Zeigersetzen mit Zifferblatt D 0.400

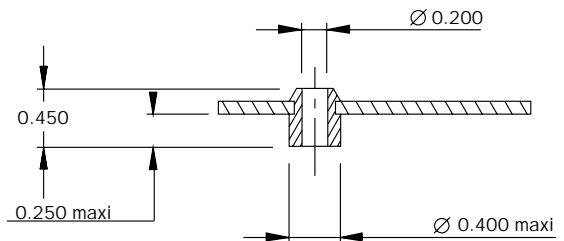

Aiguillage n°0 cadran D à 0.300
N°0 hand-fitting with dial D at 0.300
N°0 Zeigersetzen mit Zifferblatt D 0.300

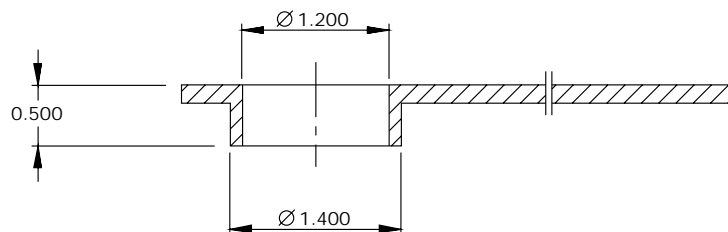
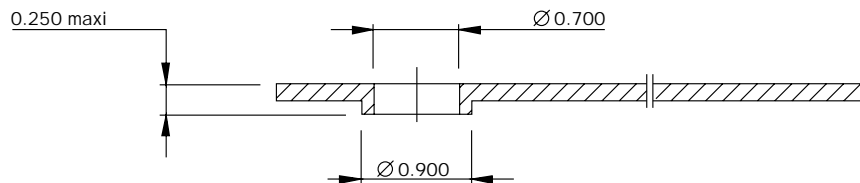

technotime
www.technotime.com

TECHNOTIME SA

Site Dubied 10
2108 COUVET - SUISSE
Tél: +41 (0) 32 864 90 10
Fax: +41 (0) 32 864 90 19
Email: tt@technotime.com

TECHNOTIME MICROTECHNIQUE SAS

2, Rue de l'Industrie
25800 VALDAHON - FRANCE
Tél: 33 (0) 3 81 56 78 00
Fax: 33 (0) 3 81 56 78 03
Email: tt.microtechnique@technotime.com

TECHNOTIME ASIA LTD

21st floor Lee Fund Centre,
31 Wong Chuk Hang Road
Aberdeen - HONG KONG
Tél: (852) 25551879
Fax: (852) 25544359
Email: tt.asia@technotime.com

6130 D



6 3/4 x 8'''

15,30 x 17,80 mm

H = 2,55 mm

© UP DATE 01.01.03 / PAGE 5

CAGE POUR BOÎTE

FRAME FOR CASE

GESTELL FÜR GEHAUSE

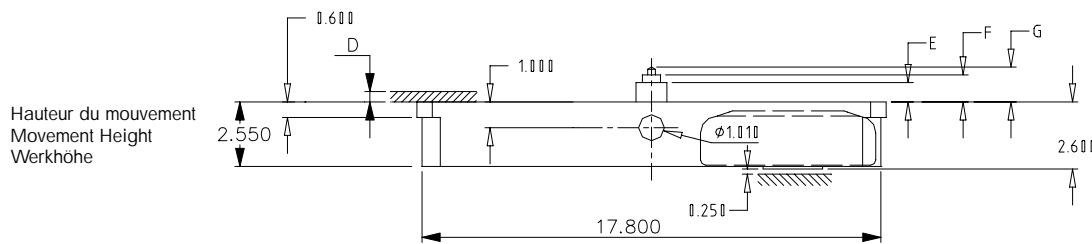

Hauteur du mouvement
Movement Height
Werkhöhe

Hauteur avec pile
Total Height with Battery
Gesamthöhe mit Batterie

N° aiguillage	D	E	F	G
0	0.300	0.600	0.900	1.170
1	0.400	0.750	1.050	1.370
2	...	0.950	1.300	1.670
3	...	1.250	1.600	1.970

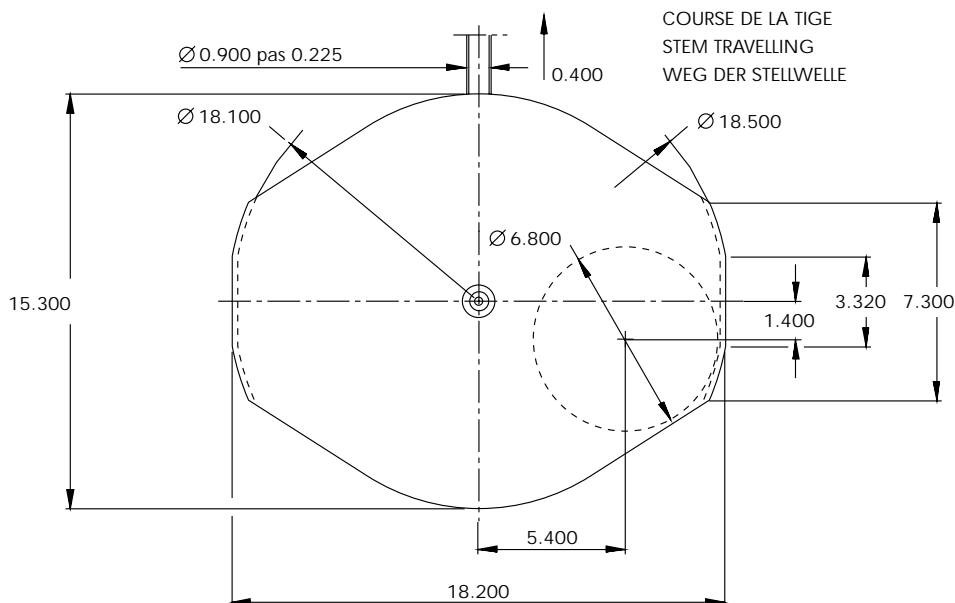

COURSE DE LA TIGE
STEM TRAVELLING
WEG DER STELLWELLE



TECHNOTIME SA

Site Dubied 10
2108 COUVET - SUISSE
Tél: +41 (0) 32 864 90 10
Fax: +41 (0) 32 864 90 19
Email: tt@technotime.com

TECHNOTIME MICROTECHNIQUE SAS

2, Rue de l'Industrie
25800 VALDAHON - FRANCE
Tél: 33 (0) 3 81 56 78 00
Fax: 33 (0) 3 81 56 78 03
Email: tt.microtechnique@technotime.com

TECHNOTIME ASIA LTD

21st floor Lee Fund Centre,
31 Wong Chuk Hang Road
Aberdeen - HONG KONG
Tél: (852) 25551879
Fax: (852) 25544359
Email: tt.asia@technotime.com

6130 D



6 3/4 x 8'''

15,30 x 17,80 mm

H = 2,55 mm

© UP DATE 01.01.03 / PAGE 6

CADRAN DIAL ZIFFERBLATT

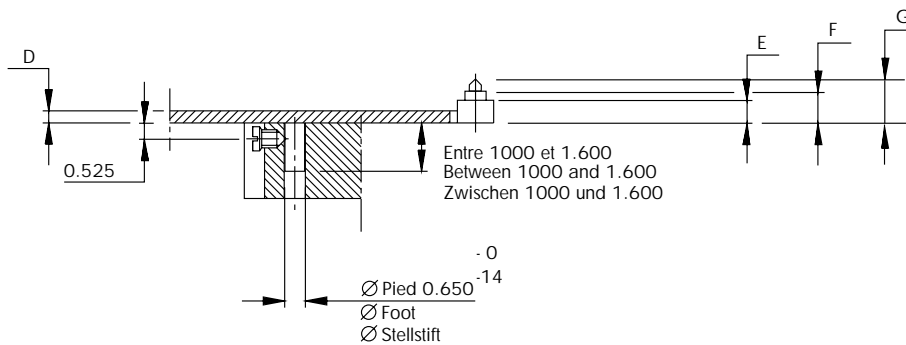

N° aiguillage	D	E	F	G
0	0.300	0.600	0.900	1.170
1	0.400	0.750	1.050	1.370
2	...	0.950	1.300	1.670
3	...	1.250	1.600	1.970

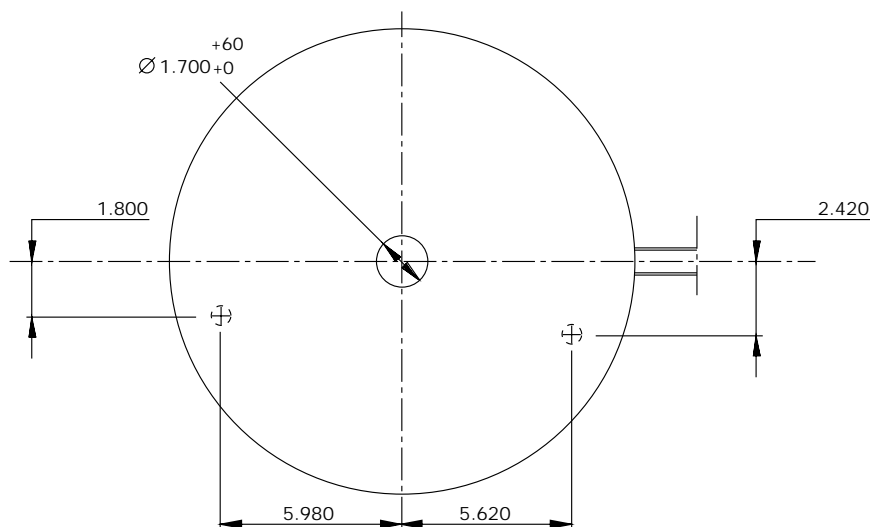

TECHNOTIME SA

Site Dubied 10
2108 COUVET - SUISSE
Tél: +41 (0) 32 864 90 10
Fax: +41 (0) 32 864 90 19
Email: tt@technotime.com

TECHNOTIME MICROTECHNIQUE SAS

2, Rue de l'Industrie
25800 VALDAHON - FRANCE
Tél: 33 (0) 3 81 56 78 00
Fax: 33 (0) 3 81 56 78 03
Email: tt.microtechnique@technotime.com

TECHNOTIME ASIA LTD

21st floor Lee Fund Centre,
31 Wong Chuk Hang Road
Aberdeen - HONG KONG
Tél: (852) 25551879
Fax: (852) 25544359
Email: tt.asia@technotime.com