



technotime

© UP DATE 01.01.03 / PAGE 1

6320 D

6 3/4 x 8'''

15,30 x 17,80 mm

H = 3,250 mm



CARACTERISTIQUES TECHNIQUES

Cage

Dimensions totales
Dimensions encageage
Hauteur sur filet
Hauteur sur tige
Hauteur mouvement
Hauteur totale

Tige de mise à l'heure

Diamètre du filetage

Résonateur

Fréquence

Moteur

Nombre d'impulsions
par minute

Execution:

Swiss made: 1 rubis
French parts: 1 rubis

Finition:

Swiss made: nickelé
French parts: nickelé

TECHNICAL DATA

Frame

Overall dimensions
Casing dimensions
Height at bead
Height at stem
Movement height
Total height

Hand-setting stem

Threading diameter

Resonator

Frequency

Motor

Number of impulses p/minute

Version:

Swiss made: 1 jewel
French parts: 1 jewel

Finishing:

Swiss made: nickel plated
French parts: nickel plated

TECHNISCHE DATEN

Gestell

Gesamte-Abmessungen	15,300mm x 18,200mm
Gehäuse-Passung	15,300mm x 17,800mm
Höhe am Wulst	0,850mm
Höhe an der Welle	1,700mm
Werkhöhe	3,250mm
Gesamte Höhe	3,300mm

Stellwelle

Gewindedurchmesser	0,900mm
--------------------	---------

Resonator

Frequenz	32 768 Hz
----------	-----------

Motor

Impulszahl p/Minute	3
---------------------	---

Ausführung:

Swiss made: 1 Stein
French parts: 1 Stein

Ausführung:

Swiss made: vernickelet
French parts: vernickelet

technotime
www.technotime.com

TECHNOTIME SA

Site Dubied 10
2108 COUVET - SUISSE
Tél: +41 (0) 32 864 90 10
Fax: +41 (0) 32 864 90 19
Email: tt@technotime.com

TECHNOTIME MICROTECHNIQUE SAS

2, Rue de l'Industrie
25800 VALDAHON - FRANCE
Tél: 33 (0) 3 81 56 78 00
Fax: 33 (0) 3 81 56 78 03
Email: tt.microtechnique@technotime.com

TECHNOTIME ASIA LTD

21st floor Lee Fund Centre,
31 Wong Chuk Hang Road
Aberdeen - HONG KONG
Tél: (852) 25551879
Fax: (852) 25544359
Email: tt.asia@technotime.com

6320 D



6 3/4 x 8'''

15,30 x 17,80 mm
H = 3,250 mm

© UP DATE 01.01.03 / PAGE 2

CONTRÔLES TESTS KONTROLLEN

Position Messpunkt	CONTRÔLES ÉLECTRIQUES	ELECTRICAL TESTS	ELEKTRISCHE KONTROLLEN
①	- Tension de la pile	- Battery voltage	- Spannung der Batterie
②	- Alimentation du circuit (pile enlevée)	- Supply of circuit (remoted battery)	- Speisung Schaltung (entfernte Batterie)
③ a	- Consommation du circuit seul (pile enlevée)	- Consumption of circuit only (remoted battery)	- Stromverbrauch der Schaltung allein (entfernte Batterie)
③ b	- Consommation moyenne du mouvement (pile enlevée, tige poussée)	- Average consumption of movement (remoted Battery, pushed-shaft)	- Durchschnittlicher Stromverbrauch vom Werke (entfernte Batterie, eingedrückte Stellwelle)
④	- Resistance de la bobine (avec ou sans protection de bobine, pile enlevée)	- Resistance of coil (with or without coil guard, remoted battery)	- Widerstand der Spule (mit oder ohne Spulenschutz, entfernte batterie)
⑤	- Impulsion moteur	- Motor impulses	- Impulsen Motor
⑥	- Resistance de la bobine	- Resistance of coil	- Widerstand der Spule
⑦	- Isolation du bobinage	- Insulation of coil	- Isolation of Spule

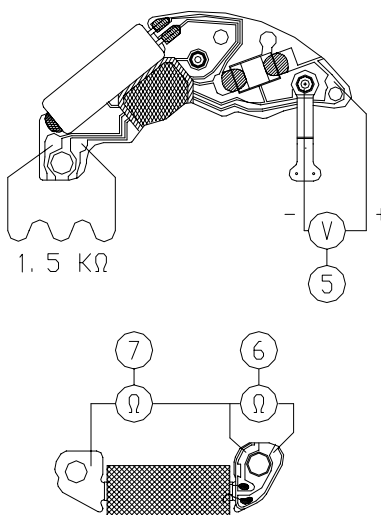
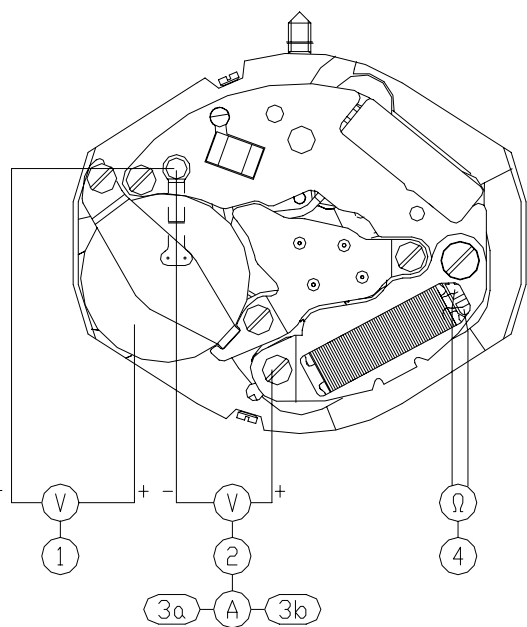

Fonctions de la tige Handsetting-stem functions Funktionen der Stellwelle



- 1 Marche normale
- 2 Mise à l'heure
- 1 Regular running
- 2 Handssetting
- 1 Normaler Gang
- 2 Zeigerstellen

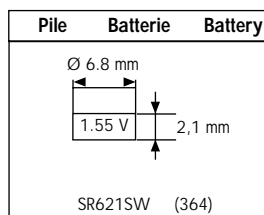

Position Position Messpunkt	①	②	③ a	③ b	⑤	④ ⑥	⑦
Echelle de mesure Measuring range Messbereich	2 V	2 V	10 μA	10 μA	2 V	0.2 V maxi. 10 KΩ	0.2 V maxi. 10 KΩ
Mesure Measurement Messung	1.55 V	1.55 V	1 S 0.15 μA - 0.30 μA	int 20 S 0.40 μA - 0.80 μA	= 20 S	= 1470 Ω	∞



TECHNOTIME SA

Site Dubied 10
2108 COUVET - SUISSE
Tél: +41 (0) 32 864 90 10
Fax: +41 (0) 32 864 90 19
Email: tt@technotime.com

TECHNOTIME MICROTECHNIQUE SAS

2, Rue de l'Industrie
25800 VALDAHON - FRANCE
Tél: 33 (0) 3 81 56 78 00
Fax: 33 (0) 3 81 56 78 03
Email: tt.microtechnique@technotime.com

TECHNOTIME ASIA LTD

21st floor Lee Fund Centre,
31 Wong Chuk Hang Road
Aberdeen - HONG KONG
Tél: (852) 25551879
Fax: (852) 25544359
Email: tt.asia@technotime.com

6320 D



6 3/4 x 8'''

15,30 x 17,80 mm

H = 3,250 mm

© UP DATE 01.01.03 / PAGE 3

AIGUILLAGE HAND-FITTING ZEIGERSETZEN

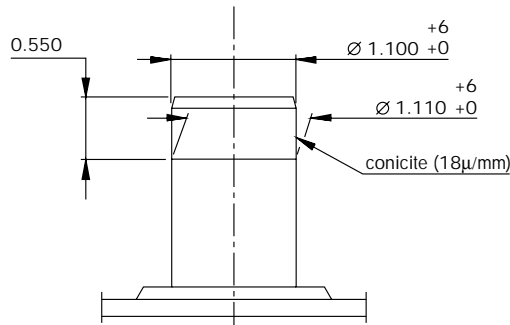

Roue des heures
Hour wheel
Stundenrad

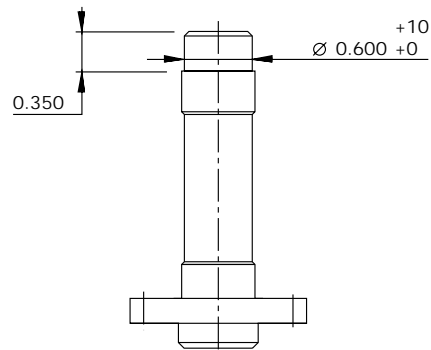

Chaussee
Cannon pinion
Minutenrohr

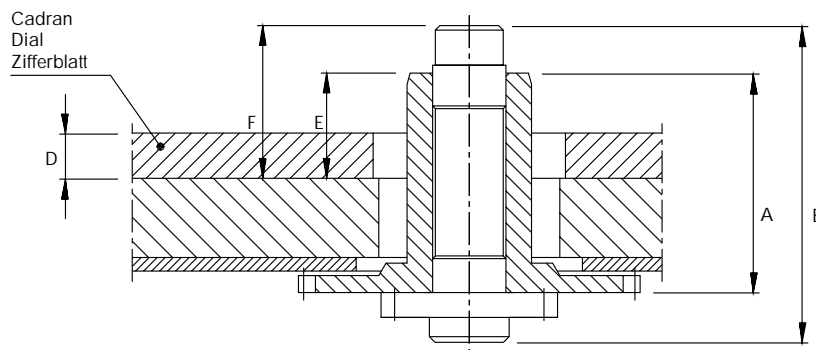

N° aiguillage	A	B	D	E	F
1	1.940	2.800	0.400	0.930	1.350

6320 D



6 3/4 x 8'''

15,30 x 17,80 mm

H = 3,250 mm

© UP DATE 01.01.03 / PAGE 4

AIGUILLES HANDS ZEIGER

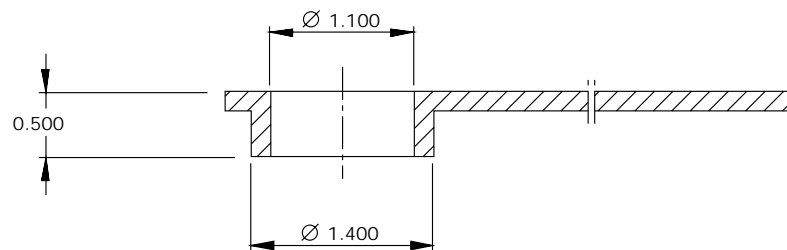
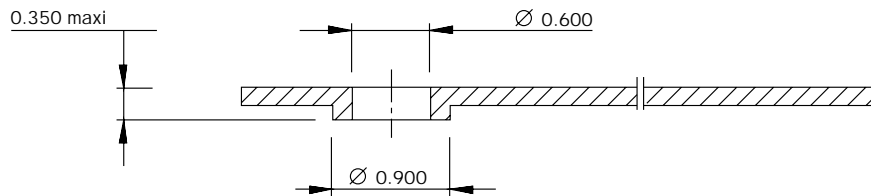

TECHNOTIME SA

Site Dubied 10
2108 COUVET - SUISSE
Tél: +41 (0) 32 864 90 10
Fax: +41 (0) 32 864 90 19
Email: tt@technotime.com

**TECHNOTIME
MICROTECHNIQUE SAS**

2, Rue de l'Industrie
25800 VALDAHON - FRANCE
Tél: 33 (0) 3 81 56 78 00
Fax: 33 (0) 3 81 56 78 03
Email: tt.microtechnique@technotime.com

**TECHNOTIME
ASIA LTD**

21st floor Lee Fund Centre,
31 Wong Chuk Hang Road
Aberdeen - HONG KONG
Tél: (852) 25551879
Fax: (852) 25544359
Email: tt.asia@technotime.com

6320 D



6 3/4 x 8'''

15,30 x 17,80 mm

H = 3,250 mm

© UP DATE 01.01.03 / PAGE 5

CAGE POUR BOÎTE

FRAME FOR CASE

GESTELL FÜR GEHAUSE

Hauteur du mouvement
Movement Height
Werkhöhe

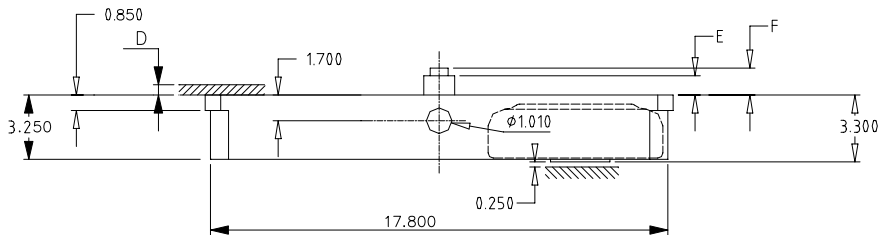

Hauteur avec pile
Total Height with Battery
Gesamthöhe mit Batterie

N° aiguillage	D	E	F
1	0.400	0.930	1.350

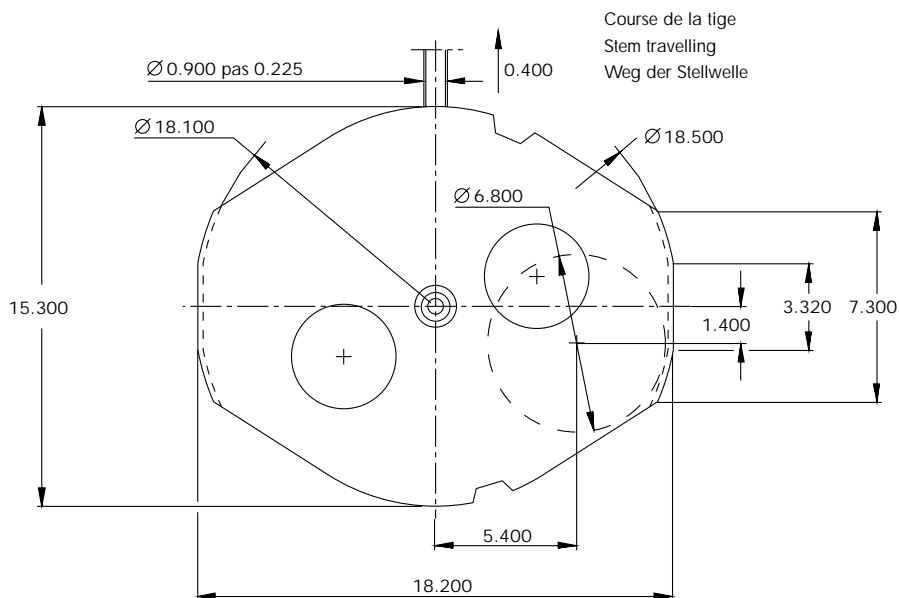

Course de la tige
Stem travelling
Weg der Stellwelle



technotime
www.technotime.com

TECHNOTIME SA

Site Dubied 10
2108 COUVET - SUISSE
Tél: +41 (0) 32 864 90 10
Fax: +41 (0) 32 864 90 19
Email: tt@technotime.com

TECHNOTIME MICROTECHNIQUE SAS

2, Rue de l'Industrie
25800 VALDAHON - FRANCE
Tél: 33 (0) 3 81 56 78 00
Fax: 33 (0) 3 81 56 78 03
Email: tt.microtechnique@technotime.com

TECHNOTIME ASIA LTD

21st floor Lee Fund Centre,
31 Wong Chuk Hang Road
Aberdeen - HONG KONG
Tél: (852) 25551879
Fax: (852) 25544359
Email: tt.asia@technotime.com

6320 D



6 3/4 x 8'''

15,30 x 17,80 mm

H = 3,250 mm

© UP DATE 01.01.03 / PAGE 6

CADRAN DIAL ZIFFERBLATT

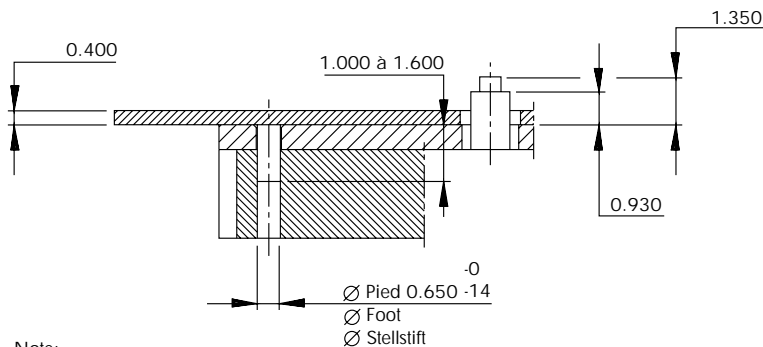

Note:

Possibilité d'utiliser les vis de la platine pour la fixation du cadran (sans gommettes). Pieds longueur 1.600 mm mini.

Zone de collage du cadran

Aera's glue of the dial

Positionierungspunkt des Klebstoffes unter dem Zifferblatt

(Gommettes)

Ø 4.000

1.800

+60

Ø 1.700+0

2.420

5.980

5.620



www.technotime.com

TECHNOTIME SA

Site Dubied 10
2108 COUVET - SUISSE
Tél: +41 (0) 32 864 90 10
Fax: +41 (0) 32 864 90 19
Email: tt@technotime.com

TECHNOTIME MICROTECHNIQUE SAS

2, Rue de l'Industrie
25800 VALDAHON - FRANCE
Tél: 33 (0) 3 81 56 78 00
Fax: 33 (0) 3 81 56 78 03
Email: tt.microtechnique@technotime.com

TECHNOTIME ASIA LTD

21st floor Lee Fund Centre,
31 Wong Chuk Hang Road
Aberdeen - HONG KONG
Tél: (852) 25551879
Fax: (852) 25544359
Email: tt.asia@technotime.com