



# technotime

© UP DATE 01.01.03 / PAGE 1

## 70200 B

H = 3,00 mm
8 3/4''' ø 19,4 mm



### CARACTERISTIQUES TECHNIQUES

#### Cage

Diamètre total  
Diamètre encageage

Hauteur sur filet  
Hauteur sur tige  
Hauteur mouvement  
Hauteur totale

#### Tige de mise à l'heure

Diamètre du filetage

#### Résonateur

Fréquence

#### Moteur

Nombre d'impulsions  
par minute

#### Execution:

Swiss made: 7 rubis  
french parts: 1 rubis

#### Finition:

Swiss made: doré  
french parts: nickelé

### TECHNICAL DATA

#### Frame

Overall diameter  
Casing diameter

Height at bead  
Height at stem  
Movement height  
Total height

#### Hand-setting stem

Threading diameter

#### Resonator

Frequency

#### Motor

Number of impulses p/minute

#### Version:

Swiss made: 7 jewels  
Version: 1 jewel

#### Finishing:

Swiss made: gold plated  
Version: nickel plated

### TECHNISCHE DATEN

#### Gestell

Gesamte-Durchmesser  
Durchmesser zur Gehäuse-  
Passung

Höhe am Wulst  
Höhe an der Welle  
Werkhöhe  
Gesamte Höhe

#### Stellwelle

Gewindedurchmesser

#### Resonator

Frequenz

#### Motor

Impulszahl p/Minute

#### Ausführung:

Swiss made: 7 Steine  
Ausführung: 1 Stein

#### Ausführung:

Swiss made: vergoldet  
Ausführung: vernickelet

### 70200 B

20,000mm  
19,400mm

1,100mm  
1,500mm  
3,000mm  
3,100mm

0,900mm

32 768 Hz

60

  
**technotime**  
www.technotime.com

### TECHNOTIME SA

Site Dubied 10  
2108 COUVET - SUISSE  
Tél: +41 (0) 32 864 90 10  
Fax: +41 (0) 32 864 90 19  
Email: tt@technotime.com

### TECHNOTIME MICROTECHNIQUE SAS

2, Rue de l'Industrie  
25800 VALDAHON - FRANCE  
Tél: 33 (0) 3 81 56 78 00  
Fax: 33 (0) 3 81 56 78 03  
Email: tt.microtechnique@technotime.com

### TECHNOTIME ASIA LTD

21st floor Lee Fund Centre,  
31 Wong Chuk Hang Road  
Aberdeen - HONG KONG  
Tél: (852) 25551879  
Fax: (852) 25544359  
Email: tt.asia@technotime.com

70200 B



8 3/4'''  
 ø 19,4 mm  
 H = 3,00 mm

© UP DATE 01.01.03 / PAGE 2

## CONTRÔLES TESTS KONTROLLEN

Position Position Messpunkt	Echelle de mesure Measuring range Messbereich	Mesure Measurement Messung	Contrôle Test Kontrolle	Remarques Remarks Bemerkungen
1	2 V	1,55 V	Tension de la pile Battery voltage Spannung der Batterie	
2	2 V	Le mouvement doit fonctionner sous 1,35 V The movement must be running under 1,35 V Das Werk muss unter 1,35 V Spannung laufen	Limite inférieure de la tension de fonctionnement Lower working voltage limit Untere Funktionsspannungsgrenze	Pile enlevée Vis de bride serrée Alimentation extérieure
	10 µA - 1,55 V	0,6 µA ≤   ≤ 1,4 µA	Consommation du mouvement Consumption of movement Stromverbrauch vom Werke	Remoted battery Tightened bridle screw Outside power supply
	10 µA - 1,55 V	0,1 µA ≤   ≤ 0,4 µA	Consommation en fonction stop Tige en position 3 Consumption in stop position Handsetting stem in position 3 Stromverbrauch in Stop-Stellung Stellewelle in Stellung 3	Enlevée Batterie Angezogene Bügelschraube Speizegerät
3	Ω - 0,2 V maxi	1200 Ω < R < 1400 Ω	Résistance de la bobine Resistance of coil Widerstand der Spule	Pile et écran magnétique enlevés Battery and magnetic screen remoted Batterie und Magnetschirm entfernt

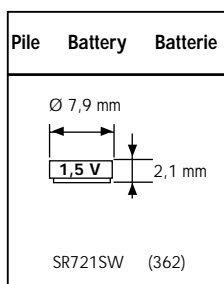
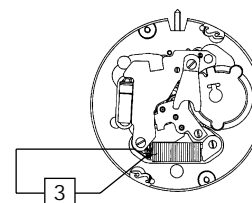
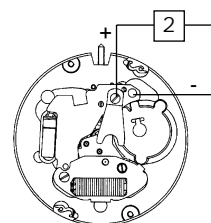
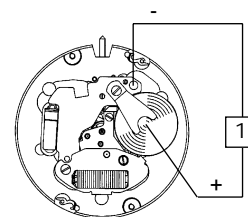

Fonctions de la tige Handsetting-stem functions	Funktionen der Stellewelle
	1 Marche normale 1 Normaler Gang  3 Mise à l'heure, stop-seconde avec interruption du courant pour le moteur 3 Zeigerstellen, SekundenStopp mit Unterbrechung der Motorspeisung  1 Regular running  3 Handsetting, stop-second with interruption of current to the motor

www.technotime.com

### TECHNOTIME SA

Site Dubied 10  
 2108 COUVET - SUISSE  
 Tél: +41 (0) 32 864 90 10  
 Fax: +41 (0) 32 864 90 19  
 Email: tt@technotime.com

### TECHNOTIME MICROTECHNIQUE SAS

2, Rue de l'Industrie  
 25800 VALDAHON - FRANCE  
 Tél: 33 (0) 3 81 56 78 00  
 Fax: 33 (0) 3 81 56 78 03  
 Email: tt.microtechnique@technotime.com

### TECHNOTIME ASIA LTD

21st floor Lee Fund Centre,  
 31 Wong Chuk Hang Road  
 Aberdeen - HONG KONG  
 Tél: (852) 25551879  
 Fax: (852) 25544359  
 Email: tt.asia@technotime.com

70200 B



**technotime**

8 3/4'''  
 ∅ 19,4 mm  
 H = 3,00 mm

© UP DATE 01.01.03 / PAGE 3

**AIGUILLAGE**

**HAND-FITTING**

**ZEIGERSETZEN**

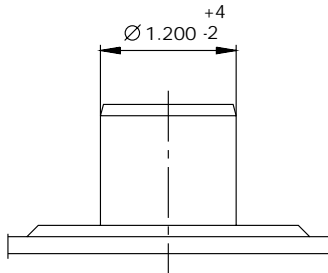

Roue des heures  
 Hour weehl  
 Stundenrad

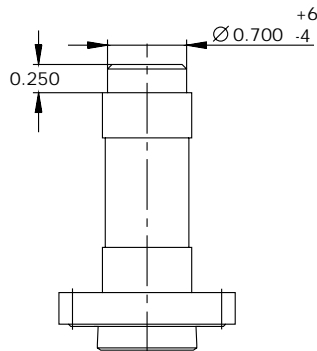

Chaussee  
 Cannon pinion  
 Minutenrohr

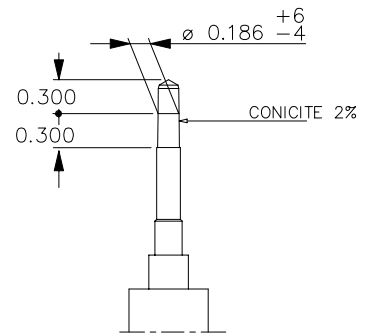

Petite seconde  
 Small second  
 Kleine Sekunde

Cadran  
 Dial  
 Zifferblatt

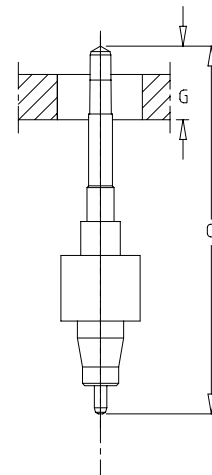
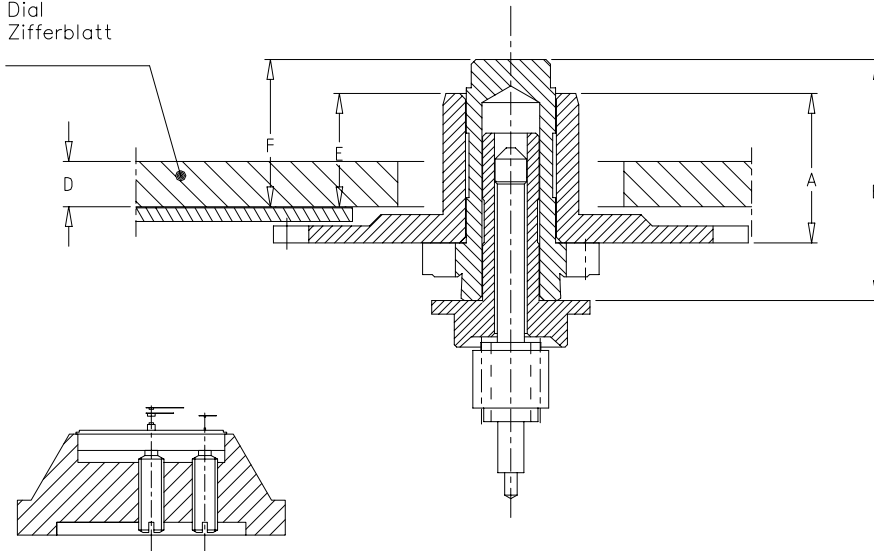

ATTENTION : CHASSAGE DES AIGUILLES, UTILISER UN PORTE-PIECES A VIS  
 NOTICE : FOR DRIVING IN OF THE HANDS USE MOVEMENT HOLDER WITH SCREW  
 ACHTUNG : ZUM EINPRESSEN VON DER ZEIGER VERWENDEN SIE EINEN WERKHALTER MIT STUETZSCHRAUBE

N° aiguillage	A	B	C	D	E	F	G
1	1.320	2.130	3.250	0.400	1.000	1.300	0.650

**technotime**  
 www.technotime.com

**TECHNOTIME SA**  
 Site Dubied 10  
 2108 COUVET - SUISSE  
 Tél: +41 (0) 32 864 90 10  
 Fax: +41 (0) 32 864 90 19  
 Email: tt@technotime.com

**TECHNOTIME  
 MICROTECHNIQUE SAS**  
 2, Rue de l'Industrie  
 25800 VALDAHON - FRANCE  
 Tél: 33 (0) 3 81 56 78 00  
 Fax: 33 (0) 3 81 56 78 03  
 Email: tt.microtechnique@technotime.com

**TECHNOTIME  
 ASIA LTD**  
 21st floor Lee Fund Centre,  
 31 Wong Chuk Hang Road  
 Aberdeen - HONG KONG  
 Tél: (852) 25551879  
 Fax: (852) 25544359  
 Email: tt.asia@technotime.com

70200 B



**technotime**

**8 3/4'''**  
Ø 19,4 mm  
H = 3,00 mm

© UP DATE 01.01.03 / PAGE 4

## AIGUILLES HANDS ZEIGER

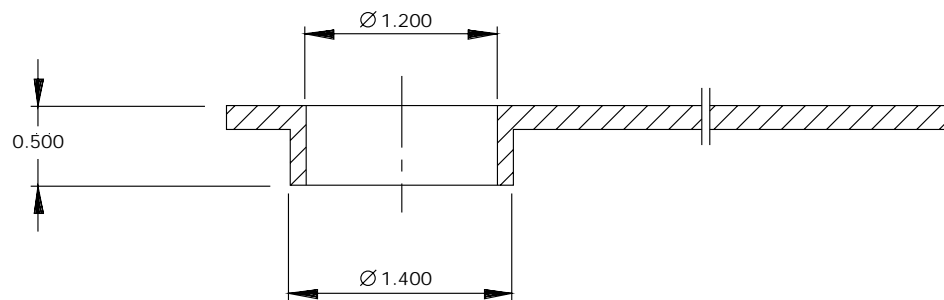
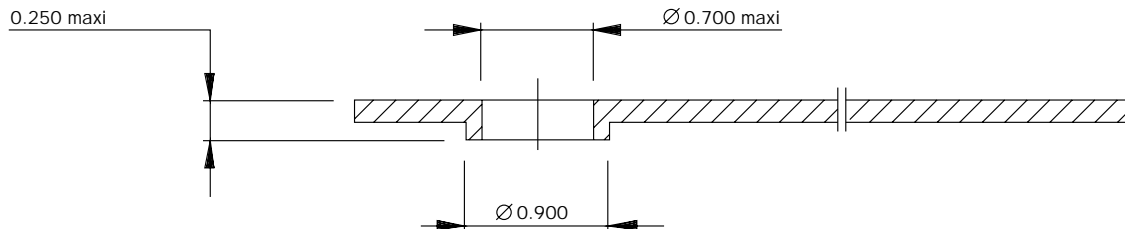
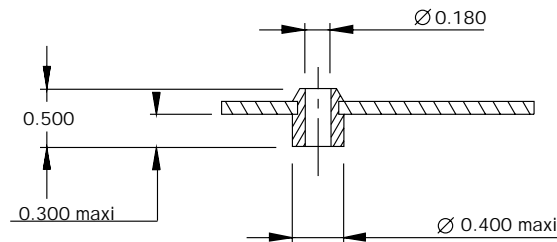

  
**technotime**  
www.technotime.com

### TECHNOTIME SA

Site Dubied 10  
2108 COUVET - SUISSE  
Tél: +41 (0) 32 864 90 10  
Fax: +41 (0) 32 864 90 19  
Email: tt@technotime.com

### TECHNOTIME MICROTECHNIQUE SAS

2, Rue de l'Industrie  
25800 VALDAHON - FRANCE  
Tél: 33 (0) 3 81 56 78 00  
Fax: 33 (0) 3 81 56 78 03  
Email: tt.microtechnique@technotime.com

### TECHNOTIME ASIA LTD

21st floor Lee Fund Centre,  
31 Wong Chuk Hang Road  
Aberdeen - HONG KONG  
Tél: (852) 25551879  
Fax: (852) 25544359  
Email: tt.asia@technotime.com

70200 B



8 3/4"  
 ∅ 19,4 mm  
 H = 3,00 mm

© UP DATE 01.01.03 / PAGE 5

EMBOÎTAGE CASING EINSCHALEN

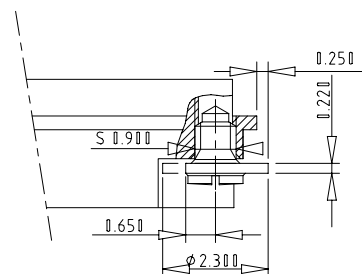
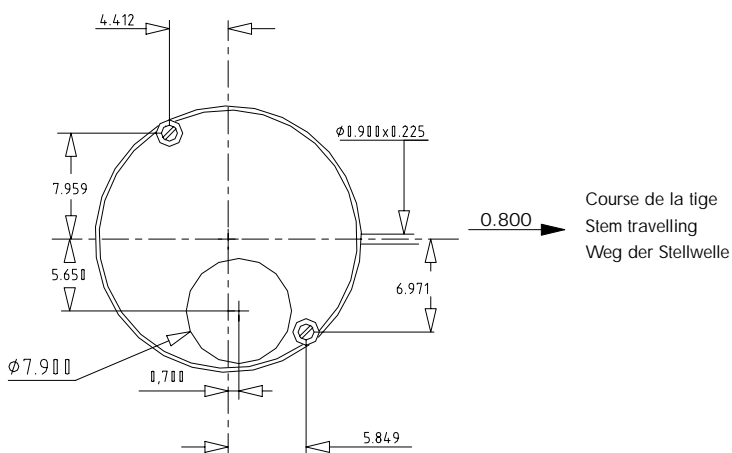
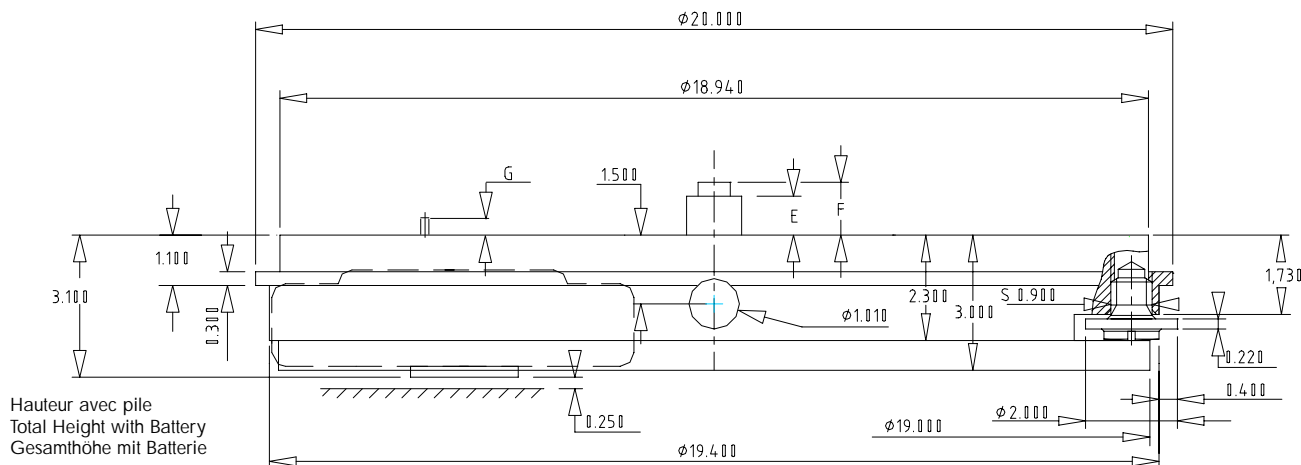

N° aiguillage	E	F	G
1	1.000	1.300	0.650



**TECHNOTIME SA**  
 Site Dubied 10  
 2108 COUVET - SUISSE  
 Tél: +41 (0) 32 864 90 10  
 Fax: +41 (0) 32 864 90 19  
 Email: tt@technotime.com

**TECHNOTIME  
 MICROTECHNIQUE SAS**  
 2, Rue de l'Industrie  
 25800 VALDAHON - FRANCE  
 Tél: 33 (0) 3 81 56 78 00  
 Fax: 33 (0) 3 81 56 78 03  
 Email: tt.microtechnique@technotime.com

**TECHNOTIME  
 ASIA LTD**  
 21st floor Lee Fund Centre,  
 31 Wong Chuk Hang Road  
 Aberdeen - HONG KONG  
 Tél: (852) 25551879  
 Fax: (852) 25544359  
 Email: tt.asia@technotime.com

**CADRAN DIAL ZIFFREBLATT**

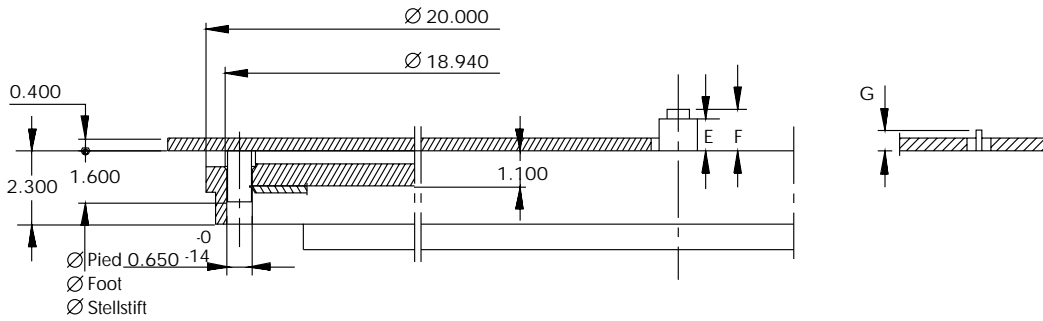

N° aiguillage	E	F	G
1	1.000	1.300	0.650

