



# technotime

© UP DATE 01.01.03 / PAGE 1

## 71220 B



H = 3,43 mm

10 1/2"  
ø 23,3 mm

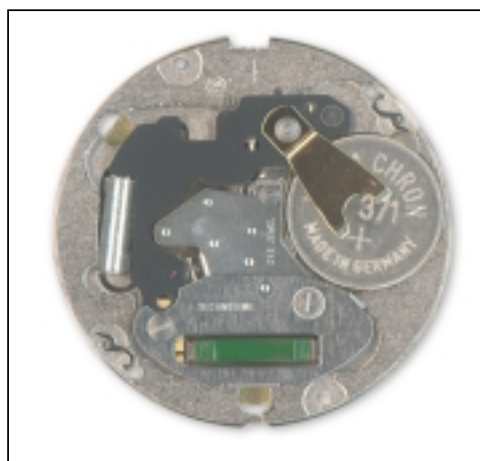

### CARACTERISTIQUES BTECHNIQUES

#### Cage

Diamètre total  
Diamètre encageage

Hauteur sur filet  
Hauteur sur tige  
Hauteur mouvement  
Hauteur totale

#### Tige de mise à l'heure

Diamètre du filetage

#### Résonateur

Fréquence

#### Moteur

Nombre d'impulsions  
par minute

#### Execution:

Swiss made: 7 rubis  
french parts: 1 rubis

#### Finition:

Swiss made: doré  
french parts: nickelé

### TECHNICAL DATA

#### Frame

Overall diameter  
Casing diameter

Height at bead  
Height at stem  
Movement height  
Total height

#### Hand-setting stem

Threading diameter

#### Resonator

Frequency

#### Motor

Number of impulses p/minute

#### Version:

Swiss made: 7 jewels  
Version: 1 jewel

#### Finishing:

Swiss made: gold plated  
Version: nickel plated

### TECHNISCHE DATEN

#### Gestell

Gesamte-Durchmesser  
Durchmesser zur Gehäuse-  
Passung

Höhe am Wulst  
Höhe an der Welle  
Werkhöhe  
Gesamte Höhe

#### Stellwelle

Gewindedurchmesser

#### Resonator

Frequenz

#### Motor

Impulszahl p/Minute

#### Ausführung:

Swiss made: 7 Steine  
Ausführung: 1 Stein

#### Ausführung:

Swiss made: vergoldet  
Ausführung: vernicklet

### 71220 B

23,900mm  
23,300mm

1,530mm  
1,930mm  
3,430mm  
3,530mm

0,900mm

32 768 Hz

60

  
**technotime**  
www.technotime.com

### TECHNOTIME SA

Site Dubied 10  
2108 COUVET - SUISSE  
Tél: +41 (0) 32 864 90 10  
Fax: +41 (0) 32 864 90 19  
Email: tt@technotime.com

### TECHNOTIME MICROTECHNIQUE SAS

2, Rue de l'Industrie  
25800 VALDAHON - FRANCE  
Tél: 33 (0) 3 81 56 78 00  
Fax: 33 (0) 3 81 56 78 03  
Email: tt.microtechnique@technotime.com

### TECHNOTIME ASIA LTD

21st floor Lee Fund Centre,  
31 Wong Chuk Hang Road  
Aberdeen - HONG KONG  
Tél: (852) 25551879  
Fax: (852) 25544359  
Email: tt.asia@technotime.com

# 71220 B



10 1/2'''  
 ø 23,3 mm  
 H = 3,43 mm

© UP DATE 01.01.03 / PAGE 2

## CONTRÔLES TESTS KONTROLLEN

Position Position Messpunkt	Echelle de mesure Measuring range Messbereich	Mesure Measurement Messung	Contrôle Test Kontrolle	Remarques Remarks Bemerkungen
1	2 V	1,55 V	Tension de la pile Battery voltage Spannung der Batterie	
2	2 V	Le mouvement doit fonctionner sous 1,35 V The movement must be running under 1,35 V Das Werk musse unter 1,35 V Spannung laufen	Limite inférieure de la tension de fonctionnement Lower working voltage limit  Untere Funktionsspannungsgrenze	Pile enlevée Vis de bride serrée Alimentation extérieure
	10 µA · 1,55 V	0,6 µA ≤   ≤ 1,4 µA	Consommation du mouvement Consumption of movement Stromverbrauch vom Werke	Remoted battery Tightened bridle screw Outside power supply
	10 µA · 1,55 V	0,1 µA ≤   ≤ 0,4 µA	Consommation en fonction stop Tige en position 3 Consumption in stop position Handsetting stem in position 3 Stromverbrauch in Stop-Stellung Stellwelle in Stellung 3	Entfernte Batterie Angezogene Bügelschraube Speizegerät
3	Ω · 0,2 V maxi	1200 Ω < R < 1400 Ω	Résistance de la bobine Resistance of coil Widerstand der Spule	Pile et écran magnétique enlevés Battery and magnetic screen removed Batterie und Machetschirm entfernt

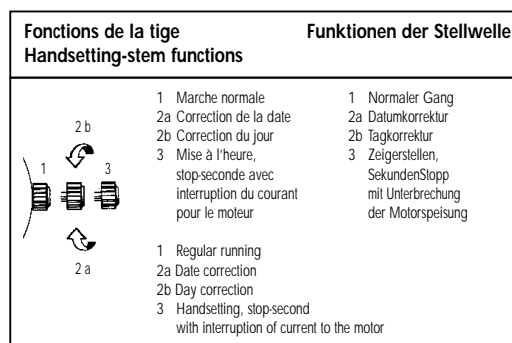
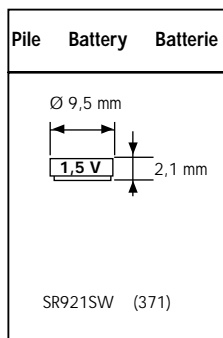
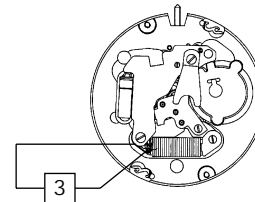
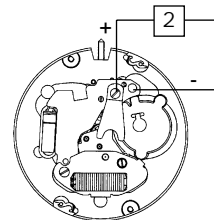
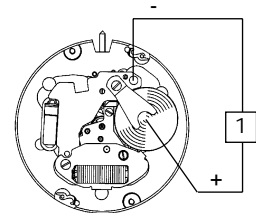

71220 B



10 1/2'''  
 ø 23,3 mm  
 H = 3,43 mm

© UP DATE 01.01.03 / PAGE 3

**AIGUILLAGE      HAND-FITTING      ZEIGERSETZEN**

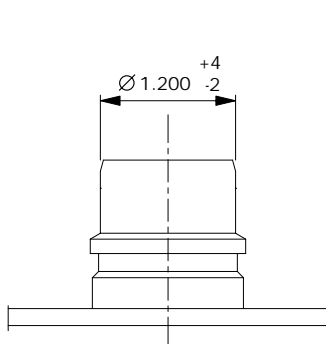

Roue des heures  
 Hour weehl  
 Stundenrad

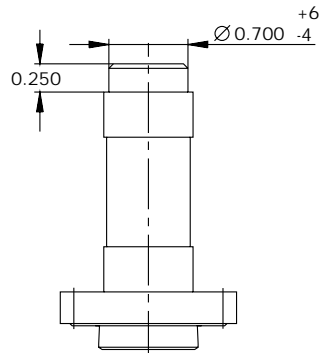

Chaussee  
 Cannon pinion  
 Minutenrohr

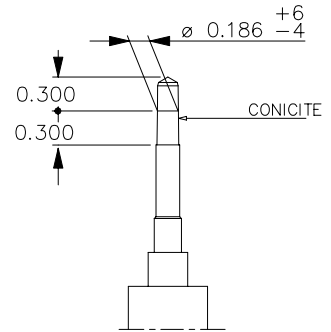

Petite seconde  
 Small second  
 Kleine Sekunde

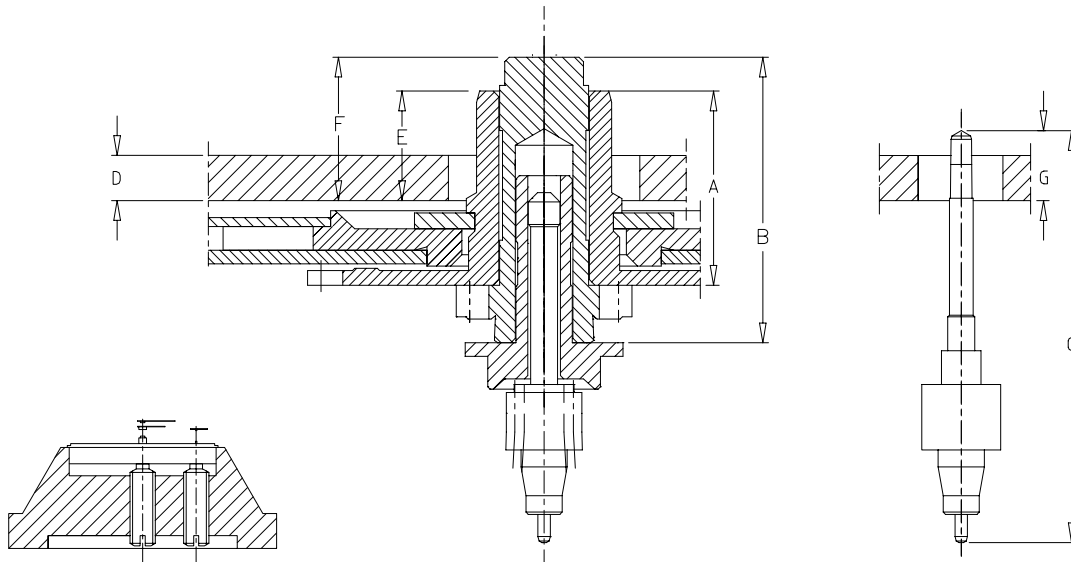

ATTENTION : CHASSAGE DES AIGUILLES, UTILISER UN PORTE-PIECES A VIS  
 NOTICE : FOR DRIVING IN OF THE HANDS USE MOVEMENT HOLDER WITH SCREW  
 ACHTUNG : ZUM EINPRESSEN VON DER ZEIGER VERWENDEN SIE EINEN WERKHALTER MIT STUETZSCHRAUBE

N° aiguillage	A	B	C	D	E	F	G
1	1.720	2.530	3.650	0.400	0.970	1.270	0.620



**TECHNOTIME SA**  
 Site Dubied 10  
 2108 COUVET - SUISSE  
 Tél: +41 (0) 32 864 90 10  
 Fax: +41 (0) 32 864 90 19  
 Email: tt@technotime.com

**TECHNOTIME  
 MICROTÉCHNIQUE SAS**  
 2, Rue de l'Industrie  
 25800 VALDAHON - FRANCE  
 Tél: 33 (0) 3 81 56 78 00  
 Fax: 33 (0) 3 81 56 78 03  
 Email: tt.microtechnique@technotime.com

**TECHNOTIME  
 ASIA LTD**  
 21st floor Lee Fund Centre,  
 31 Wong Chuk Hang Road  
 Aberdeen - HONG KONG  
 Tél: (852) 25551879  
 Fax: (852) 25544359  
 Email: tt.asia@technotime.com

71220 B



10 1/2'''  
∅ 23,3 mm  
H = 3,43 mm

© UP DATE 01.01.03 / PAGE 4

## AIGUILLES HANDS ZEIGER

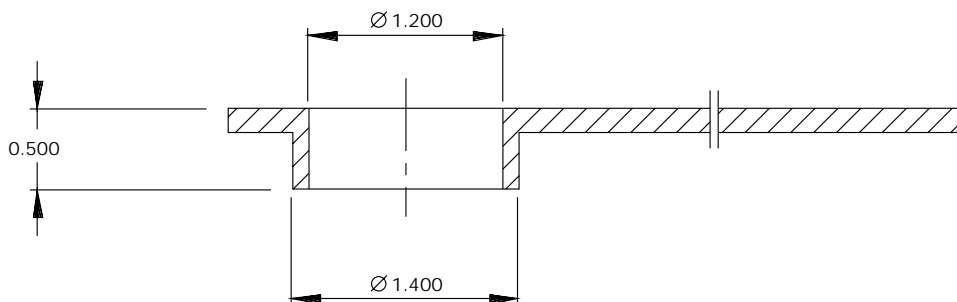
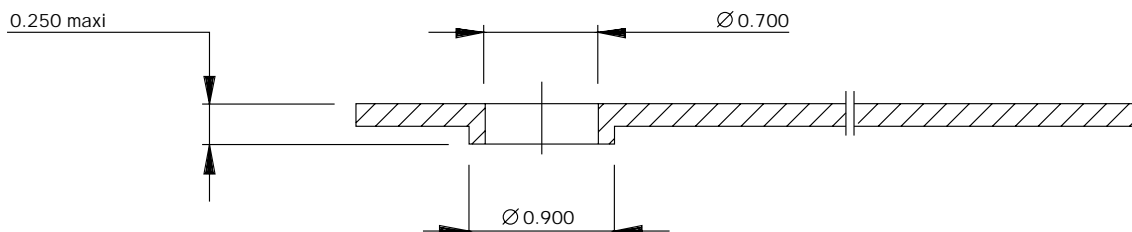
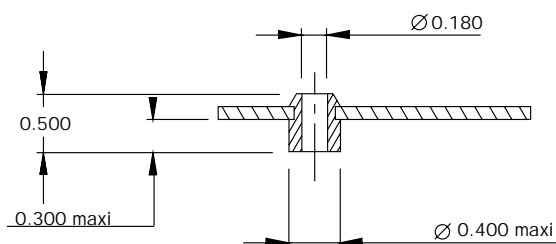

### TECHNOTIME SA

Site Dubied 10  
2108 COUVET - SUISSE  
Tél: +41 (0) 32 864 90 10  
Fax: +41 (0) 32 864 90 19  
Email: tt@technotime.com

### TECHNOTIME MICROTECHNIQUE SAS

2, Rue de l'Industrie  
25800 VALDAHON - FRANCE  
Tél: 33 (0) 3 81 56 78 00  
Fax: 33 (0) 3 81 56 78 03  
Email: tt.microtechnique@technotime.com

### TECHNOTIME ASIA LTD

21st floor Lee Fund Centre,  
31 Wong Chuk Hang Road  
Aberdeen - HONG KONG  
Tél: (852) 25551879  
Fax: (852) 25544359  
Email: tt.asia@technotime.com

71220 B



10 1/2"  
 ∅ 23,3 mm  
 H = 3,43 mm

© UP DATE 01.01.03 / PAGE 5

EMBOÎTAGE CASING EINSCHALEN

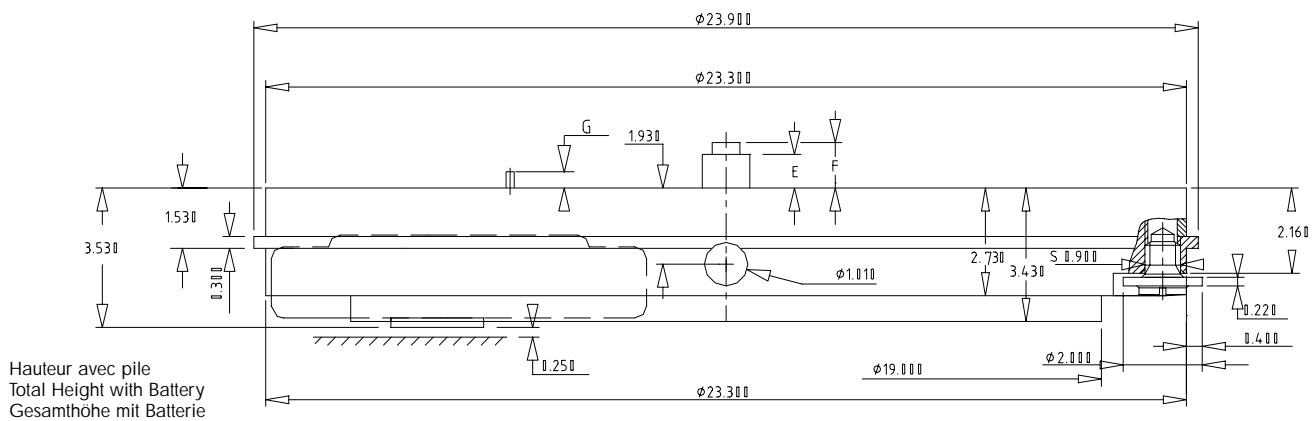

Hauteur avec pile  
 Total Height with Battery  
 Gesamthöhe mit Batterie

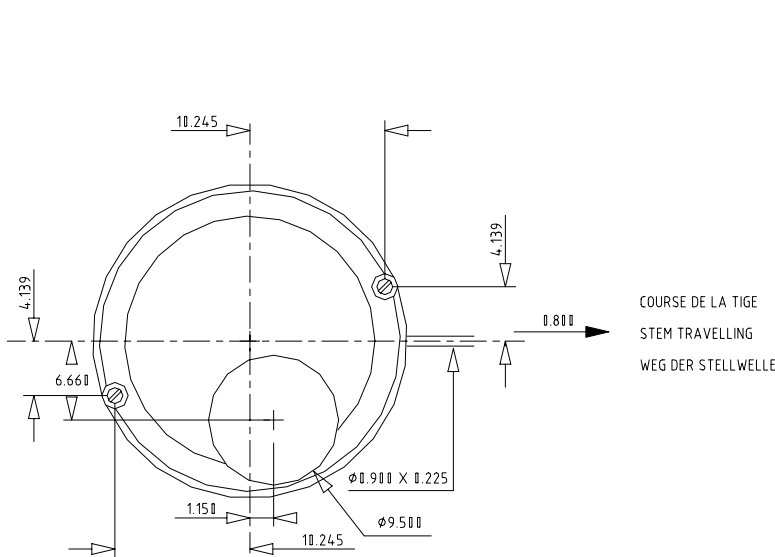

COURSE DE LA TIGE  
 STEM TRAVELLING  
 WEG DER STELLWELLE

N° aiguillage	E	F	G
1	0.970	1.270	0.620



**TECHNOTIME SA**  
 Site Dubied 10  
 2108 COUVET - SUISSE  
 Tél: +41 (0) 32 864 90 10  
 Fax: +41 (0) 32 864 90 19  
 Email: tt@technotime.com

**TECHNOTIME  
 MICROTECHNIQUE SAS**  
 2, Rue de l'Industrie  
 25800 VALDAHON - FRANCE  
 Tél: 33 (0) 3 81 56 78 00  
 Fax: 33 (0) 3 81 56 78 03  
 Email: tt.microtechnique@technotime.com

**TECHNOTIME  
 ASIA LTD**  
 21st floor Lee Fund Centre,  
 31 Wong Chuk Hang Road  
 Aberdeen - HONG KONG  
 Tél: (852) 25551879  
 Fax: (852) 25544359  
 Email: tt.asia@technotime.com

# 71220 B



10 1/2"  
Ø 23,3 mm  
H = 3,43 mm

© UP DATE 01.01.03 / PAGE 6

## CADRAN DIAL ZIFFERBLATT

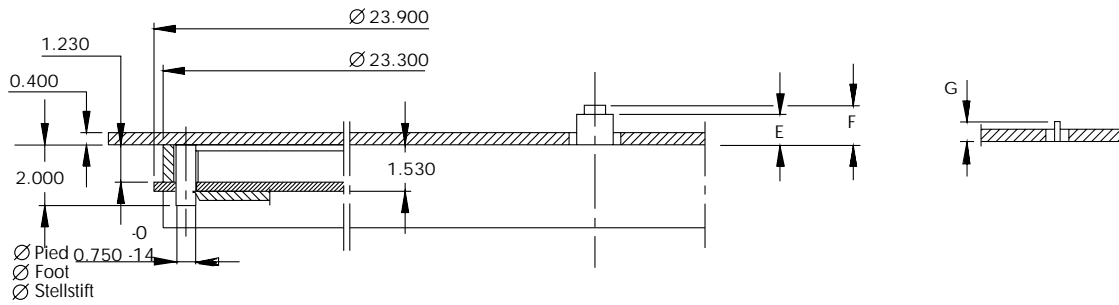

N° aiguillage	E	F	G
1	0.970	1.270	0.620

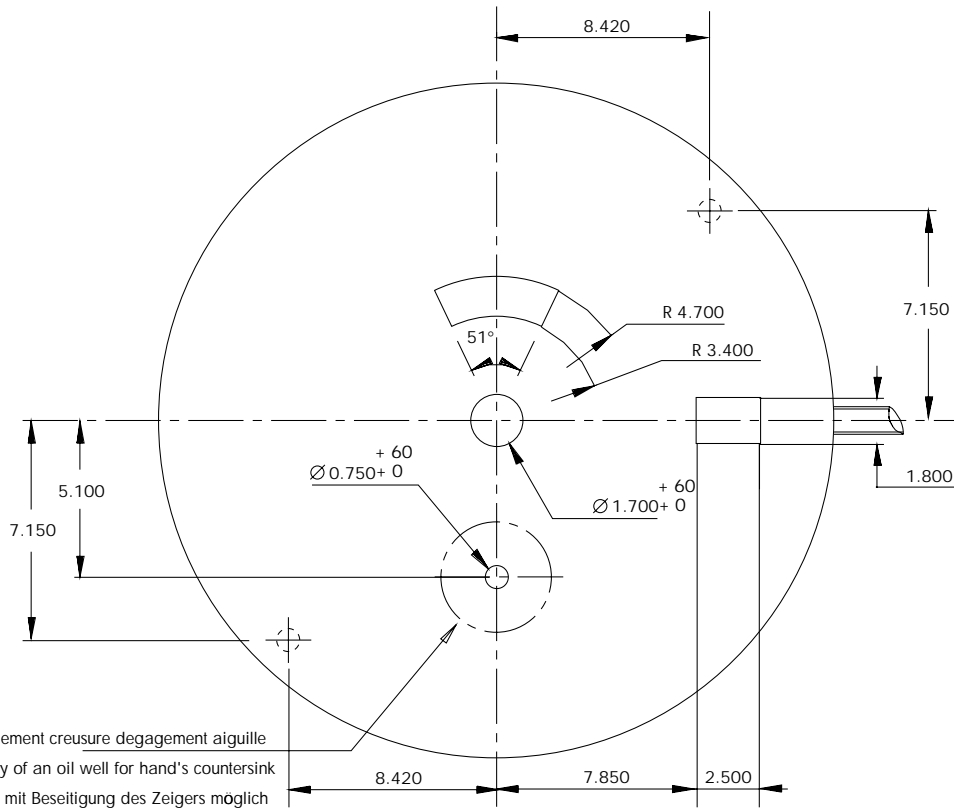

**technotime**  
www.technotime.com

### TECHNOTIME SA

Site Dubied 10  
2108 COUVET - SUISSE  
Tél: +41 (0) 32 864 90 10  
Fax: +41 (0) 32 864 90 19  
Email: tt@technotime.com

### TECHNOTIME MICROTECHNIQUE SAS

2, Rue de l'Industrie  
25800 VALDAHON - FRANCE  
Tél: 33 (0) 3 81 56 78 00  
Fax: 33 (0) 3 81 56 78 03  
Email: tt.microtechnique@technotime.com

### TECHNOTIME ASIA LTD

21st floor Lee Fund Centre,  
31 Wong Chuk Hang Road  
Aberdeen - HONG KONG  
Tél: (852) 25551879  
Fax: (852) 25544359  
Email: tt.asia@technotime.com