

IDENTIFICATION OF CHRONOGRAPH



13L



VALJOUX
CAL. 77
MINUTE REGISTER

INSTRUCTIONS

For use of book

DISASSEMBLY OF THE CHRONOGRAPH MECHANISM:

1. Study the isometric drawing at top of page 1-A. The isometric drawing was made for the following purposes:
 - A. It helps to identify the part to be removed.
 - B. This drawing aids in pointing out certain locations on the part that are mentioned in the oiling procedure.
 - C. The text refers to certain points on the part. These points are shown in the isometric drawing. This should aid you in finding the exact location on the part that is described in the text.
 - D. It helps you to determine the shape of the part in case a new part has to be made.
 - E. When disassembling the chronograph, each part should be carefully examined as it is removed from the movement. Each part should be checked against the isometric drawings to see that the part is the correct shape and is not broken. Each part should also be checked for any pits of rust, roughness, or burrs and for worn parts which may cause the part not to work properly.
2. At the bottom of the page 1-A is a photograph of a chronograph. In this photograph is the same part painted in black. The part is in the exact location that this part occupies in the watch. Find this location in the watch.
3. Read the disassembly procedure and the hazards in disassembly on page 1 in this book.
4. Remove this part in the same procedure as described in the text.
5. A very important item in disassembling a chronograph is keeping the screws in order, much time will be lost in putting the chronograph together if screws are mixed up. This means you have to hunt for each screw, sometimes trying three or four screws before finding the correct one. It cannot be stressed too strongly that care should be taken so that screws are not mixed up. The system that we advise for beginners, is to replace each individual screw after each part is removed. This naturally eliminates the hazard of mixing up the screws and will save you much time in the end. Do this at least until you become so thoroughly familiar with the chronograph that you no longer feel it is necessary.
6. Continue to follow this procedure throughout the book, and disassemble each part until the last part of the chronograph is removed.

ASSEMBLY OF THE CHRONOGRAPH MECHANISM:

7. When you are ready to assemble the chronograph mechanism, study the isometric drawing on the last part in this book. This drawing should aid you in identifying the part to be assembled and detecting possible defects on the part.
8. At the bottom of this page is a photograph of a chronograph. In this photograph is the same part painted in black. The part is shown in the exact location it occupies in the watch. (Continued on next page)

INSTRUCTIONS (Continued)

9. After you find the correct location for this part in the watch, read the oiling procedure for this part. The oiling procedure for this part is located underneath the isometric drawing. It is best to read the oiling procedure before you put each part in place, as there are certain parts that must be oiled immediately, as it may prove difficult to oil them later.

10. Read the assembly procedure and the hazards in assembling for the last part in this book.

11. Replace the part in its exact location, as shown in photograph, using the procedure as described in the text.

12. Replace the screw that holds this part in place. Of course, the screws should be kept in order as we advised above, but if the screws are not in order or the watch was received with screws mixed up, you will find a screw drawn for each part that requires a screw, at the bottom of the text page.

13. After replacing this part, replace the next part, etc., until the last part is replaced, which will be part No. 1. For replacing each part, use the procedure as described in the text.

(Note: the assembly of the chronograph is exactly the reverse of the disassembly.)

14. After the chronograph mechanism is assembled, read the functions of the different parts in the mechanism. This should help you to understand more fully the purpose of each part and how it works in conjunction with the other parts. It is to your advantage also to read the function before assembling each part, as many mistakes can be prevented when the assembling is done with an understanding of the function.

15. Read the text on adjustment of eccentric studs. This text should be read with reference to the eccentric stud picture. Now adjust each eccentric stud, one at a time, in the watch, as described in the text. Use the picture to find the position of these studs.

16. Study the text on functional results in this book, and check the chronograph mechanism as described in this text.

NOMENCLATURE OF PARTS FOR CHRONOGRAPH MECHANISM

17. After you have become thoroughly familiar with the chronograph mechanism you can disassemble and assemble the chronograph by using the nomenclature of parts as a guide. This makes it possible for you to use a procedure without going through each page in the book.

18. On each page in this book, the part number and the page number are the same. This makes it convenient for the reader and eliminates any confusion.

NOMENCLATURE OF PARTS FOR CHRONOGRAPH MECHANISM

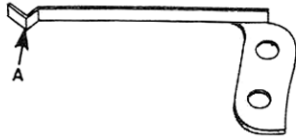

Minute Register Pawl
Assembly No. 1

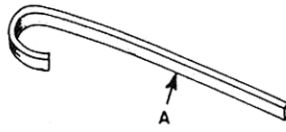

Actuating Push Piece Spring
Assembly No. 2

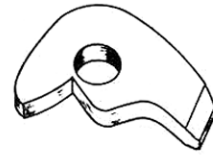

Actuating Push Piece
Assembly No. 3

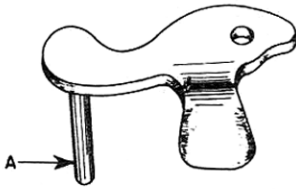

Connecting Push Piece
Assembly No. 4

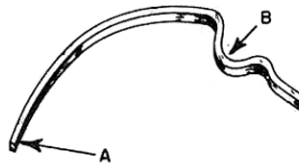

Flyback Lever Spring
Assembly No. 5

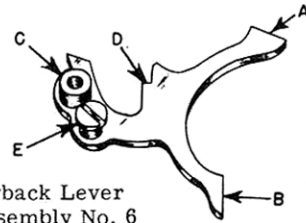

Flyback Lever
Assembly No. 6

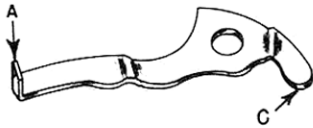

Flyback Trip Lever
Assembly No. 7



Flyback Trip Lever Spring
Assembly No. 8



Chronograph Pivoted Detent
Spring Assembly No. 9

Chronograph Pivoted Detent
and Washer

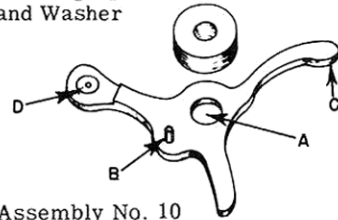

Assembly No. 10

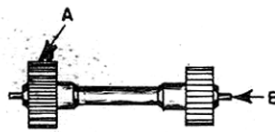

Double Intermediate Pinion
Assembly No. 11

Connecting Lever and Washer
Assembly No. 12

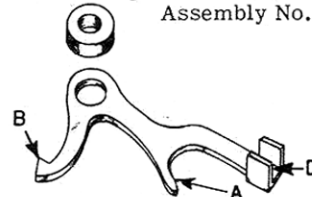

Connecting Lever Spring
Assembly No. 13

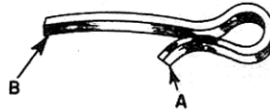

Push Piece for Setting Back to
Zero Spring Assembly No. 14



Push Piece for
Setting Back to
Zero
Assembly No. 15

NOMENCLATURE OF PARTS FOR CHRONOGRAPH MECHANISM

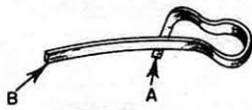

Brake Lever Spring
Assembly No. 16

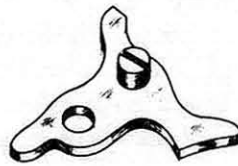

Brake Lever
Assembly No. 17

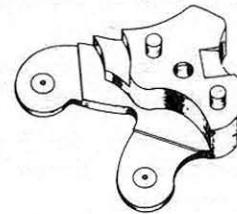

Assembly No. 18
Seconds Wheel
and Minute Register Wheel Bridge

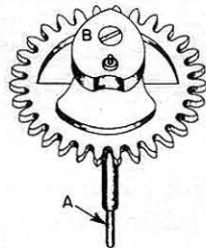

Minute Register
Wheel
Assembly No. 19

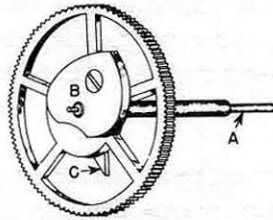

Seconds Wheel
Assembly No. 20

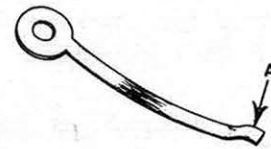

Seconds Wheel Tension Spring
Assembly No. 21

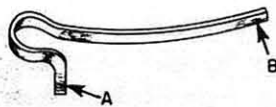

Intermittent Lever Spring
Assembly No. 22

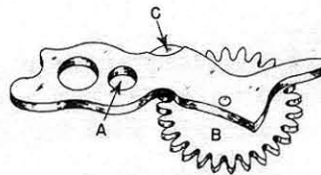

Intermittent Lever and Wheel
Assembly No. 23

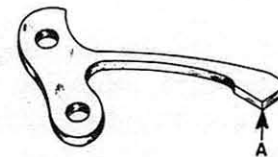

Castle Wheel Pawl
Assembly No. 24

Assembly No. 25

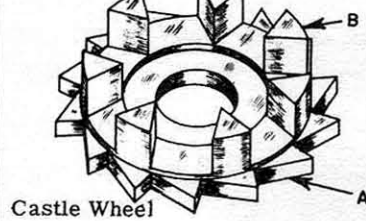

Castle Wheel

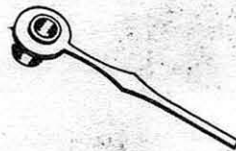

Minute Register Hand

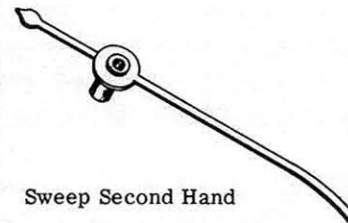

Sweep Second Hand

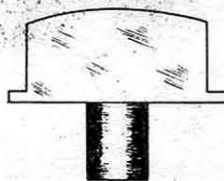

Chronograph Button

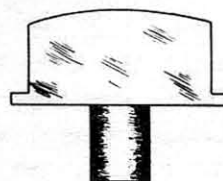

Chronograph Button

ADJUSTING ECCENTRIC STUDS

Listed below are the adjustments controlled by eccentric studs. We call them studs because they are not held in the plate like screws. The post on the lower side that is in the plate, has a smooth surface, and is held only by friction. The head of the stud is eccentric to the post so that when the stud is turned, the head will turn eccentrically. These eccentric studs should have a tight fit in their holes to prevent them from changing their position after they have been adjusted. Of course, on the other hand, the eccentric studs should not be so tight that they cannot be turned with a screwdriver.

THINGS TO CHECK

ES-1 - Check the depthing of the double intermediate pinion teeth with the seconds wheel teeth when they are engaged. If the depthing is either too deep or too shallow, the depthing can be corrected by turning the eccentric stud ES-1 slightly.

ES-2 - When engaging the chronograph to start a registration, check to see that the brake lever disengages from the seconds wheel before the double intermediate pinion engages with the seconds wheel. If the brake lever does not disengage from the seconds wheel before the double intermediate pinion engages with the seconds wheel, this can be corrected by turning eccentric stud ES-2.

ES-3 - Check the depthing of the intermittent wheel with the seconds wheel dart tooth. If this depthing is either too deep or too shallow, it can be corrected by turning eccentric stud ES-3. This adjustment also involves other factors, which to explain would go beyond the frame of this book. Therefore, we refer to the more detailed information in the Function Book, Volume 24.

ES-4 - Check the depthing of the intermittent wheel teeth with the minute register wheel teeth. If the mesh is either too deep or too shallow, it can be corrected by turning the eccentric stud ES-4. In this adjustment, there are some other factors involved, which to explain would go beyond the frame of this book. Therefore, we refer to the more detailed information in the Function Book, Volume 24.

NOTE: If ES-4 is turned 180 degrees from its correct position, (away from the center of the watch), the intermittent lever will prevent the trip lever from holding the flyback lever away from the hearts.

REFERENCE: Double intermediate pinion is Assembly 11.
Connecting lever is Assembly 12.
Brake lever is Assembly 17.
Minute register wheel is Assembly 19.
Seconds wheel is Assembly 20.
Intermittent lever and wheel assembly is Assembly 23.

ADJUSTING ECCENTRIC STUDS

DO NOT REMOVE THESE STUDS

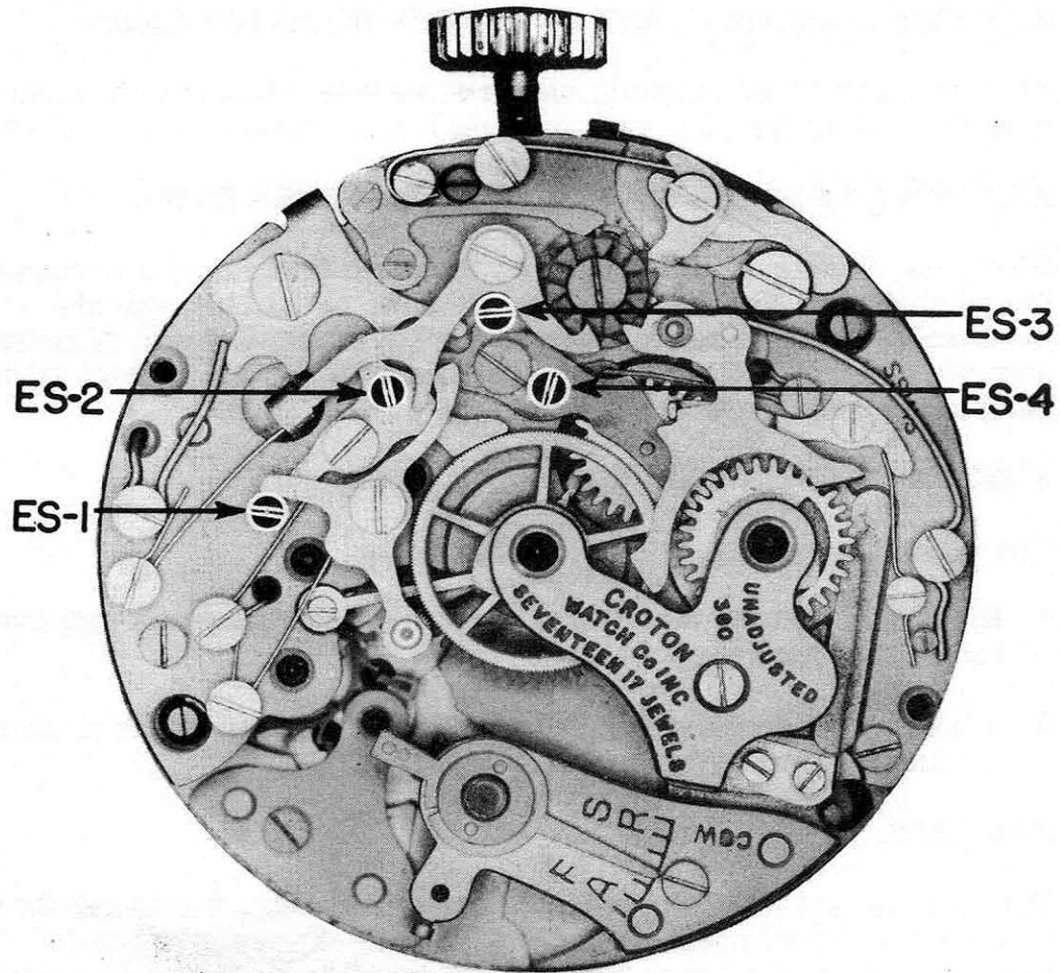

CAUTION

In disassembling or assembling a chronograph, it is a good policy not to turn eccentric studs. These eccentric studs are used to adjust one part to another, and naturally, in turning these studs you will lose the desired adjustment of the chronograph mechanism, which will cause the chronograph to function incorrectly. Another reason for not turning these studs, unless it is necessary, is that they soon become loose and will not hold the desired adjustment.

PART NO. 1

A. DISASSEMBLY PROCEDURE OF MINUTE REGISTER PAWL:

The minute register pawl is held in place by two identical fillister head screws, FS-1 and FS-2. After these screws are removed, the pawl may be lifted out of place.

(The shape of screws for this part is shown at bottom of page.)

B. HAZARDS IN DISASSEMBLY OF MINUTE REGISTER PAWL:

This part should be carefully handled, as it is thin and easily damaged. A slight bend in the pawl may prevent it from functioning properly.

C. ASSEMBLY PROCEDURE OF MINUTE REGISTER PAWL:

Place the minute register pawl on the plate in the position shown in the photograph. The two holes in the pawl should be over the proper screwholes in the plate, and the end "A" of the pawl should be centered between two teeth of the minute register wheel. Now replace fillister head screws FS-1 and FS-2 to hold the pawl in place.

D. FUNCTION OF MINUTE REGISTER PAWL:

The minute register pawl has two functions:

1. It assures that the minute register wheel turns exactly one tooth for each minute registration.
2. It holds the minute register wheel so that a bump or jar cannot alter the position of this wheel.

REMARKS:

The tension that this pawl holds on the minute register wheel should be no greater than necessary to perform its functions properly. Too great a tension will cause an unnecessary drag on the train of the watch each time a minute registration is taking place.

REFERENCE: Minute register wheel is Assembly 19.

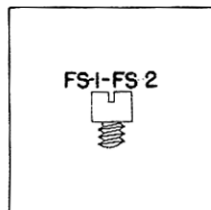

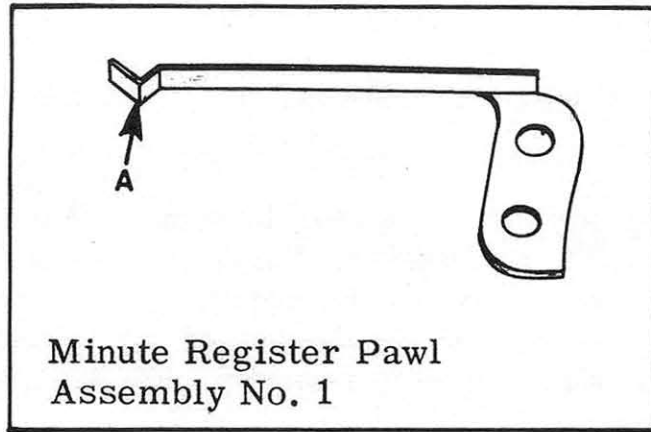

Minute Register Pawl
Assembly No. 1

OILING

The minute register pawl should not be oiled.

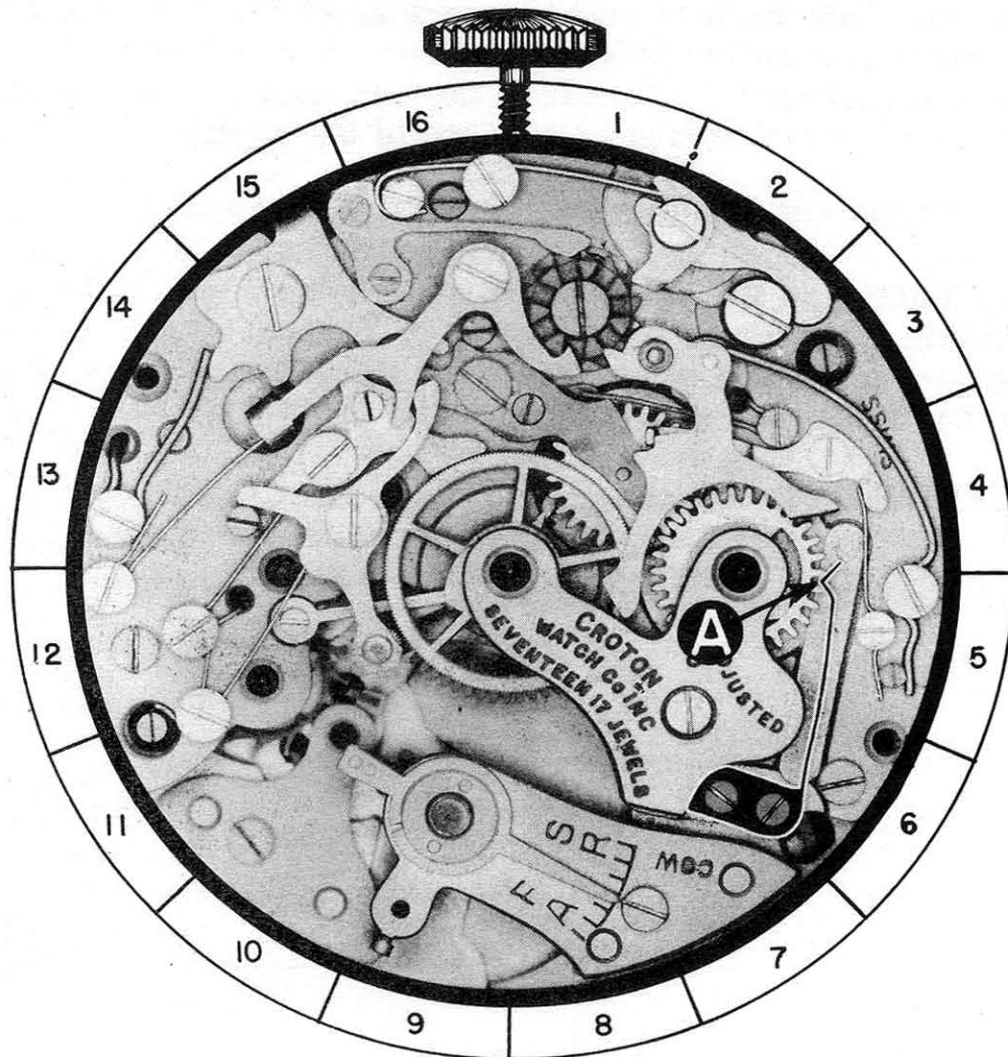

PART NO. 2

A. DISASSEMBLY PROCEDURE OF ACTUATING PUSH PIECE SPRING:

The actuating push piece spring is held in place by two shouldered screws, SS-1 and SS-2. First remove screw SS-2. This will release the tension on the spring so that the screw SS-1 can be removed without any danger of the spring shooting away. After the screws have been removed, the spring may be lifted out of place.

(The shape of screws for this part is shown at bottom of page.)

B. ASSEMBLY PROCEDURE OF ACTUATING PUSH PIECE SPRING:

Place the spring on the plate in the position shown in the photograph. Now replace shouldered screw SS-1 and then, SS-2. In order to replace shouldered screw SS-2, the actuating push piece spring must be forced in the direction so that the shoulder of the screw will not hit on top of the spring.

C. FUNCTION OF ACTUATING PUSH PIECE SPRING:

The function of the actuating push piece spring is to hold the actuating push piece in a position so that each time the actuating push piece and connecting push piece is pushed, it will turn the castle wheel.

REFERENCE: Actuating push piece is Assembly 3.
Connecting push piece is Assembly 4.
Castle wheel is Assembly 25.

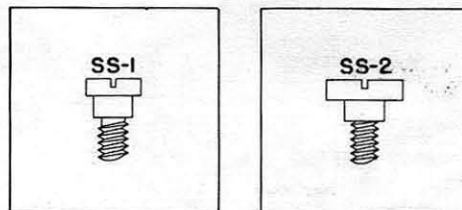

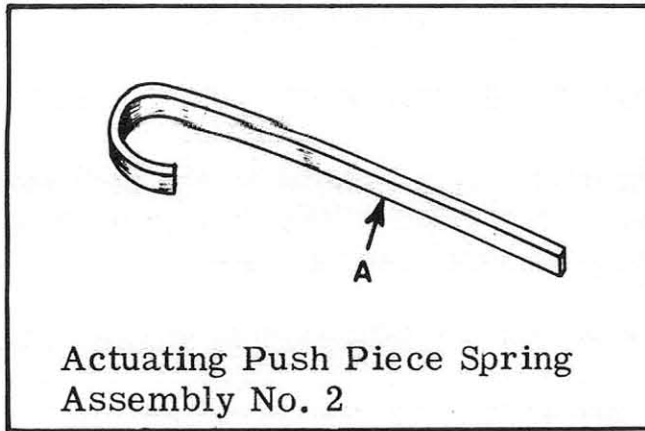

OILING

This spring should be moistened with oil at the point of contact with the actuating push piece.

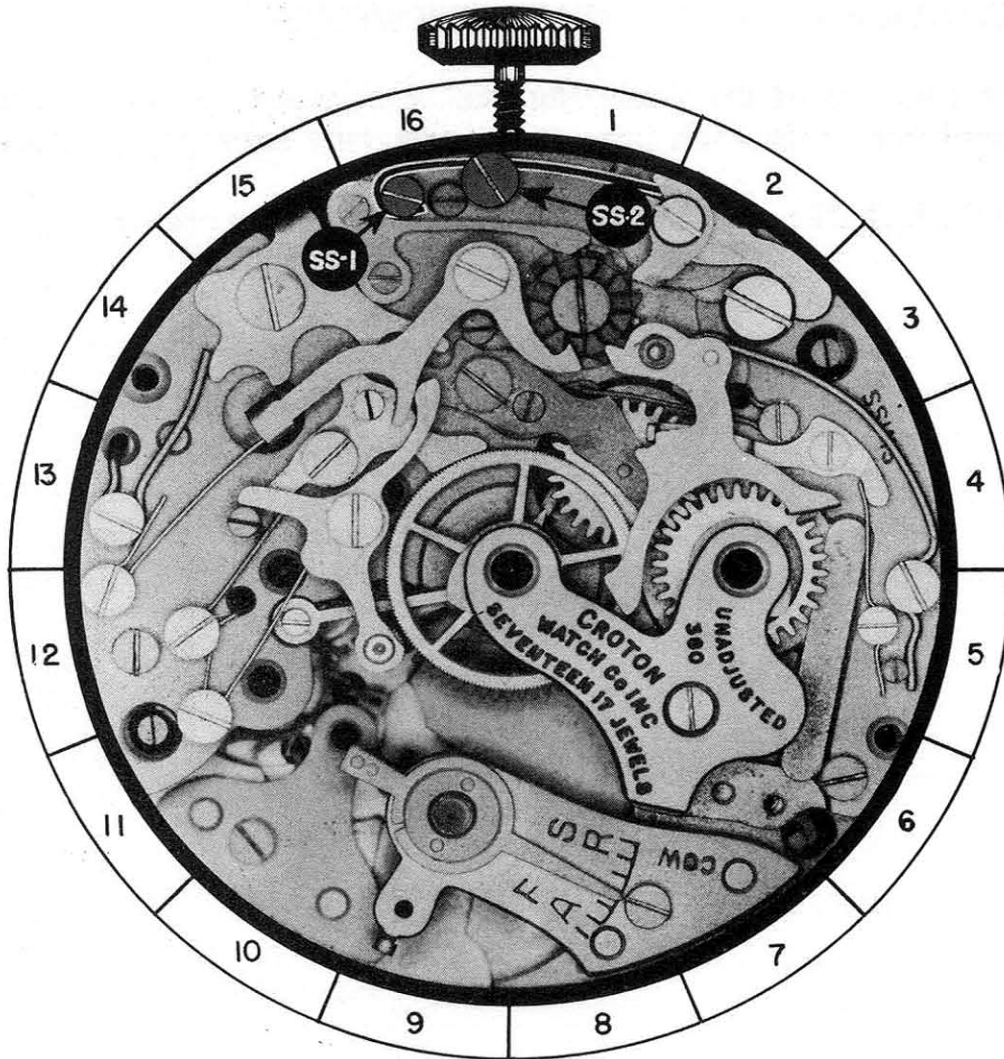

PART NO. 3

A. DISASSEMBLY PROCEDURE OF ACTUATING PUSH PIECE:

The actuating push piece is held on the connecting push piece by shouldered screw SS-3. When this screw is removed, the push piece may be lifted out of place.

(The shape of screw for this part is shown at bottom of page.)

B. ASSEMBLY PROCEDURE OF ACTUATING PUSH PIECE:

Place the actuating push piece on the connecting push piece in the position shown in the photograph. Now replace shouldered screw SS-3 to hold the actuating push piece in position and check to see that the push piece pivots freely under the head of this screw.

C. FUNCTION OF ACTUATING PUSH PIECE:

The function of the actuating push piece is to move the castle wheel one tooth each time the connecting push piece is pushed.

REFERENCE: Connecting push piece is Assembly 4.
Castle wheel is Assembly 25.

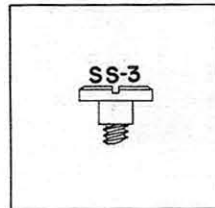

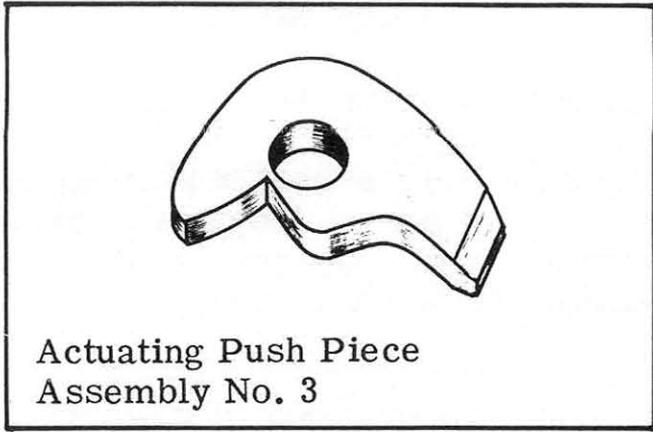

Actuating Push Piece
Assembly No. 3

OILING

The shoulder of the screw that the actuating push piece pivots on should be slightly moistened with oil.

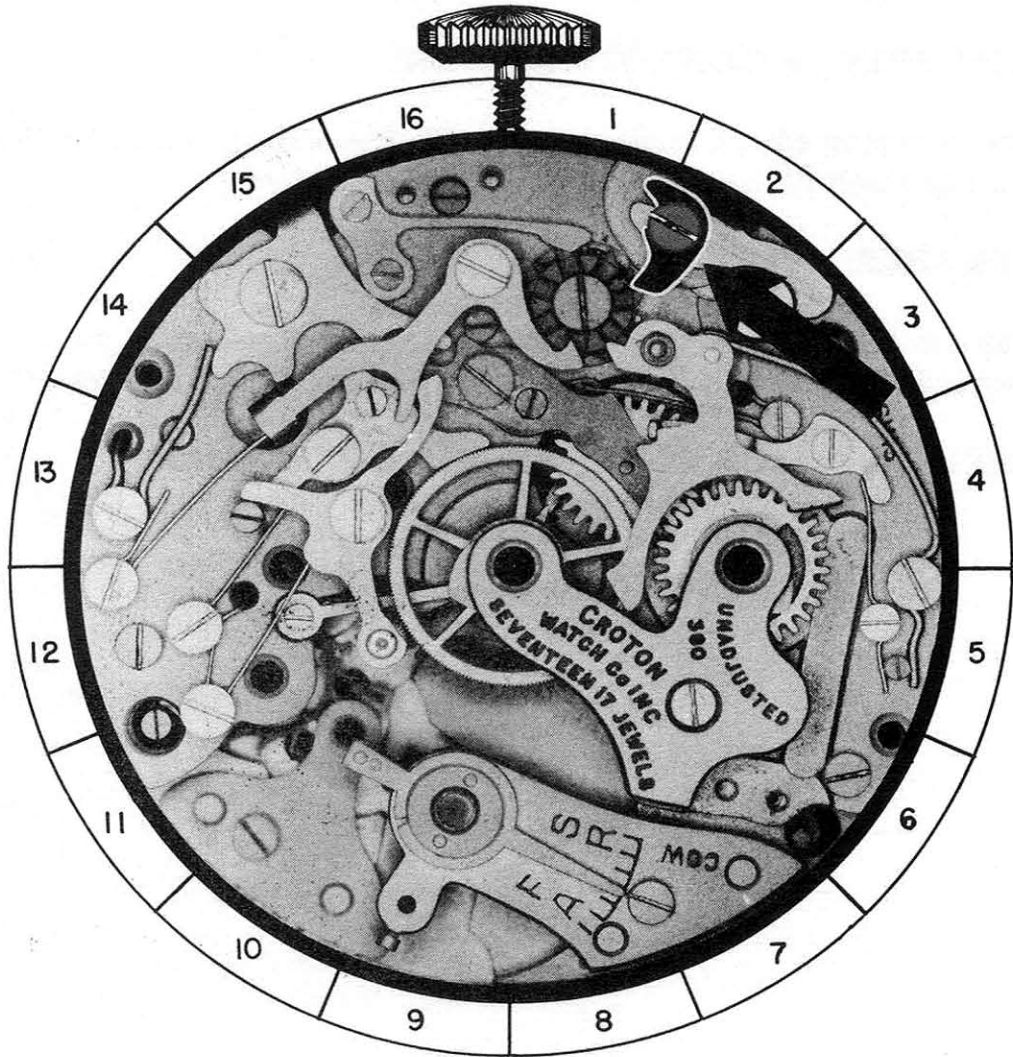

3-A

PART NO. 4

A. DISASSEMBLY PROCEDURE OF CONNECTING PUSH PIECE:

The connecting push piece is held in place by chamfered flat head screw CS-1 and a post in the push piece, which fits freely into a hole in the plate. Remove the screw and then lift the push piece straight up to lift the post "A" from the hole in the plate.

(The shape of screw for this part is shown at bottom of page.)

B. ASSEMBLY PROCEDURE OF CONNECTING PUSH PIECE:

Place the connecting push piece on the plate in the position shown in the photograph, with the post "A" in the proper hole in the plate. Now replace the screw CS-1 to hold this part in place, and check to see that the push piece pivots freely.

C. FUNCTION OF CONNECTING PUSH PIECE:

The function of the connecting push piece is to connect the actuating push piece to the chronograph button.

REMARKS:

The pin "B" in the plate serves as a stop to limit the movement of the push piece away from the center of the watch.

REFERENCE: Actuating push piece is Assembly 3.

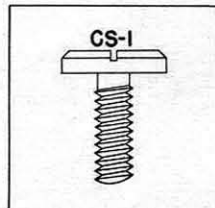

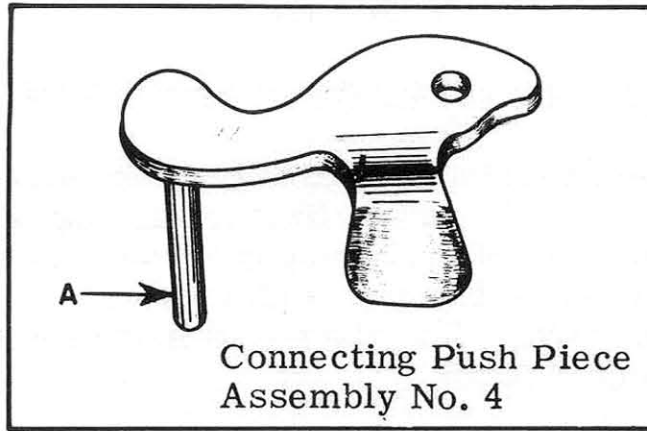

OILING

The post "A" on connecting push piece should be slightly moistened with oil.

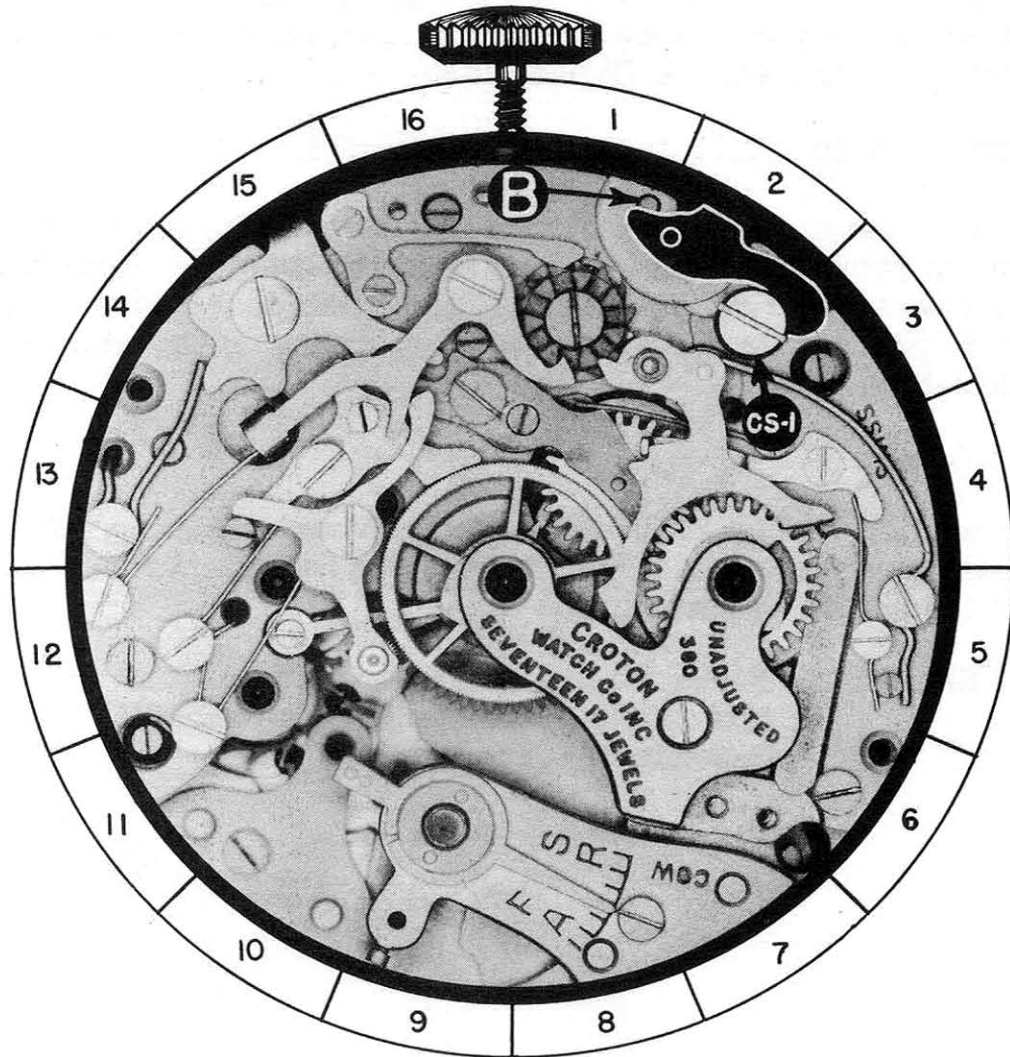

PART NO. 5

A. DISASSEMBLY PROCEDURE OF FLYBACK LEVER SPRING:

The flyback lever spring is held in place by shouldered screw SS-4. To remove this spring, first loosen the screw one turn; then lift the end "A" of the spring out from underneath the flyback lever and place it on top of this lever. This takes the tension off of the spring. Now the screw may be removed, and the spring lifted out of place.

(The shape of screw for this part is shown at bottom of page.)

B. ASSEMBLY PROCEDURE OF FLYBACK LEVER SPRING:

Place the spring on the plate with the loop "B" over the proper screw hole in the plate, and the end "A" on top of the flyback lever. Now replace shouldered screw SS-4, but before tightening this screw, move the end "A" of this spring away from the center of the watch, and place it on the shoulder of the screw located underneath the flyback lever.

C. FUNCTION OF FLYBACK LEVER SPRING:

The function of the flyback lever spring is to force the flyback lever to return the hearts on the seconds wheel and minute register wheel to a zero position. Also, it holds a downward tension to prevent the flyback lever from riding up the post on which it pivots.

REMARKS:

The tension of this spring should be strong enough to force the flyback lever to contact the hearts with sufficient force to return the hearts to zero.

REFERENCE: Flyback lever is Assembly 6.
Minute register wheel is Assembly 19.
Seconds wheel is Assembly 20.

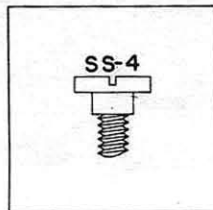

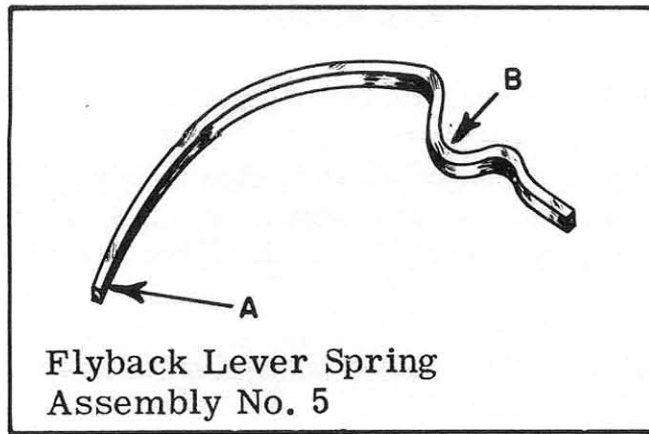

OILING

End "A" of this spring should be slightly moistened with oil at point of contact with shouldered screw on flyback lever.

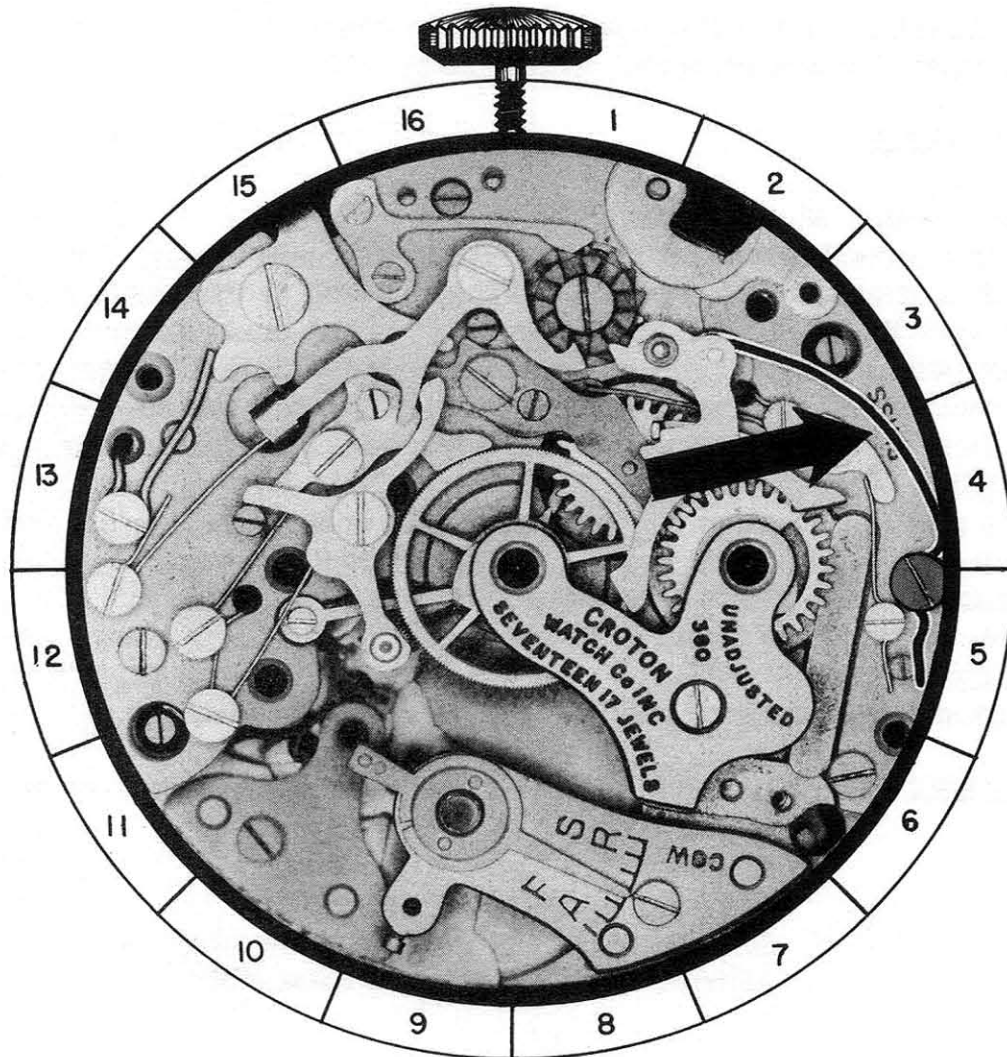

5-A

PART NO. 6

A. DISASSEMBLY PROCEDURE OF FLYBACK LEVER:

Before removing the flyback lever, check to see that it is moved from underneath the seconds wheel and minute register wheel bridge. Then grip the hub "C" of the flyback lever with tweezers and lift straight up.

B. ASSEMBLY PROCEDURE OF FLYBACK LEVER:

Place the flyback lever in position with the hole in hub "C" over the post on the plate. The screwhead "E" on the flyback lever should be down. Now move the end "A" of the flyback trip lever from underneath the flyback lever, and push the flyback lever down to the proper level.

C. FUNCTION OF FLYBACK LEVER:

The function of the flyback lever is to return the seconds wheel and minute register wheel to a zero position.

REMARKS:

The seconds wheel is returned to a zero position by the flyback lever contacting the heart "B" on the seconds wheel. The heart on this wheel is set eccentric. The flat end of the flyback lever contacts the eccentric heart, and forces the heart to turn. The heart will turn until the flat end of the flyback lever sets across the two lobes at the top of the heart. With the pressure equalized on these two lobes, it will turn no further, and this will be a zero position. If this wheel has turned less than 160 degrees from a zero position when the flyback lever is brought in contact with the heart, it will turn in the opposite direction to which it was turning, to bring this wheel back to a zero position. On the other hand, if the wheel is turned past 160 degrees from a zero position, the flyback lever will force the heart to continue to turn in the direction it was turning, until it reaches a zero position.

REFERENCE: Seconds wheel and minute register wheel bridge is Assembly 18.
Flyback trip lever is Assembly 7.
Seconds wheel is Assembly 20.
Minute register wheel is Assembly 19.
Minute register pawl is Assembly 1.

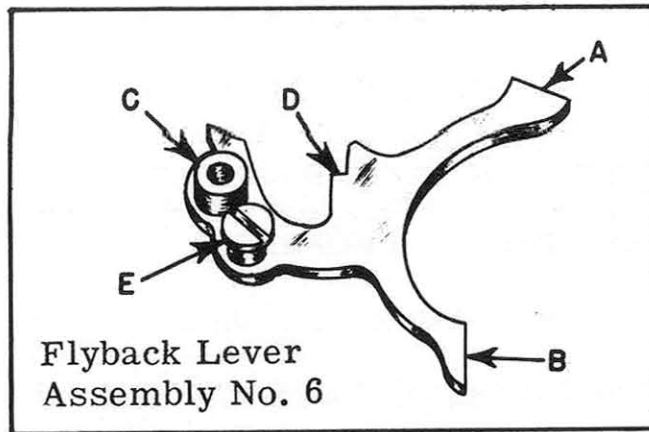

Flyback Lever
Assembly No. 6

OILING

- The following points should be slightly moistened with oil;
1. The stud that the flyback lever pivots on.
 2. Shoulder "D" on flyback lever that contacts flyback trip lever.

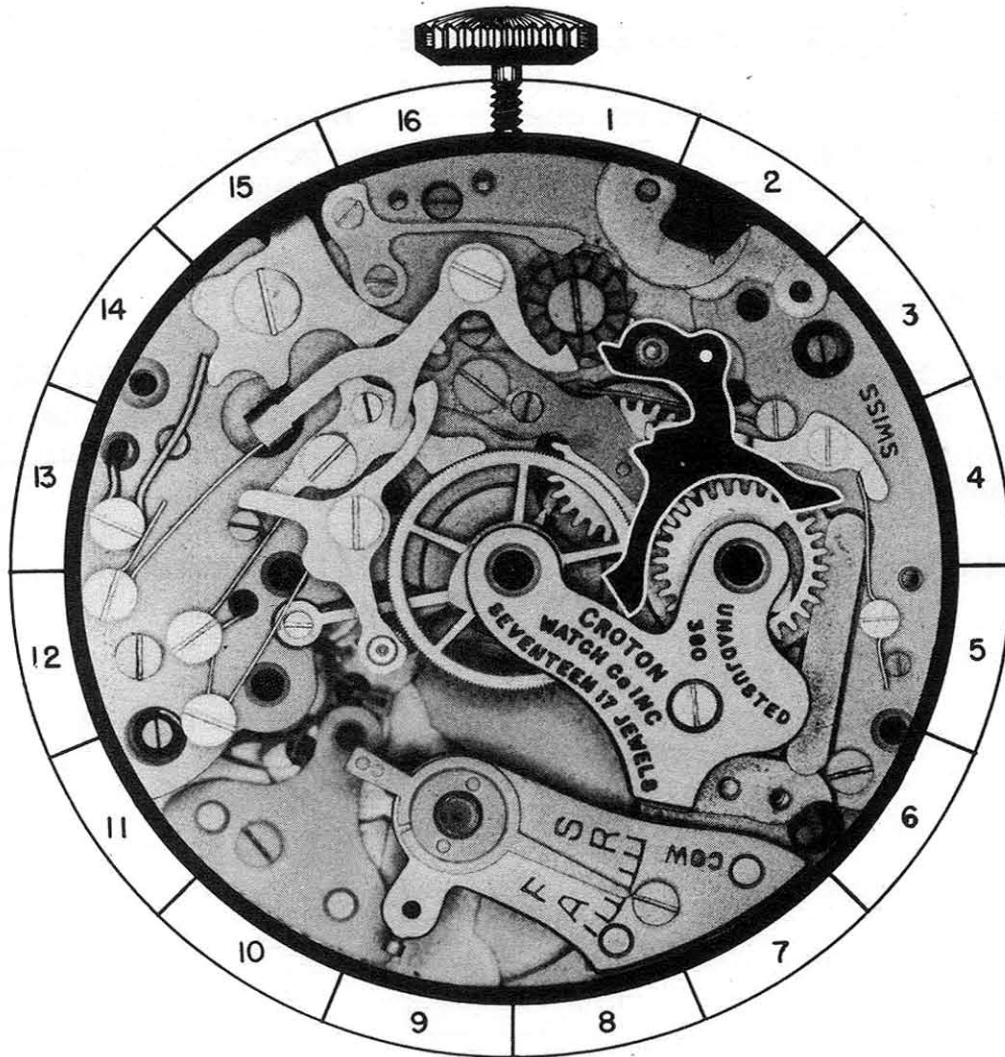

6-A

PART NO. 7

A. DISASSEMBLY PROCEDURE OF FLYBACK TRIP LEVER:

The flyback trip lever is held in place by shouldered screw SS-5, and pivots on this screw. When this screw is removed, the flyback trip lever can be lifted out of place.

(The shape of screw for this part is shown at bottom of page.)

B. ASSEMBLY PROCEDURE OF FLYBACK TRIP LEVER:

Place the flyback trip lever on the plate in the position shown in the photograph, so that the end "A" of the flyback trip lever spring is in contact with the surface "C" of the flyback trip lever. Now slide the flyback trip lever on the plate until the hole in the trip lever is over the screwhole in the plate. Hold the flyback trip lever in this position with a piece of pegwood and replace shouldered screw SS-5. The flyback trip lever should pivot freely on the shoulder of this screw.

C. FUNCTION OF FLYBACK TRIP LEVER:

The function of the flyback trip lever is to hold the flyback lever away from the hearts. However, when the button is pushed, the flyback trip lever will pivot and release the flyback lever to return the hearts to zero.

REMARKS:

The flyback trip lever in this chronograph is not controlled directly by the push piece for setting back to zero, as in other chronographs, but by the intermittent lever, which in turn is controlled by the push piece.

REFERENCE: Flyback trip lever spring is Assembly 8.
Flyback lever is Assembly 6.
Seconds wheel is Assembly 20.
Minute register wheel is Assembly 19.
Push piece for setting back to zero is Assembly 15.
Intermittent lever is Assembly 23.

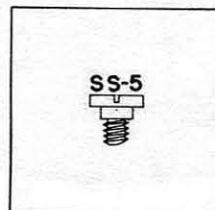

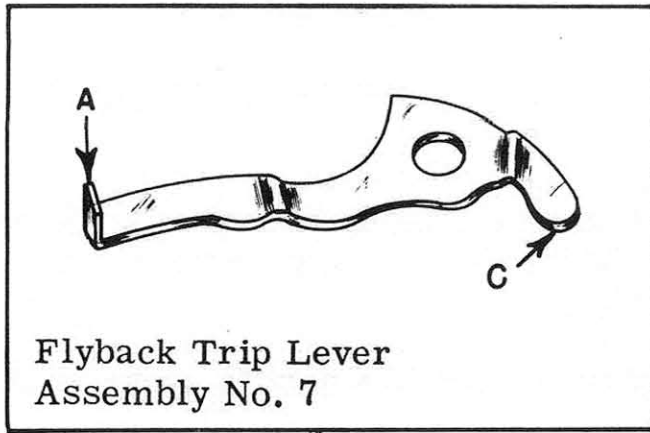

OILING

The following points should be slightly moistened with oil:

1. The shoulder of the screw that the flyback trip lever pivots on.
2. The flyback trip lever at the point of contact with the intermittent lever.
3. The end "C" of the flyback trip lever at the point of contact with the flyback trip lever spring.

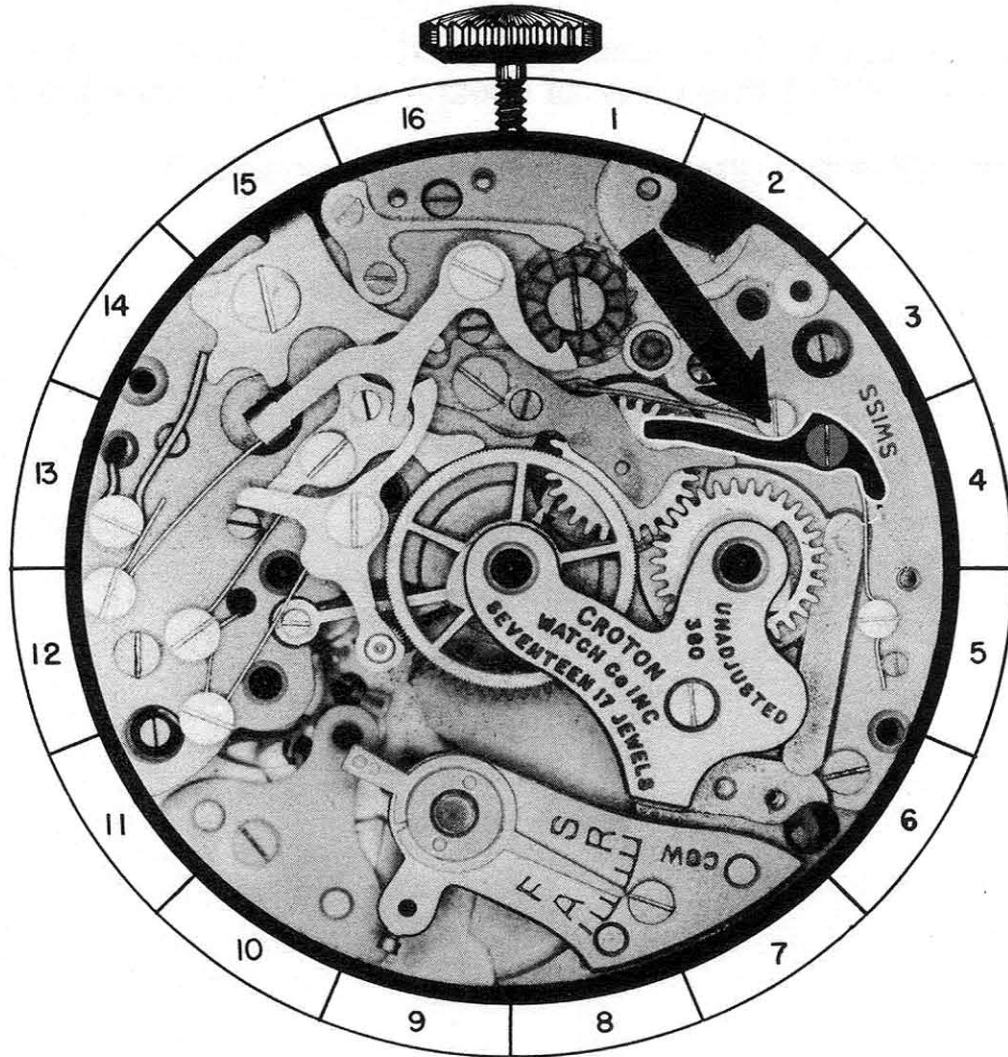

PART NO. 8

A. DISASSEMBLY PROCEDURE OF FLYBACK TRIP LEVER SPRING:

The flyback trip lever spring is held in place by shouldered screw SS-6. When this screw is removed, the spring may be lifted out of place.

(The shape of screw for this part is shown at bottom of page.)

B. ASSEMBLY PROCEDURE OF FLYBACK TRIP LEVER SPRING:

Place this spring in its proper position, as shown in the photograph, and replace shouldered screw SS-6.

C. FUNCTION OF FLYBACK TRIP LEVER SPRING:

This spring holds a tension on the flyback trip lever, keeping the end "A" of this lever in contact with the flyback lever.

REFERENCE: Flyback trip lever is Assembly 7.
Flyback lever is Assembly 6.

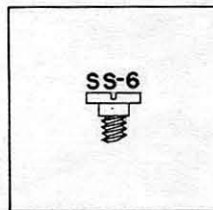

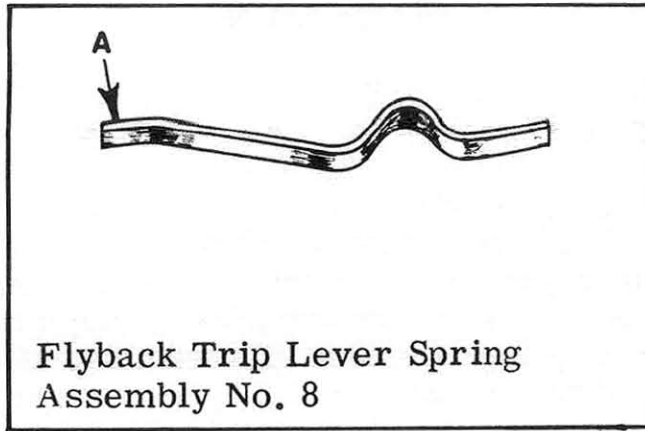

OILING

The flyback trip lever spring will be oiled after the next part is replaced.

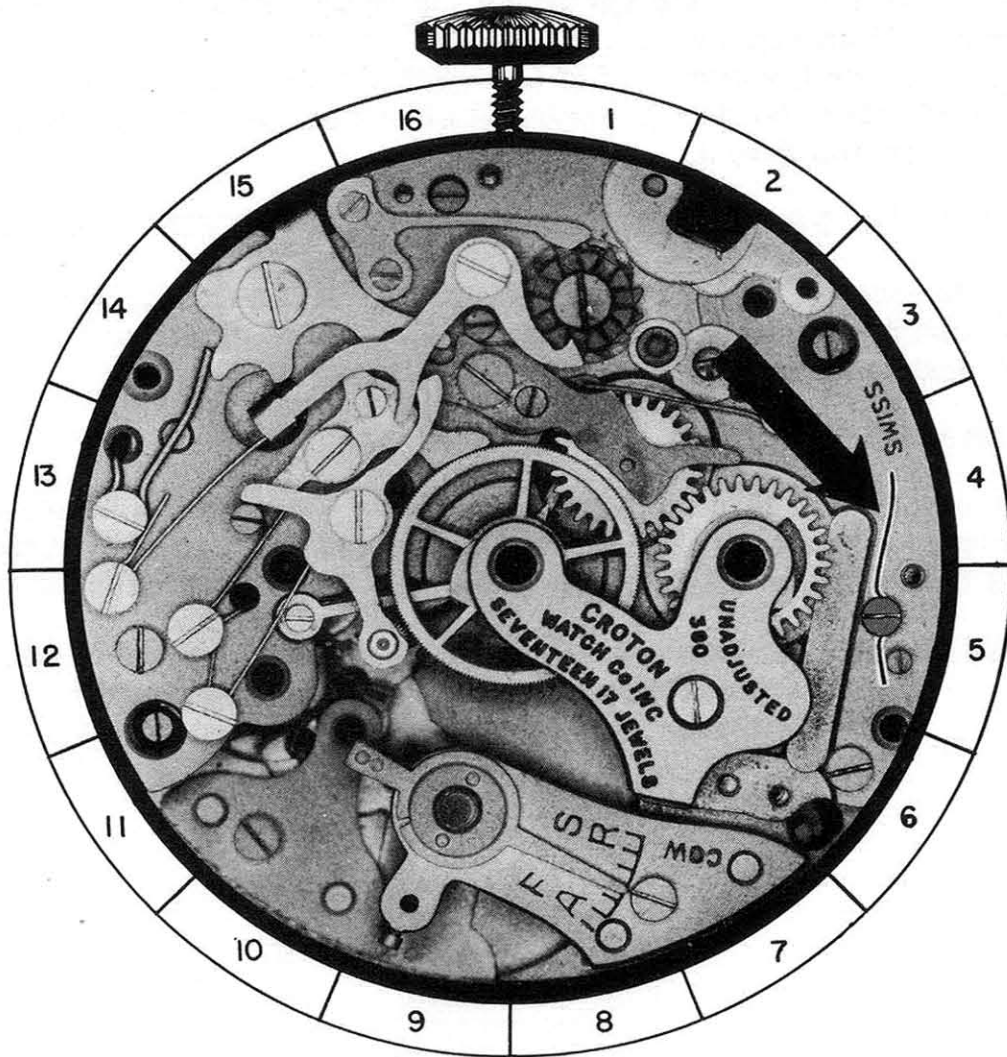

8-A

PART NO. 9

A. DISASSEMBLY PROCEDURE OF CHRONOGRAPH PIVOTED DETENT SPRING:

The chronograph pivoted detent spring is held in place by shouldered screw SS-7. When removing this screw, hold the spring with a piece of pegwood to prevent the spring from shooting away. After the screw has been removed, the spring may be lifted out of place. (This spring is easier disassembled after the chronograph pivoted detent is disassembled, but it must be assembled after the chronograph pivoted detent is assembled.)

(The shape of screw for this part is shown at bottom of page.)

B. ASSEMBLY PROCEDURE OF CHRONOGRAPH PIVOTED DETENT SPRING:

Place this spring on the plate with the loop over the screw hole, and the end "A" of the spring on top of the chronograph pivoted detent. Then replace the screw SS-7, but before tightening this screw, move the end "A" of the spring under the chronograph pivoted detent so it is pressing against pin "B" of the chronograph pivoted detent.

C. FUNCTION OF CHRONOGRAPH PIVOTED DETENT SPRING:

The function of the chronograph pivoted detent spring is to force the chronograph pivoted detent to pivot in the direction to engage the double intermediate pinion with the seconds wheel.

REMARKS:

Make sure that this spring does not hold too strong a tension on the chronograph pivoted detent, as the connecting lever spring has to overcome this tension when disengaging the chronograph.

REFERENCE: Chronograph pivoted detent is Assembly 10.
Double intermediate pinion is Assembly 11.
Connecting lever spring is Assembly 13.

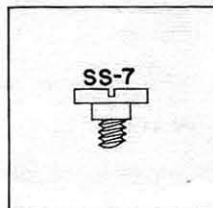

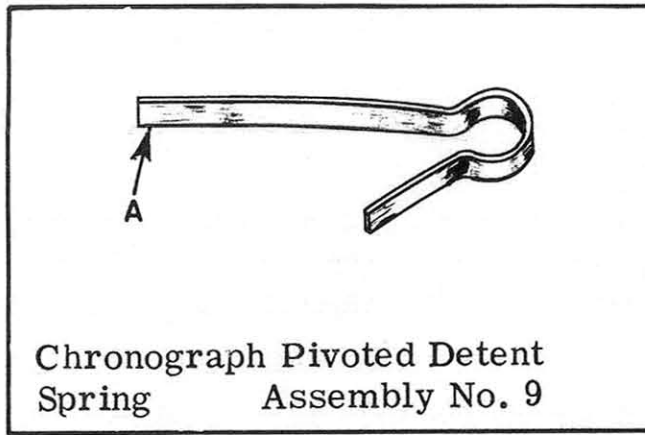

OILING

The chronograph pivoted detent spring should be slightly moistened with oil at point of contact with pin "B" on chronograph pivoted detent.

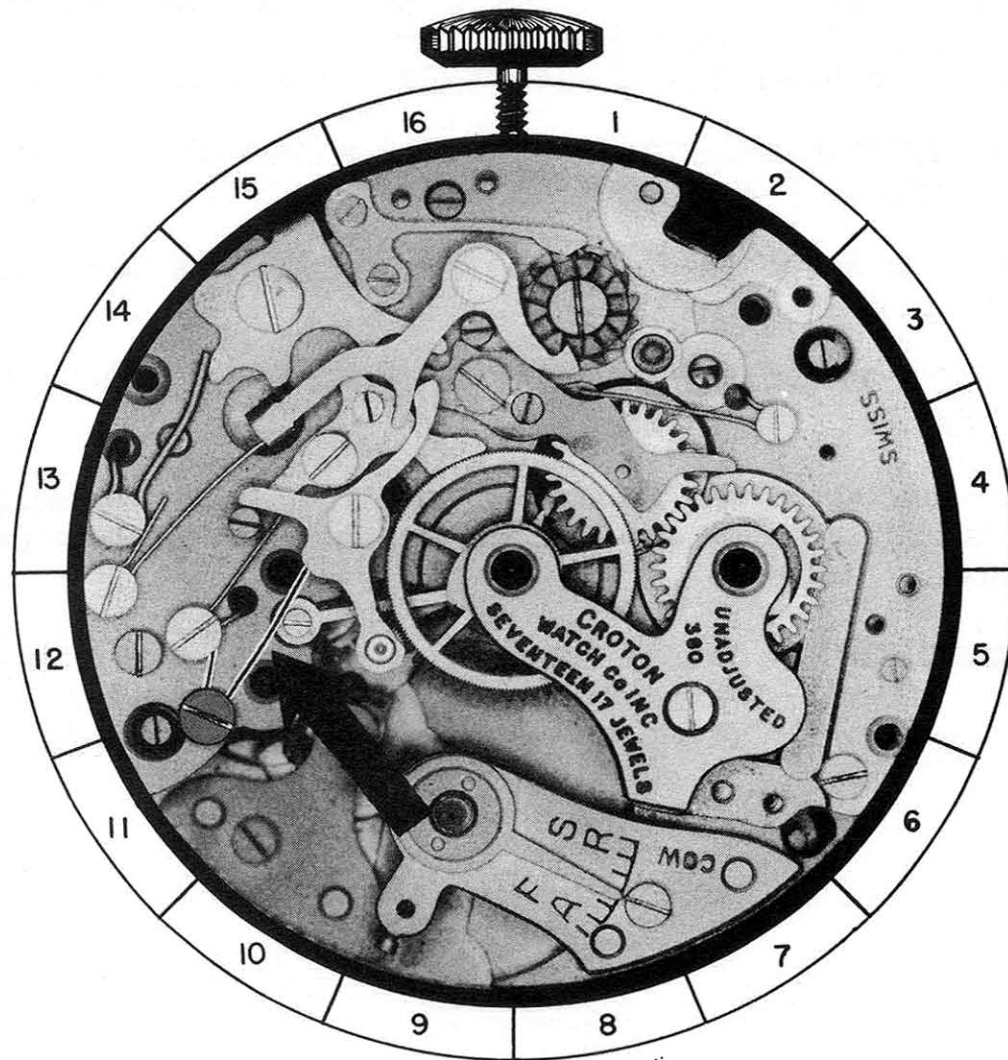

9-A

PART NO. 10

A. DISASSEMBLY PROCEDURE OF CHRONOGRAPH PIVOTED DETENT AND WASHER:

The chronograph pivoted detent is held in place by shouldered screw SS-8, and pivots on this screw. When this screw is removed, the detent and the supporting washer may be lifted out of place.

(The shape of screw for this part is shown at bottom of page.)

B. ASSEMBLY PROCEDURE OF CHRONOGRAPH PIVOTED DETENT AND WASHER:

Place the supporting brass washer centered over the proper screw hole in the plate. Then place the chronograph pivoted detent in its proper position, with the hole "A" in the detent centered over the washer, and the pivot hole over the pivot of the double intermediate pinion. Now replace the screw SS-8, and check to see that the detent pivots freely on this screw.

C. HAZARDS IN ASSEMBLY OF CHRONOGRAPH PIVOTED DETENT AND WASHER:

Check to see that the pivot has entered the pivot hole before tightening the screw.

D. FUNCTION OF CHRONOGRAPH PIVOTED DETENT AND WASHER:

The function of the chronograph pivoted detent is to engage and disengage the double intermediate pinion with the seconds wheel.

REFERENCE: Double intermediate pinion is Assembly 11.
Connecting lever is Assembly 12.
Seconds wheel is Assembly 20.

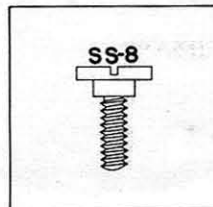

Chronograph Pivoted Detent and Washer

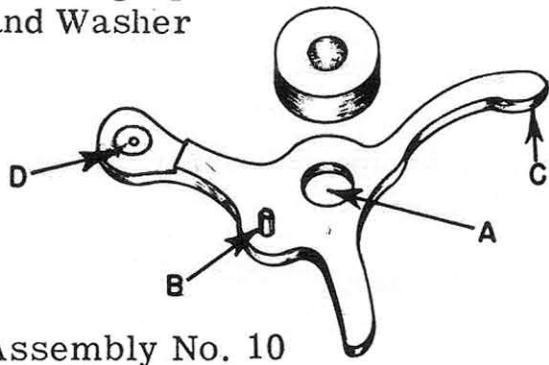

Assembly No. 10

OILING

The following points should be slightly moistened with oil:

1. The shoulder of the screw that the chronograph pivoted detent pivots on.
2. The end "C" of the chronograph pivoted detent at the point of contact with the connecting lever.

The top and bottom pivots of the double intermediate pinion should be oiled as you would properly oil a train pivot in a watch.

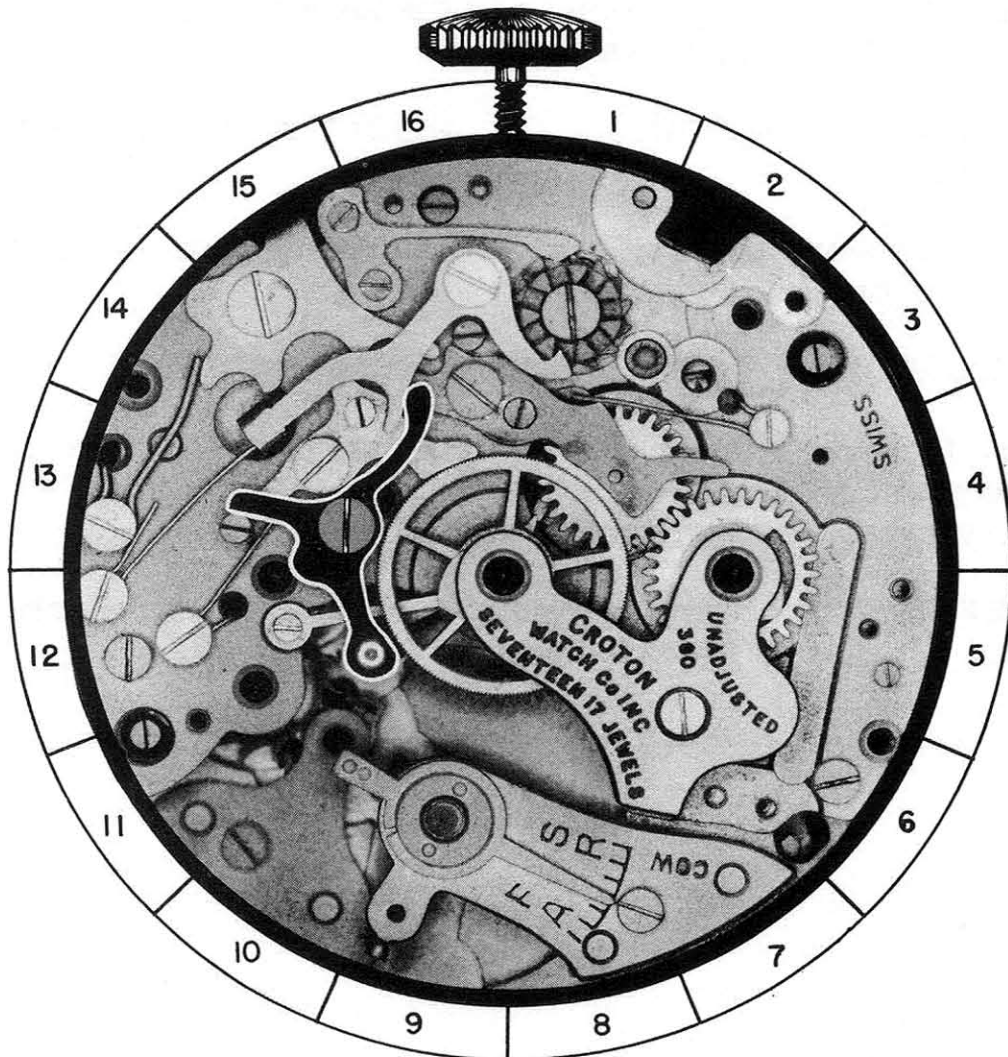

10-A

PART NO. 11

A. DISASSEMBLY PROCEDURE OF DOUBLE INTERMEDIATE PINION:

To remove the double intermediate pinion, simply lift it straight up out of place.

B. HAZARDS IN DISASSEMBLY OF DOUBLE INTERMEDIATE PINION:

Any excessive tilting of the double intermediate pinion may bend or break the pivots on this pinion.

C. ASSEMBLY PROCEDURE OF DOUBLE INTERMEDIATE PINION:

Place this pinion in its proper position, with the pivot on end "B" down in the pivot hole, and the leaves of the pinion engaged with the fourth wheel.

D. HAZARDS IN ASSEMBLY OF DOUBLE INTERMEDIATE PINION:

Any excessive tilting of the double intermediate pinion may bend or break the pivots on this pinion.

E. FUNCTION OF DOUBLE INTERMEDIATE PINION:

The function of the double intermediate pinion is to transfer the power from the fourth wheel to the seconds wheel when the chronograph is engaged.

REFERENCE: Chronograph pivoted detent is Assembly 10.
Seconds wheel is Assembly 20.

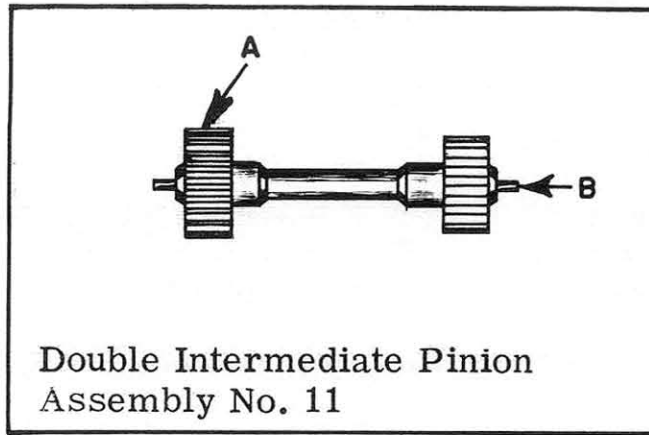

OILING

The top and bottom pivots of the double intermediate pinion should be oiled after the chronograph pivoted detent is replaced. These pivots are oiled as you would properly oil the train pivots of a watch.

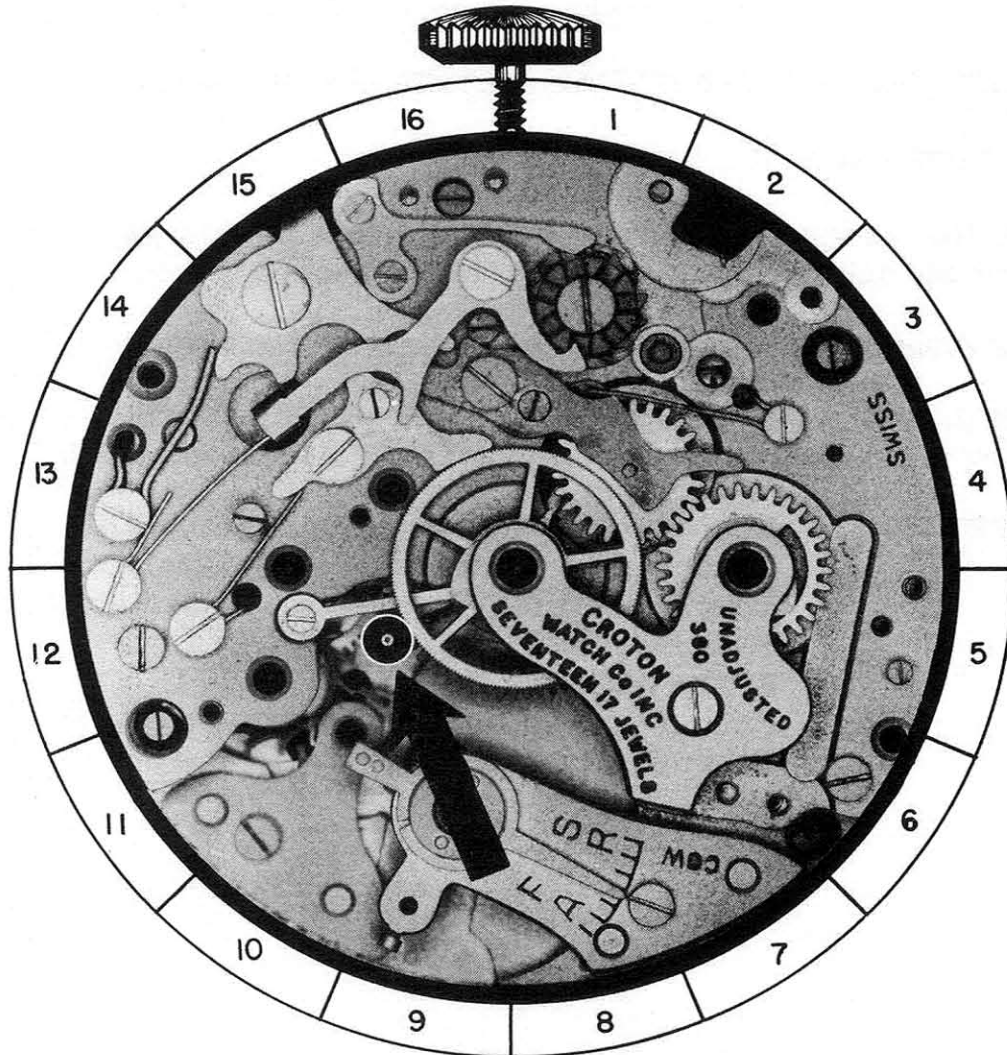

11-A

PART NO. 12

A. DISASSEMBLY PROCEDURE OF CONNECTING LEVER AND WASHER:

The connecting lever is held in place by shouldered screw SS-9, and pivots on this screw. When this screw is removed, the lever and the supporting washer may be lifted out of place.

(The shape of screw for this part is shown at bottom of page.)

B. ASSEMBLY PROCEDURE OF CONNECTING LEVER AND WASHER:

Place the supporting brass washer centered over the screw hole in the plate. Then place the connecting lever in its proper position, as shown in the photograph, with the end "A" of the connecting lever spring contacting the surface "D" of the connecting lever. Now replace shouldered screw SS-9 and check to see that the connecting lever pivots freely on this screw.

C. FUNCTION OF CONNECTING LEVER AND WASHER:

The functions of the connecting lever are:

1. It forces the chronograph pivoted detent to disengage the double intermediate pinion from the seconds wheel.
2. It disengages the brake lever from the seconds wheel.
3. It prevents the push piece for setting back to zero from being pushed when the chronograph mechanism is engaged.

REFERENCE: Connecting lever spring is Assembly 13.
Chronograph pivoted detent is Assembly 10.
Double intermediate pinion is Assembly 11.
Seconds wheel is Assembly 20.
Brake lever is Assembly 17.
Push piece for setting back to zero is Assembly 15.

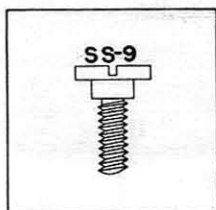

Connecting Lever and Washer
Assembly No. 12

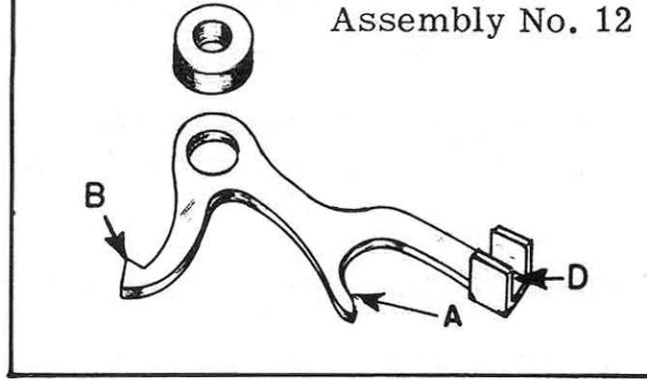

OILING

The following points should be slightly moistened with oil;

1. The shoulder of screw that connecting lever pivots on.
2. Location on connecting lever that contacts connecting lever spring.
3. Location "A" at point of contact with eccentric stud on brake lever.

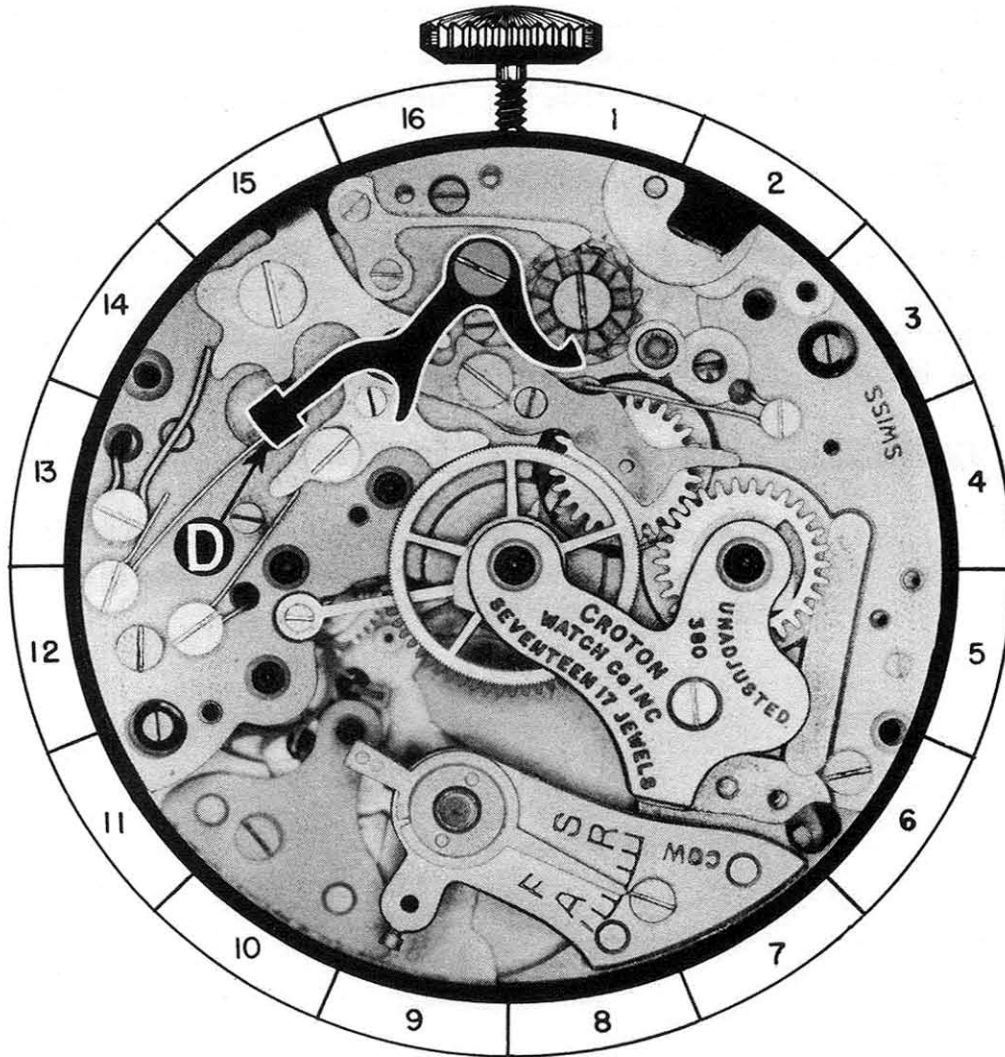

PART NO. 13

A. DISASSEMBLY PROCEDURE OF CONNECTING LEVER SPRING:

The connecting lever spring is held in place by shouldered screw SS-10. Remove this screw, and lift the spring out of place.

(The shape of screw for this part is shown at bottom of page.)

B. ASSEMBLY PROCEDURE OF CONNECTING LEVER SPRING:

Place this spring in position with the loop in the spring over the proper screw hole in the plate, and replace the shouldered screw SS-10.

C. FUNCTION OF CONNECTING LEVER SPRING:

The function of the connecting lever spring is to force the connecting lever in the direction to hold the end "B" of the connecting lever in contact with the columns of the castle wheel.

REMARKS:

The tension that the connecting lever spring holds on the connecting lever should be great enough to supply the power to move the chronograph pivoted detent in the direction to disengage the double intermediate pinion from the seconds wheel.

REFERENCE: Connecting lever is Assembly 12.
Castle wheel is Assembly 25.
Chronograph pivoted detent is Assembly 10.
Double intermediate pinion is Assembly 11.
Seconds wheel is Assembly 20.

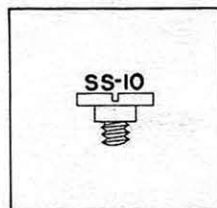

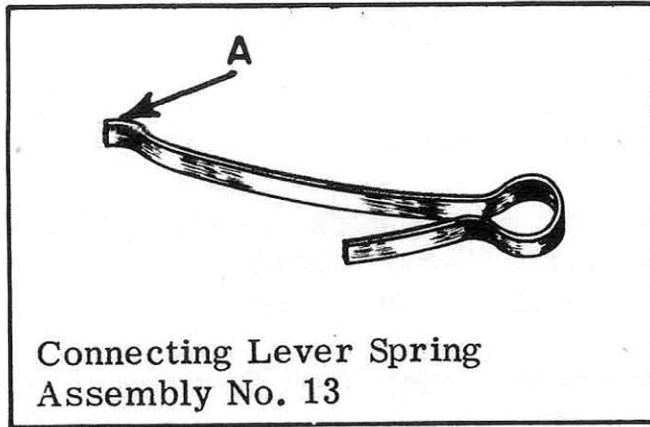

OILING

The connecting lever spring should not be oiled before the connecting lever is assembled.

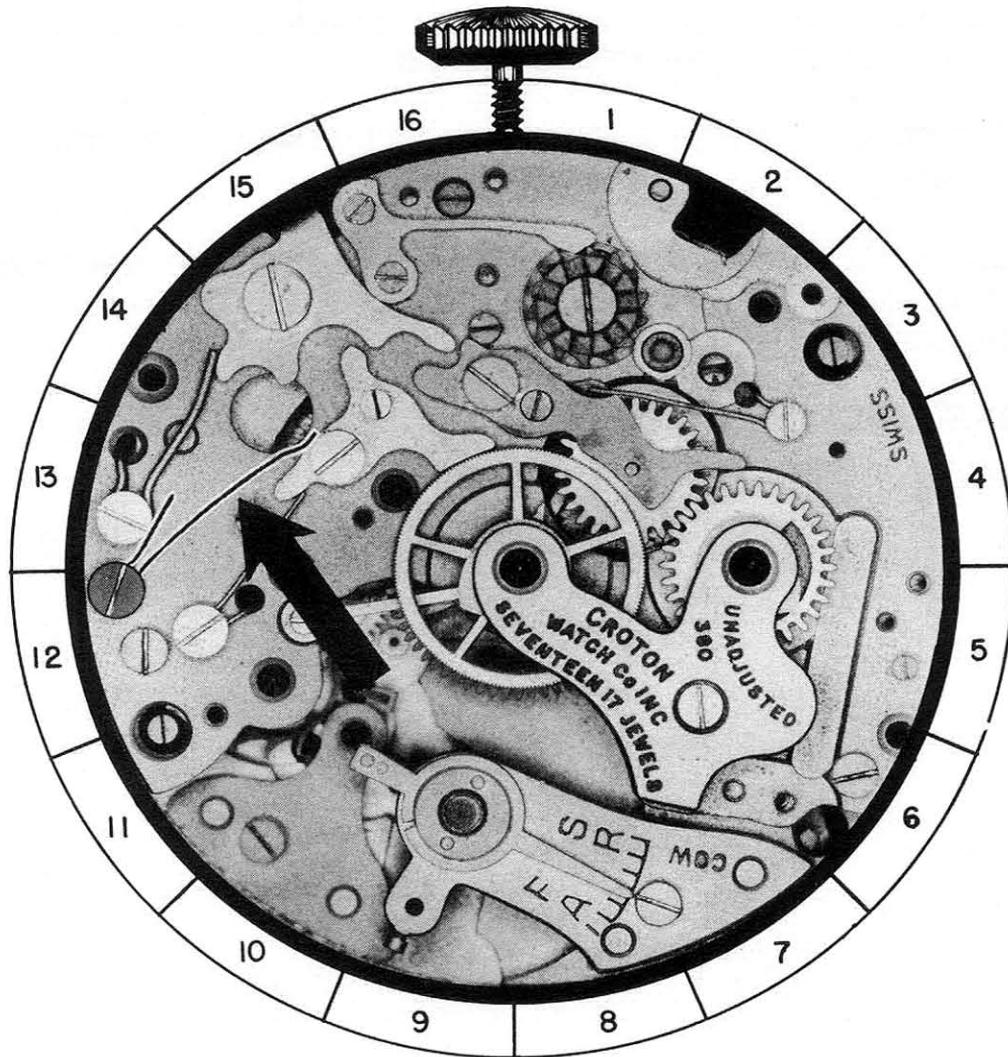

PART NO. 14

A. DISASSEMBLY PROCEDURE OF PUSH PIECE FOR SETTING BACK TO ZERO SPRING:

The push piece for setting back to zero spring is held in place by shouldered screw SS-11. When this screw has been removed, the spring may be lifted out of place.

(The shape of screw for this part is shown at bottom of page.)

B. ASSEMBLY PROCEDURE OF PUSH PIECE FOR SETTING BACK TO ZERO SPRING:

Place this spring on the plate in its proper position, with the end "B" on top of the push piece for setting back to zero, and the loop in the spring centered around the screw hole in the plate. Then replace shouldered screw SS-11, but before tightening this screw, slide the end "B" of the spring to the proper position, as shown in the photograph.

C. FUNCTION OF PUSH PIECE FOR SETTING BACK TO ZERO SPRING:

This spring holds a tension on the push piece for setting back to zero to return this push piece to its original position after being pushed.

REFERENCE: Push piece for setting back to zero is Assembly 15.

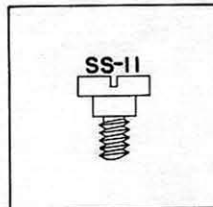

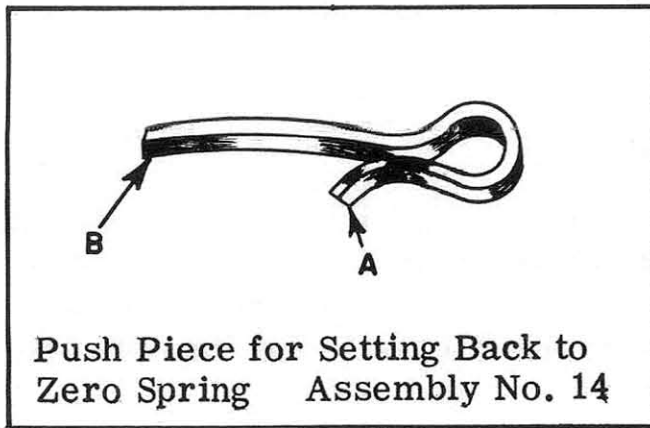

OILING

End "B" of push piece for setting back to zero spring should be oiled at the point of contact with push piece for setting back to zero.

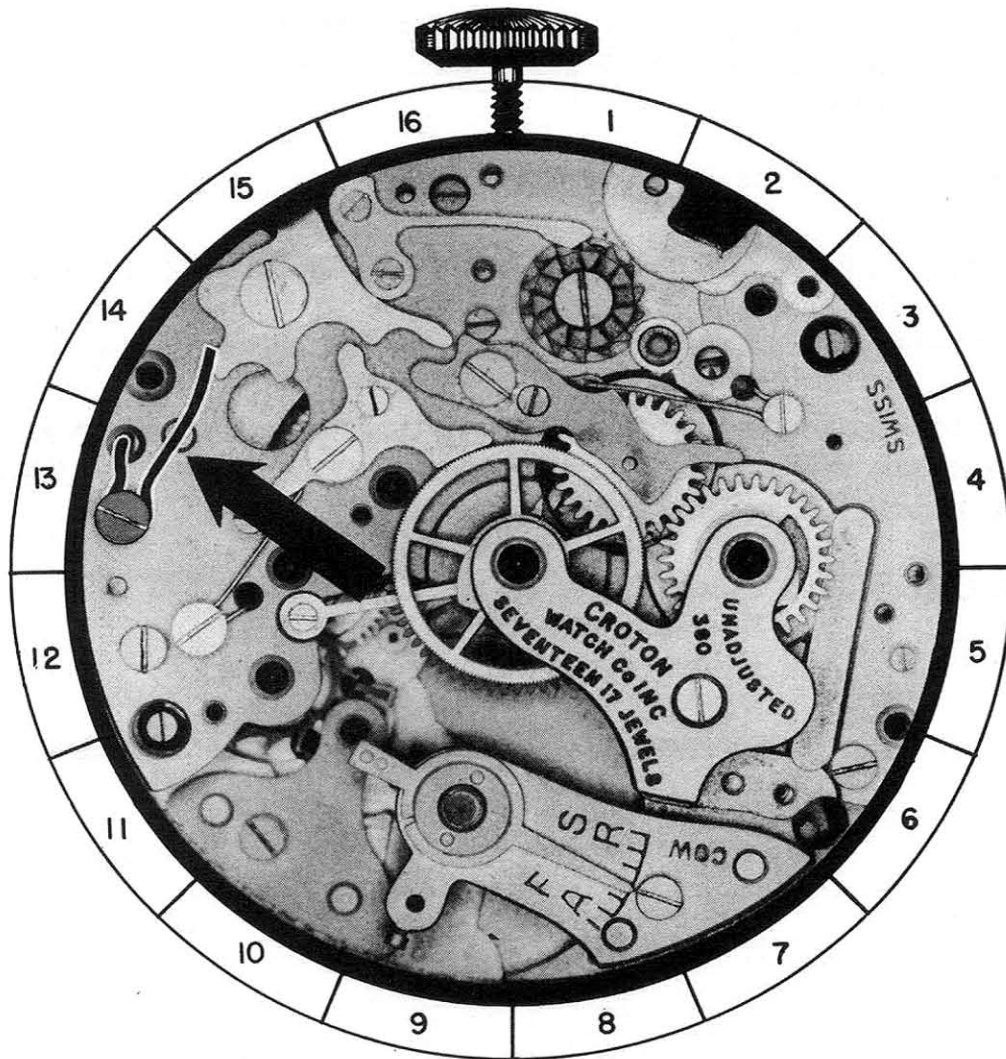

14-A

PART NO. 15

A. DISASSEMBLY PROCEDURE OF PUSH PIECE FOR SETTING BACK TO ZERO:

The push piece for setting back to zero pivots on the stud "A", which fits into a hole in the plate, and is held in place by shouldered screw SS-12. Remove the shouldered screw and lift straight up on the push piece to lift the stud "A" from the hole in the plate.

(The shape of screw for this part is shown at bottom of page.)

B. ASSEMBLY PROCEDURE OF PUSH PIECE FOR SETTING BACK TO ZERO:

Place the push piece in its proper position on the plate, with the stud "A" in the proper hole in the plate. Now replace the shouldered screw SS-12. After the screw has been replaced, check to see that the push piece moves freely under the head of this screw.

C. FUNCTION OF PUSH PIECE FOR SETTING BACK TO ZERO:

The functions of the push piece for setting back to zero are:

1. It disengages the brake lever from the seconds wheel.
2. It moves the intermittent lever and wheel away from the seconds wheel dart tooth. This in turn causes the flyback trip lever to release the flyback lever.

REFERENCE: Brake lever is Assembly 17.
Seconds wheel is Assembly 20.
Flyback trip lever is Assembly 7.
Flyback lever is Assembly 6.
Intermittent lever and wheel is Assembly 23.

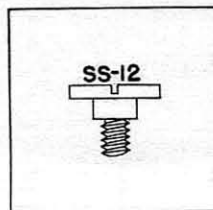

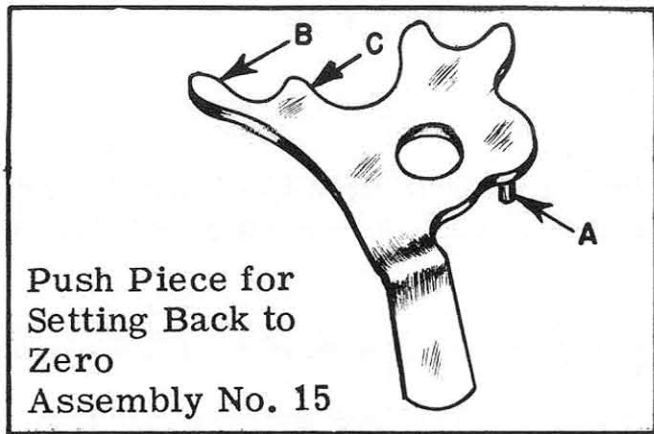

OILING

- The following points should be slightly moistened with oil:
1. The shoulder of screw that push piece pivots on.
 2. End "B" of push piece at point of contact with intermittent lever.
 3. Location "C" at point of contact with the brake lever.

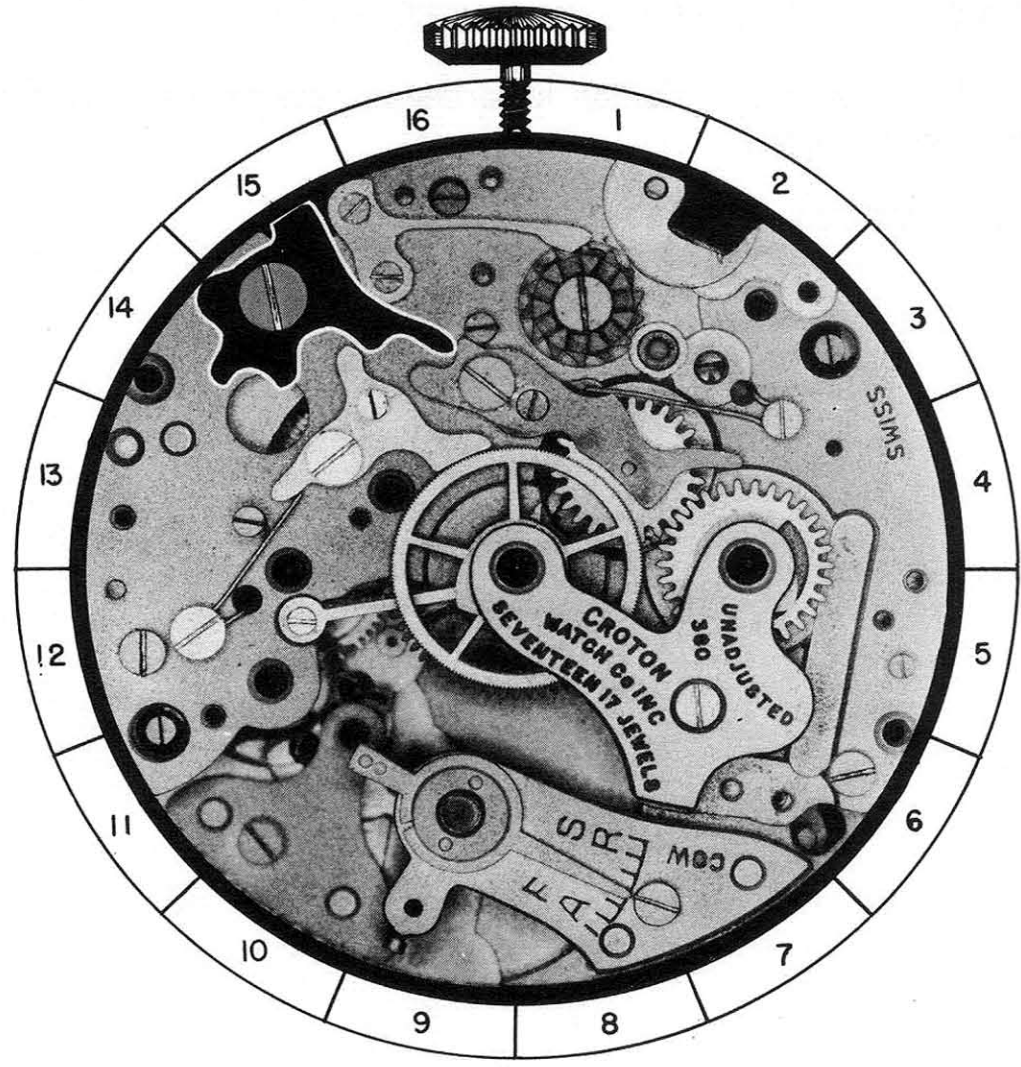

15-A

PART NO. 16

A. DISASSEMBLY PROCEDURE OF BRAKE LEVER SPRING:

The brake lever spring is held in place by shouldered screw SS-13. When this screw is removed, the spring may be lifted out of place.

(The shape of screw for this part is shown at bottom of page.)

B. ASSEMBLY PROCEDURE OF BRAKE LEVER SPRING:

Place this spring on the plate with end "A" of the spring in the proper hole, and end "B" on top of the brake lever. Now replace the screw SS-13, but before tightening this screw, slide end "B" of the spring to the correct position, as shown in the photograph.

C. FUNCTION OF BRAKE LEVER SPRING:

The function of this spring is to engage the brake lever with the seconds wheel.

REFERENCE: Brake lever is Assembly 17.
Seconds wheel is Assembly 20.

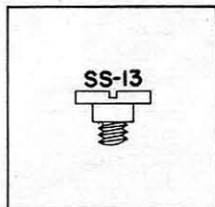

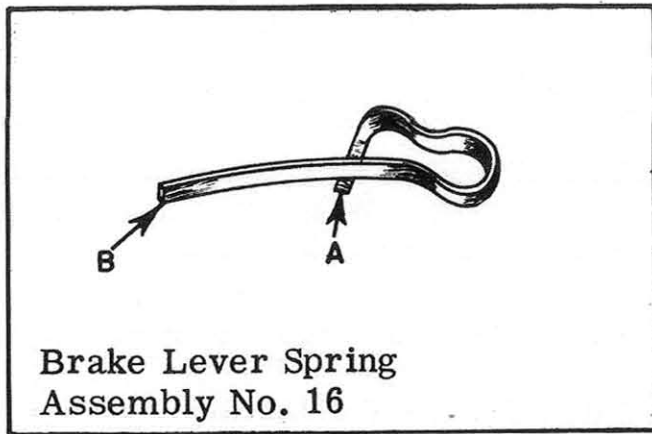

OILING

The end "B" of the brake lever spring should be slightly moistened with oil at point of contact with brake lever.

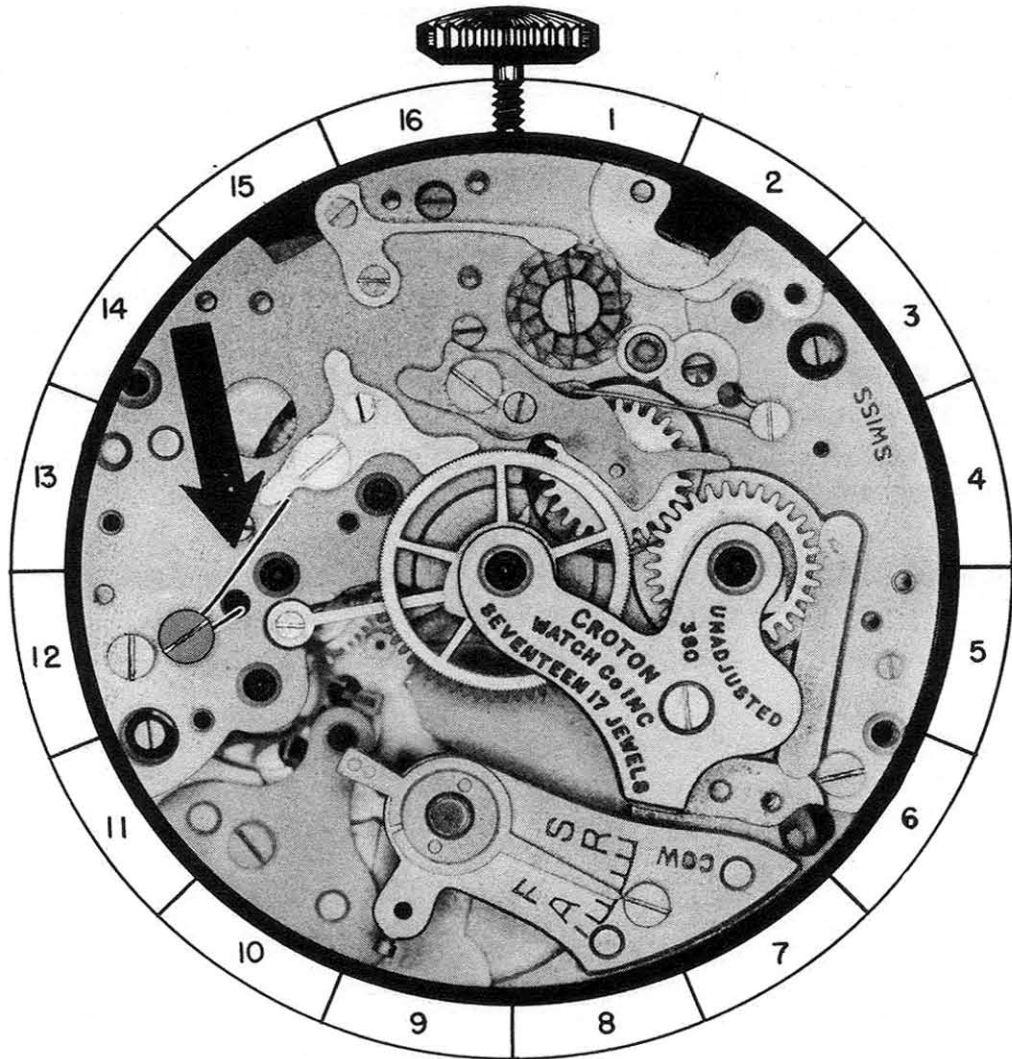

16-A

PART NO. 17

A. DISASSEMBLY PROCEDURE OF BRAKE LEVER:

The brake lever is held in place by shouldered screw SS-14, and pivots on this screw. When this screw is removed, the brake lever may be lifted out of place.

(The shape of screw for this part is shown at bottom of page.)

B. ASSEMBLY PROCEDURE OF BRAKE LEVER:

Place the brake lever on the plate in its proper position, and replace the screw SS-14. Check the brake lever to see that it pivots freely on this screw.

C. FUNCTION OF BRAKE LEVER:

The function of the brake lever is to hold the seconds wheel in a stationary position when the double intermediate pinion is disengaged from the seconds wheel.

REMARKS:

When the chronograph mechanism is engaged, part "A" of the connecting lever contacts the eccentric stud ES-2 on the brake lever, and forces the brake lever to disengage from the seconds wheel. Make sure that the eccentric stud is adjusted so that the brake lever disengages sufficiently from the seconds wheel before the double intermediate pinion engages with the seconds wheel.

REFERENCE: Double intermediate pinion is Assembly 11.
Connecting lever is Assembly 12.
Seconds wheel is Assembly 20.

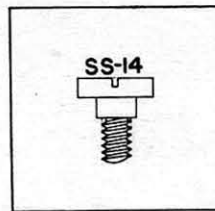

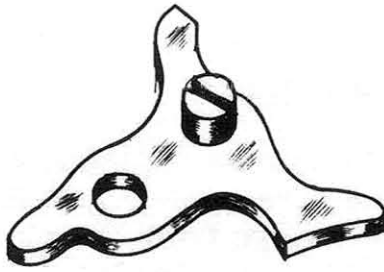

Brake Lever
Assembly No. 17

OILING

The shoulder of screw that brake lever pivots on should be slightly moistened with oil.

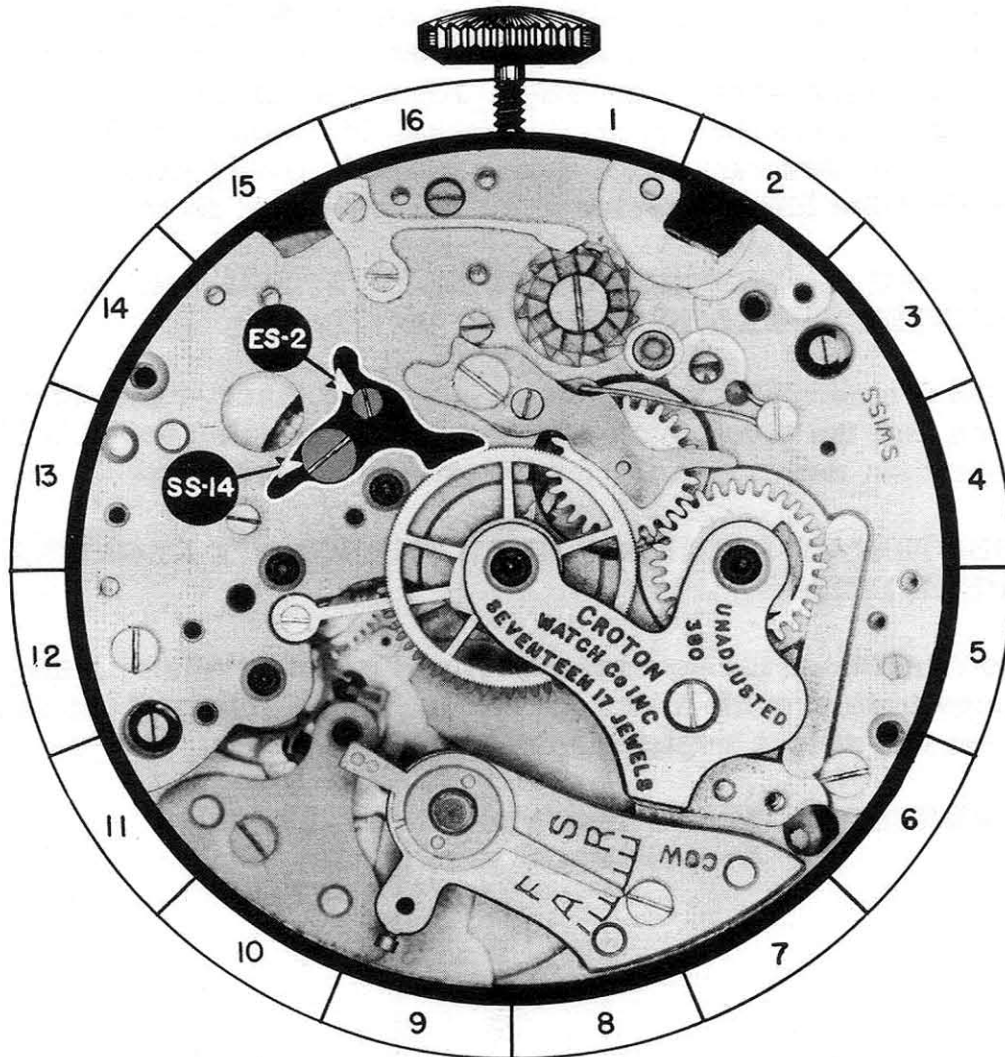

17-A

PART NO. 18

A. DISASSEMBLY PROCEDURE OF SECONDS WHEEL AND MINUTE REGISTER WHEEL BRIDGE:

The seconds wheel and minute register wheel bridge is held in place by fillister head screw FS-3 and steady pins. Remove the screw, and loosen the bridge from the plate by sliding a thin blade screwdriver between the bridge and the plate. When the steady pins are free in the plate, the bridge may be lifted from the movement.

(The shape of screw for this part is shown at bottom of page.)

B. ASSEMBLY PROCEDURE OF SECONDS WHEEL AND MINUTE REGISTER WHEEL BRIDGE:

Place the bridge in position with the steady pins in the proper holes in the plate. Now place the seconds wheel and the minute register wheel so that the pivots on these wheels enter the jewel holes. Press the bridge down with the back of tweezers, and replace fillister head screw FS-3. After this bridge has been replaced, both wheels should be checked for proper freedom. Of course, the seconds wheel should not spin freely unless the tension that the tension spring holds on this wheel is released.

C. HAZARDS IN ASSEMBLY OF SECONDS WHEEL AND MINUTE REGISTER WHEEL BRIDGE:

When pressing this bridge down to proper place, care should be taken that the pivots have entered the jewel holes in the bridge; otherwise, damage to the pivots or jewels may result.

D. FUNCTION OF SECONDS WHEEL AND MINUTE REGISTER WHEEL BRIDGE:

The function of the seconds wheel and minute register wheel bridge is to provide a bearing for the upper pivots of the seconds wheel and minute register wheel.

REFERENCE: Minute register wheel is Assembly 19.
Seconds wheel is Assembly 20.

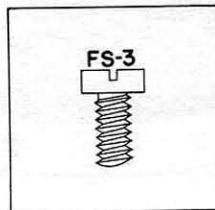

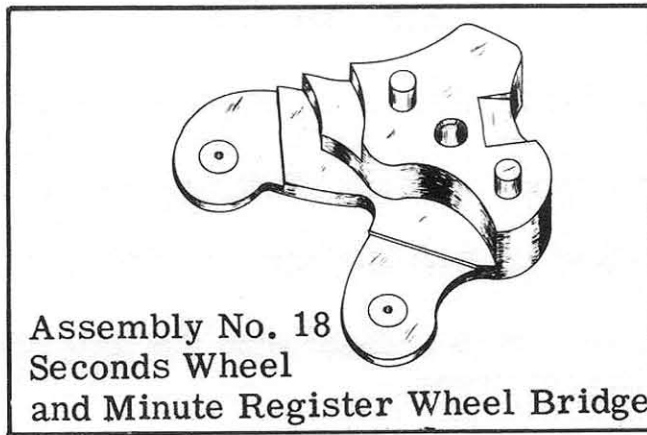

Assembly No. 18
Seconds Wheel
and Minute Register Wheel Bridge

OILING

The top and bottom pivots of the seconds wheel and minute register wheel should be oiled as you would properly oil the train pivots in a watch.

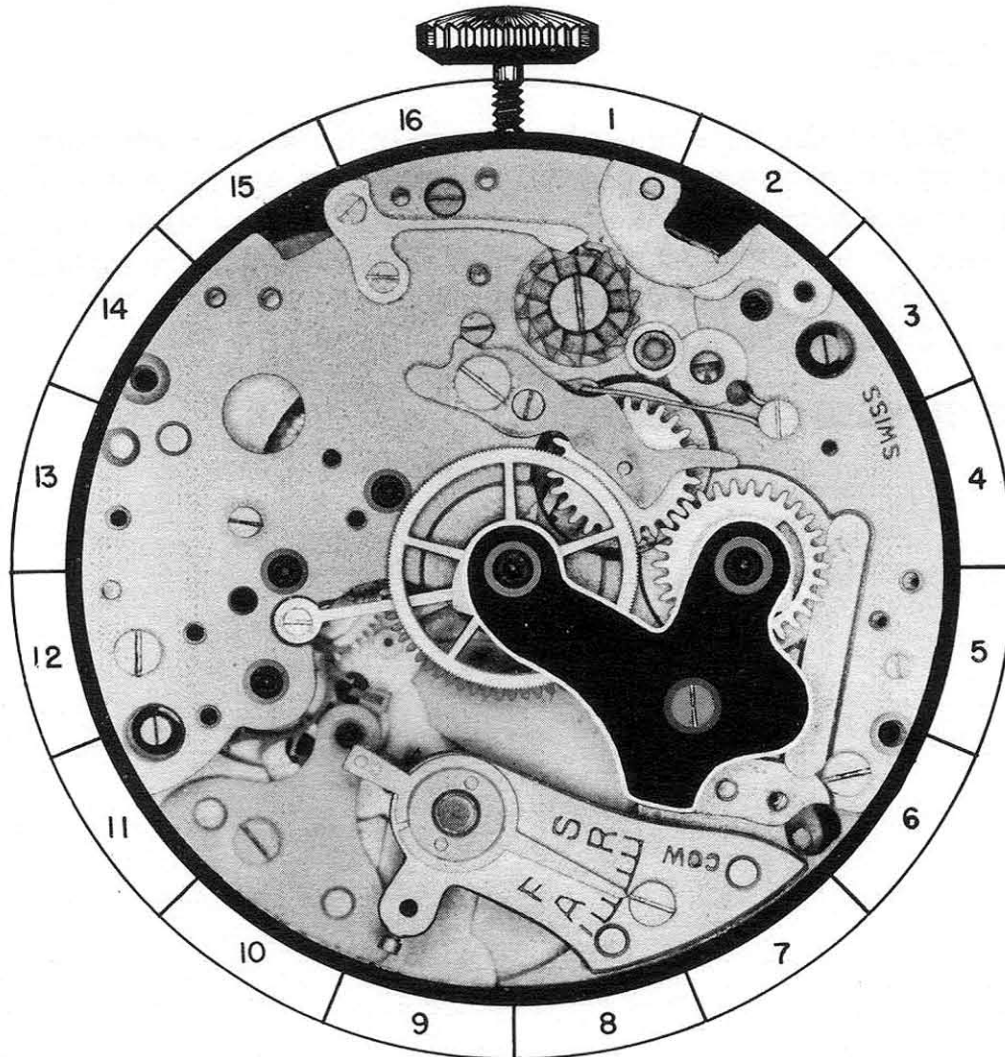

18-A

PART NO. 19

A. DISASSEMBLY PROCEDURE OF MINUTE REGISTER WHEEL:

To remove this wheel, simply lift it out of place.

B. ASSEMBLY PROCEDURE OF MINUTE REGISTER WHEEL:

Place the minute register wheel with the long pivot "A" down in the hollow barrel arbor.

C. FUNCTION OF MINUTE REGISTER WHEEL:

The function of the minute register wheel is to record the minutes that have elapsed since the beginning of the chronograph registration. This is done by a hand being attached to the long post "A" of the minute register wheel. The heart "B" is used to return the wheel to a zero position.

REMARKS:

The sides of the hearts on the seconds wheel and the minute register wheel must be highly polished, as any roughness or pits of rust may prevent the flyback lever from returning the seconds wheel and minute register wheel to a zero position. When polishing these hearts, care must be taken that the shape of the heart is not changed.

REFERENCE: Flyback lever is Assembly 6.
Seconds wheel is Assembly 20.

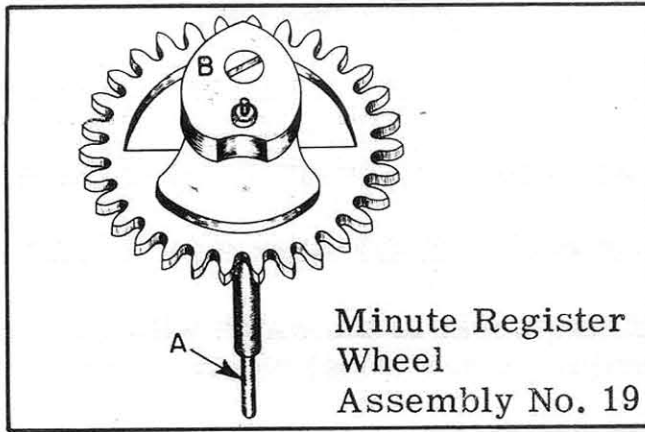

OILING

The top pivot of the minute register wheel should be oiled after the bridge for this wheel is replaced in the watch. Oil this pivot as you would oil a train pivot.

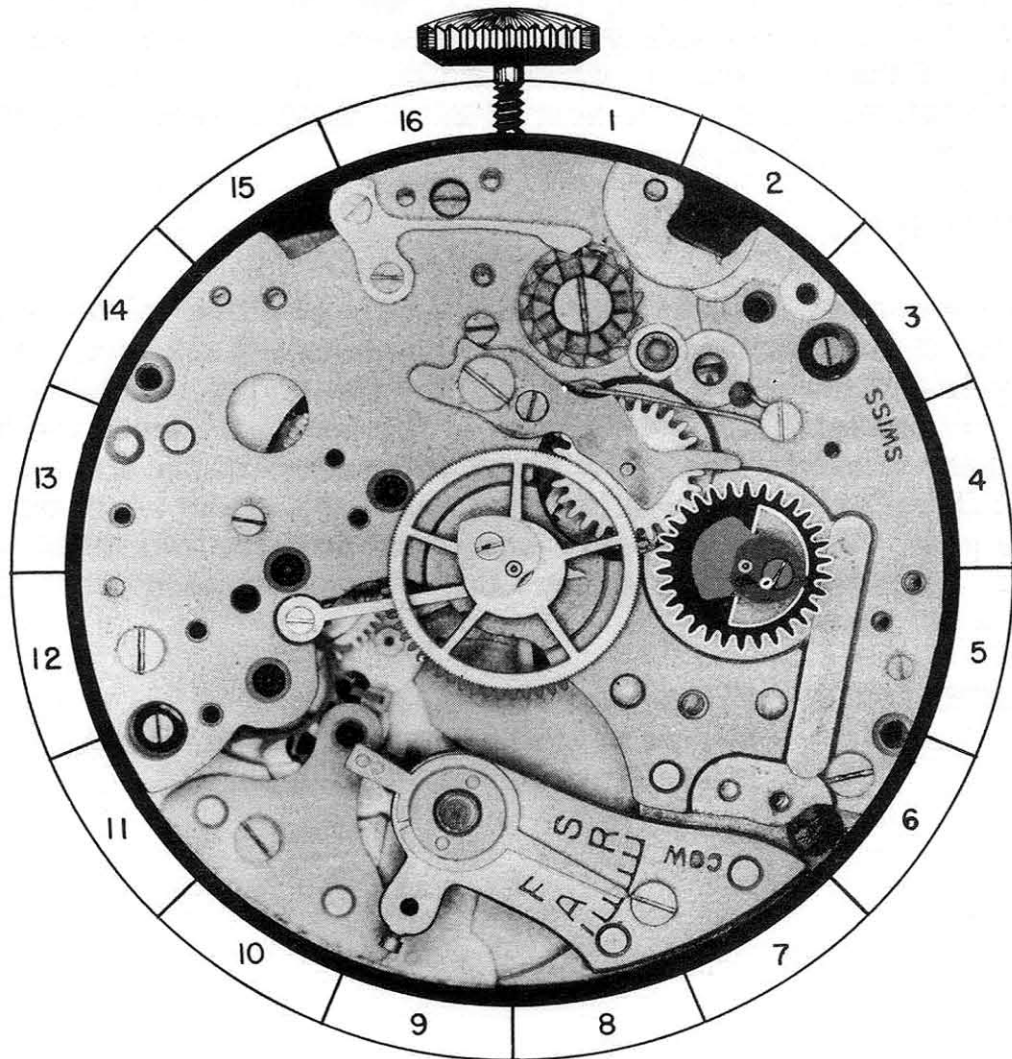

19-A

PART NO. 20

A. DISASSEMBLY PROCEDURE OF SECONDS WHEEL:

To remove this wheel, simply lift it out of place.

B. ASSEMBLY PROCEDURE OF SECONDS WHEEL:

Place the seconds wheel in the watch with the long post "A" down in the hollow center wheel pinion.

C. FUNCTION OF SECONDS WHEEL:

The function of this wheel is to register the seconds that have elapsed since the beginning of a registration. This is done by means of a hand being attached to the seconds wheel post "A". Also, the seconds wheel must move the minute register wheel forward one tooth each time the seconds wheel makes one revolution. This is done by the dart tooth "C", which is firmly attached to the seconds wheel. The dart tooth meshes with the teeth of the intermittent wheel, which in turn moves the minute register wheel. The heart "B" is used to return the seconds wheel to a zero position.

REMARKS:

The seconds wheel is returned to a zero position by the flyback lever contacting the heart "B". When the flyback lever is being moved towards the heart, and the flat end of the flyback lever is pressing against the side of the heart, it forces the heart and the wheel to turn. The heart will turn until the flat end of the flyback lever sets across the two lobes of the heart near the post. With the pressure equalized on these two lobes, the heart will turn no further, and this is what is commonly known as a zero position.

REFERENCE: Flyback lever is Assembly 6.
Minute register wheel is Assembly 19.
Intermittent wheel is Assembly 23.

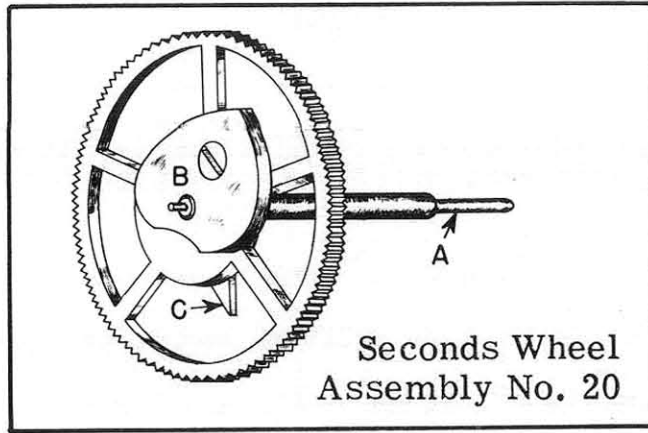

OILING

The top pivot of the seconds wheel should be oiled after the bridge for this wheel is replaced. Oil this pivot as you would oil a train pivot in a watch.

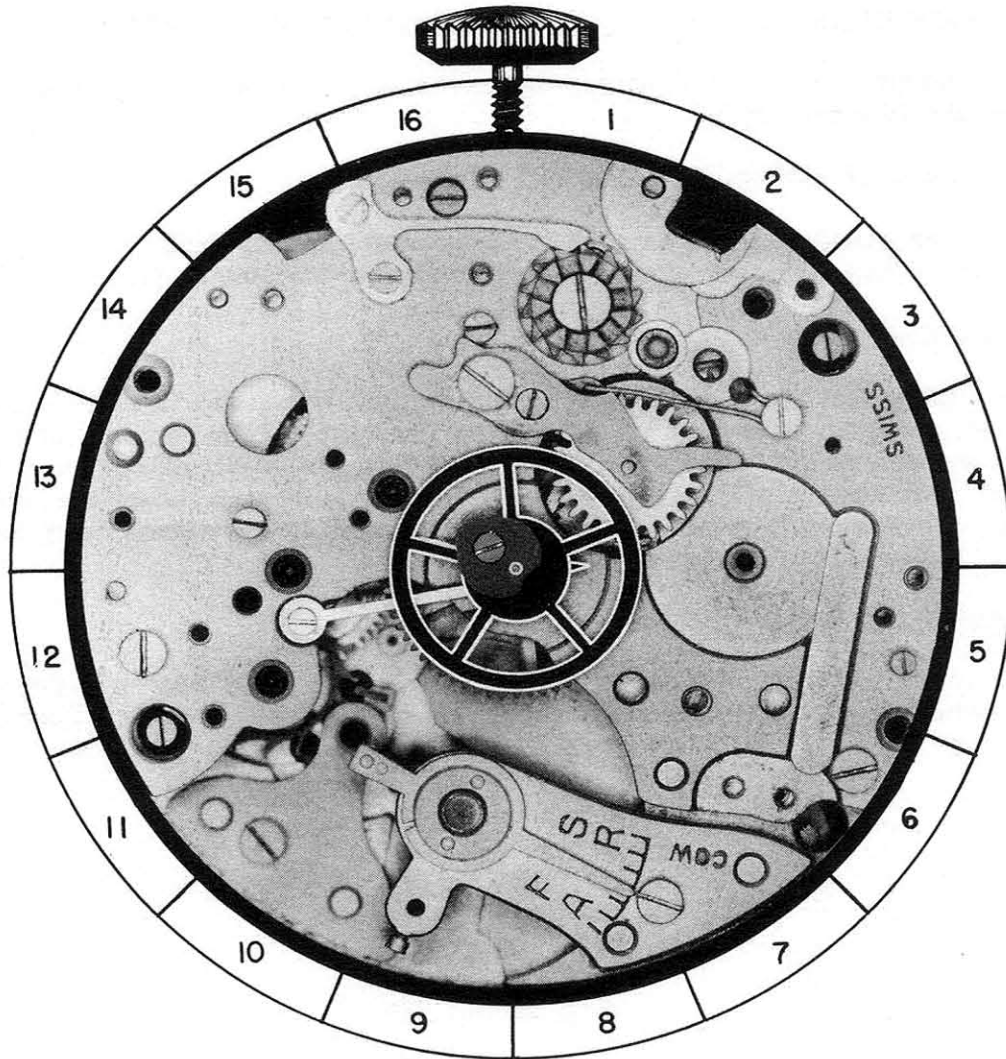

A. DISASSEMBLY PROCEDURE OF SECONDS WHEEL TENSION SPRING:

The seconds wheel tension spring is held in place by fillister head screw FS-4. When this screw is removed, the tension spring will be free on the plate and can be removed.

(The shape of screw for this part is shown at bottom of page.)

B. HAZARDS IN DISASSEMBLY OF SECONDS WHEEL TENSION SPRING:

Be careful in removing this spring. It is a very thin soft spring, and easily bent.

C. ASSEMBLY PROCEDURE OF SECONDS WHEEL TENSION SPRING:

Place the spring in its proper position on the plate, with the hole in the spring over the proper screwhole. (Be certain that the right side of the spring is up, so that end "A" rises above the level of the plate.) Now replace fillister head screw FS-4, but before tightening this screw, place the end "A" of the spring along the side of the hole in the hollow staff of the center wheel.

D. HAZARDS IN ASSEMBLY OF SECONDS WHEEL TENSION SPRING:

The seconds wheel tension spring is a soft thin spring, and easily mutilated. Use care in replacing it.

E. FUNCTION OF SECONDS WHEEL TENSION SPRING:

This spring holds a tension on the seconds wheel so that while the wheel is turning, it has a smooth action, with no irregular jumping or jerking.

REMARKS:

The tension that this spring holds on the seconds wheel should be properly adjusted, so that it is neither too strong nor too weak. If the seconds hand moves forward with an irregular motion, the tension of the spring must be increased. If the oscillation of the balance wheel decreases noticeably when the chronograph mechanism is engaged, in spite of the chronograph wheels being free, then the tension of the spring must be decreased.

REFERENCE: Seconds wheel is Assembly 20.

(For more detailed information in regards to setting the tension of the seconds wheel tension spring, refer to volume 24 of the Esembl-O-Graf Library.)

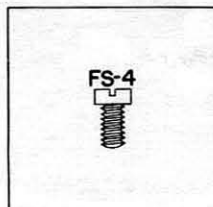

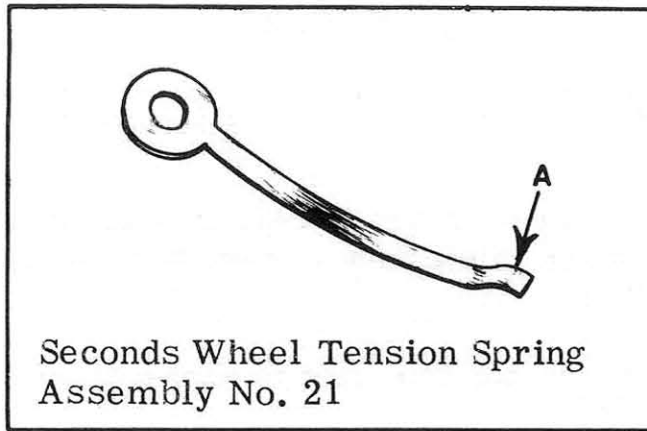

OILING

The seconds wheel tension spring should not be oiled.

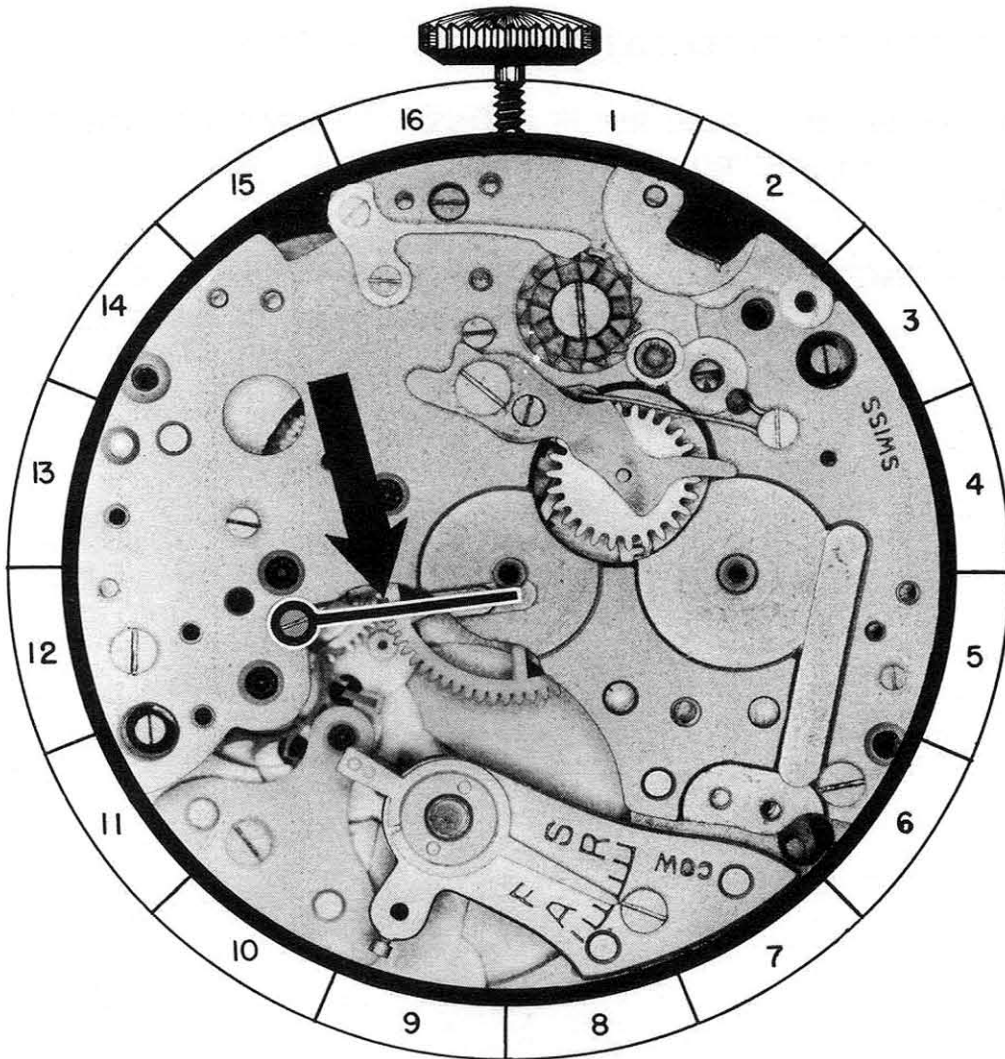

21-A

PART NO. 22

A. DISASSEMBLY PROCEDURE OF INTERMITTENT LEVER SPRING:

The intermittent lever spring is held in place by shouldered screw SS-15. When this screw is removed, the spring may be lifted out of place.

(The shape of screw for this part is shown at bottom of page.)

B. ASSEMBLY PROCEDURE OF INTERMITTENT LEVER SPRING:

Place this spring on the plate with the end "A" in the proper hole in the plate, and the end "B" on top of the intermittent lever. Now replace shouldered screw SS-15, but before tightening this screw, slide the end "B" of the spring to the correct position, in recess "C" in the intermittent lever.

C. FUNCTION OF INTERMITTENT LEVER SPRING:

The function of this spring is to force the intermittent lever to engage the intermittent wheel with the seconds wheel dart tooth.

REFERENCE: Seconds wheel dart tooth is Assembly 20.
Intermittent lever and wheel is Assembly 23.

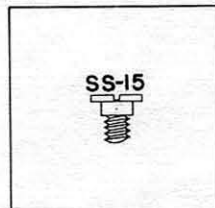

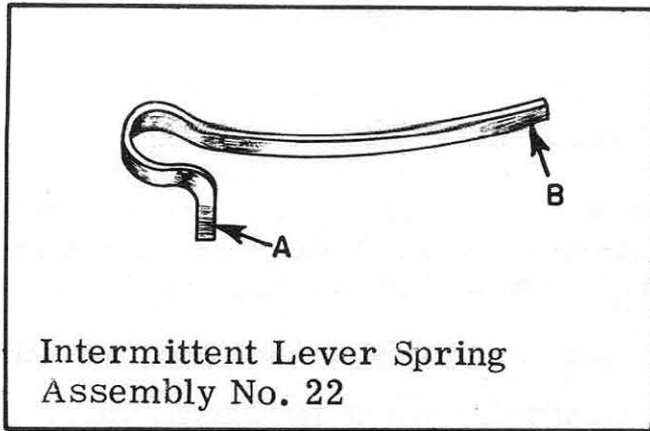

OILING

The end "B" of the intermittent lever spring should be slightly moistened with oil at the point of contact with the intermittent lever.

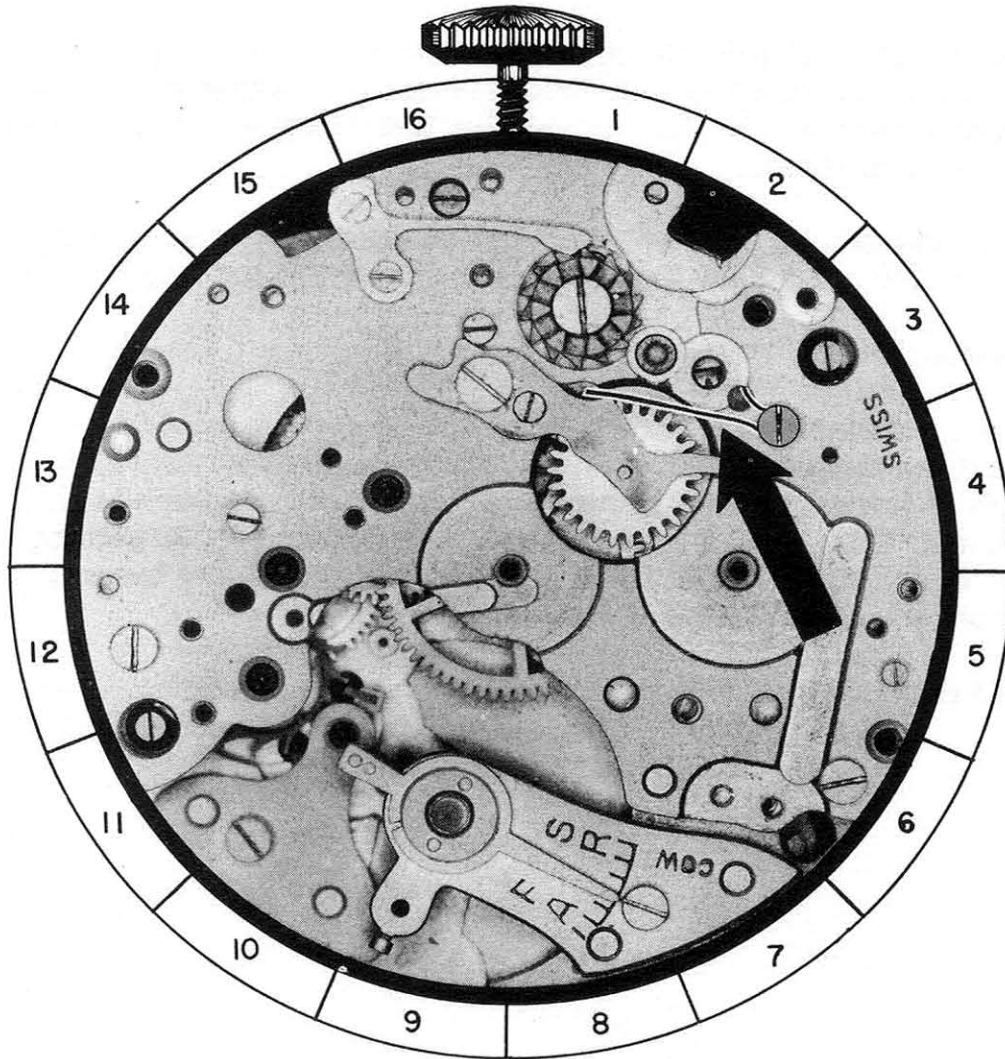

PART NO. 23

A. DISASSEMBLY PROCEDURE OF INTERMITTENT LEVER AND WHEEL ASSEMBLY:

The intermittent lever pivots on an eccentric stud, and is held in place by shouldered screw SS-16. When this screw is removed, the lever may be lifted from the stud and out of place.

(The shape of screw for this part is shown at bottom of page.)

B. ASSEMBLY PROCEDURE OF INTERMITTENT LEVER AND WHEEL ASSEMBLY:

Place the intermittent lever and wheel assembly in its proper position on the plate, with the hole "A" in the lever over the eccentric stud ES-4. Then replace shouldered screw SS-16. The intermittent lever must pivot freely on the eccentric stud ES-4.

C. FUNCTION OF INTERMITTENT LEVER AND WHEEL ASSEMBLY:

The function of the intermittent lever is to engage and disengage the intermittent wheel "B" with the seconds wheel dart tooth. The intermittent lever also moves the flyback trip lever to release the flyback lever.

The function of the intermittent wheel "B" is to transfer the power from the dart tooth to the minute register wheel.

REMARKS:

When the push piece for setting back to zero is pushed, it forces the intermittent lever to move the intermittent wheel out of the path of the dart tooth, immediately before the flyback lever is released. This makes it impossible for the dart tooth to hang up on the intermittent wheel while the seconds wheel and the minute register wheel are being returned to zero.

REFERENCE: Flyback trip lever is Assembly 7.
Minute register wheel is Assembly 19.
Seconds wheel is Assembly 20.

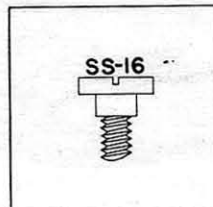

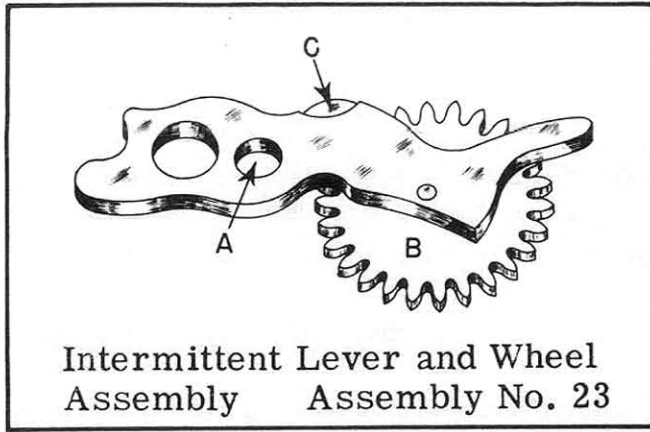

Intermittent Lever and Wheel
Assembly Assembly No. 23

OILING

The eccentric stud that intermittent lever pivots on should be slightly moistened with oil.

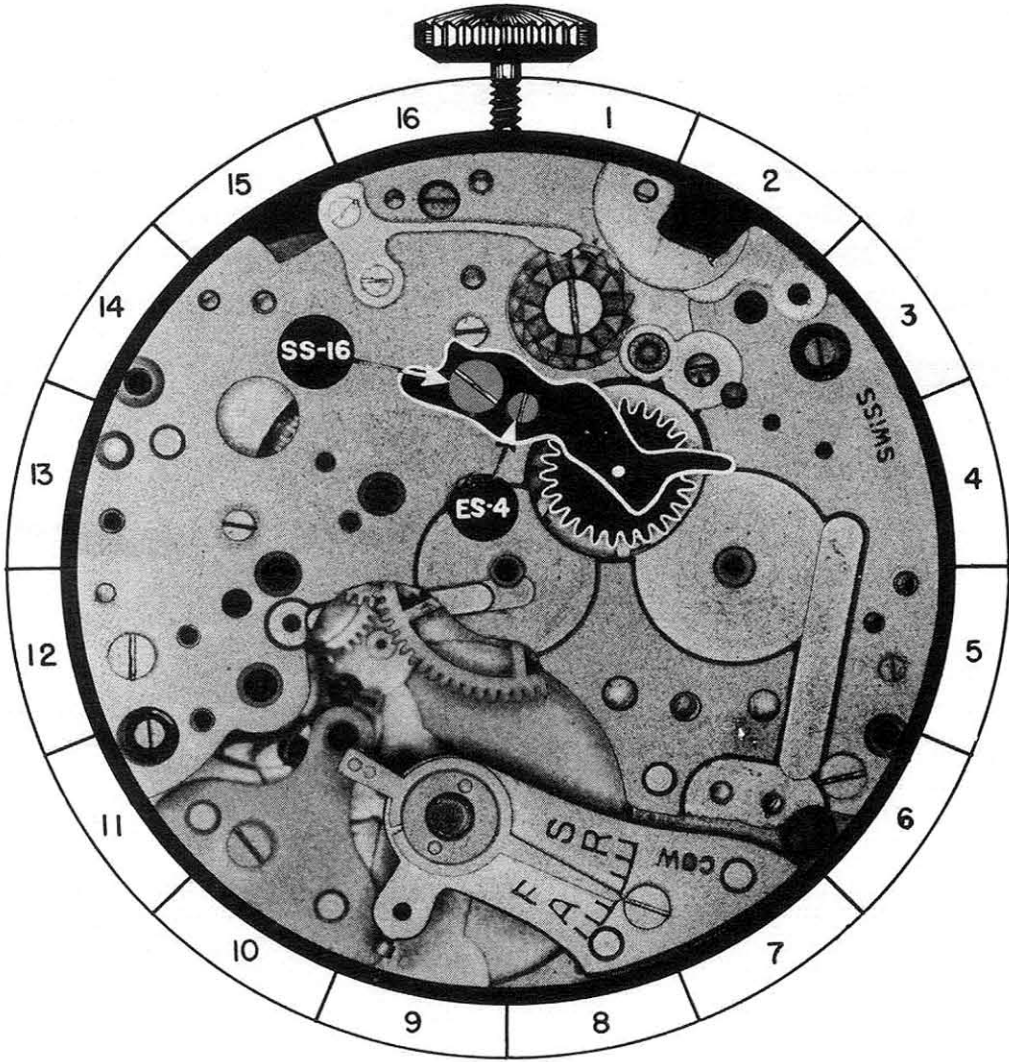

23-A

PART NO. 24

A. DISASSEMBLY PROCEDURE OF CASTLE WHEEL PAWL:

The castle wheel pawl is held in place by two identical beveled countersink screws, BS-1 and BS-2. When these screws are removed, the pawl may be lifted out of place.

(The shape of screws for this part is shown at bottom of page.)

B. ASSEMBLY PROCEDURE OF CASTLE WHEEL PAWL:

Place the castle wheel pawl in its proper position on the plate. Replace the screw BS-1, but do not tighten it. Then place the end "A" of the pawl on top of the ratchet teeth, and between two columns of the castle wheel. Now replace the screw BS-2, but before tightening these screws, place the end "A" of the pawl in its correct position on the outer surface of the ratchet teeth.

C. FUNCTION OF CASTLE WHEEL PAWL:

The function of this pawl is to assure that the castle wheel turns exactly the right amount each time the actuating push piece is pushed. This pawl also holds the castle wheel in the correct position until the actuating push piece is pushed.

REFERENCE: Castle wheel is Assembly 25.

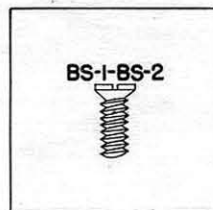

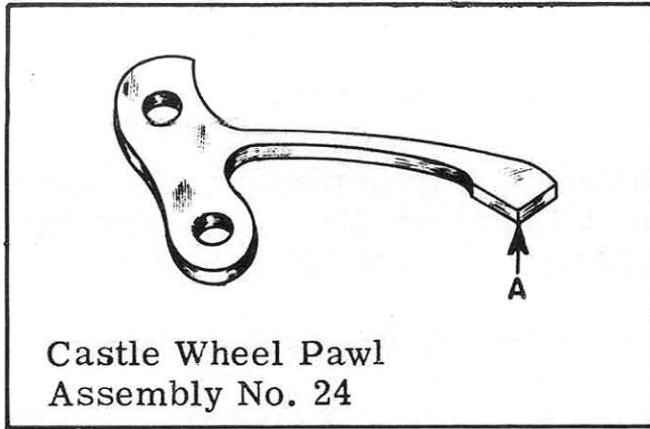

OILING

The castle wheel pawl should not be oiled as it receives oil from the ratchet teeth on the castle wheel.

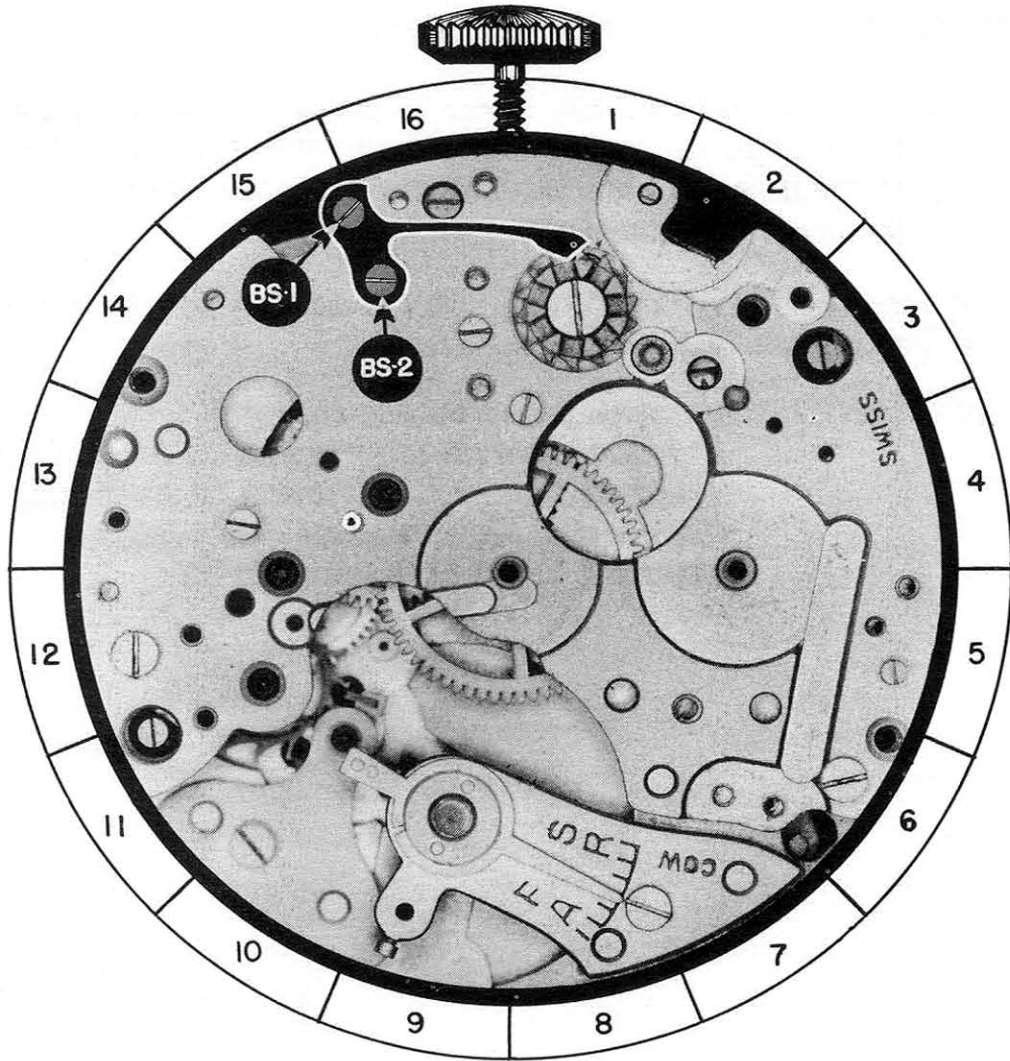

PART NO. 25

A. DISASSEMBLY PROCEDURE OF CASTLE WHEEL:

The castle wheel is held in place by shouldered screw SS-17, and pivots on this screw. After the screw has been removed, the wheel will be free on the plate and may be removed.

(The shape of screw for this part is shown at bottom of page.)

B. ASSEMBLY PROCEDURE OF CASTLE WHEEL:

Place the castle wheel in its proper position on the plate, and replace shouldered screw SS-17. The castle wheel should pivot freely on this screw, but yet not have excessive freedom.

C. FUNCTION OF CASTLE WHEEL:

The functions of the castle wheel are:

1. It forces the connecting lever to pivot in the direction to:
 - A. Disengage the brake lever from the seconds wheel.
 - B. Permit the double intermediate pinion to engage with the seconds wheel.
2. It forces the flyback lever away from the hearts when the chronograph is being engaged.

REFERENCE: Flyback lever is Assembly 6.
Chronograph pivoted detent is Assembly 10.
Double intermediate pinion is Assembly 11.
Connecting lever is Assembly 12.
Seconds wheel is Assembly 20.

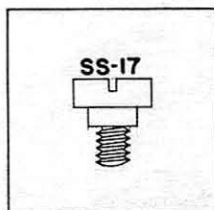

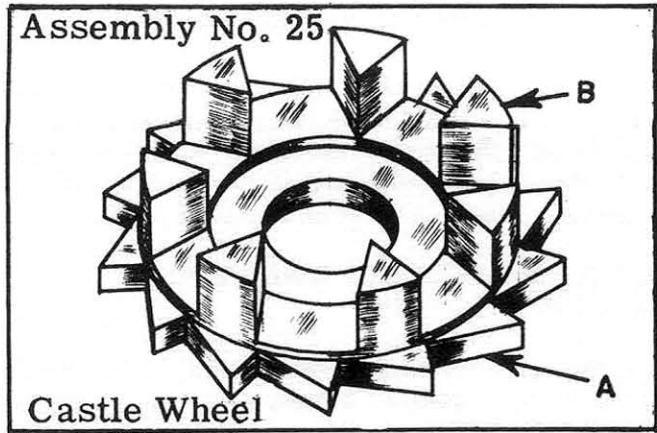

OILING

- The following points should be slightly moistened with oil;
1. The shoulder of screw that the castle wheel pivots on.
 2. The outer surface of the ratchet teeth "A" on the castle wheel.
 3. The columns "B" at the points of contact with other parts of the chronograph mechanism.

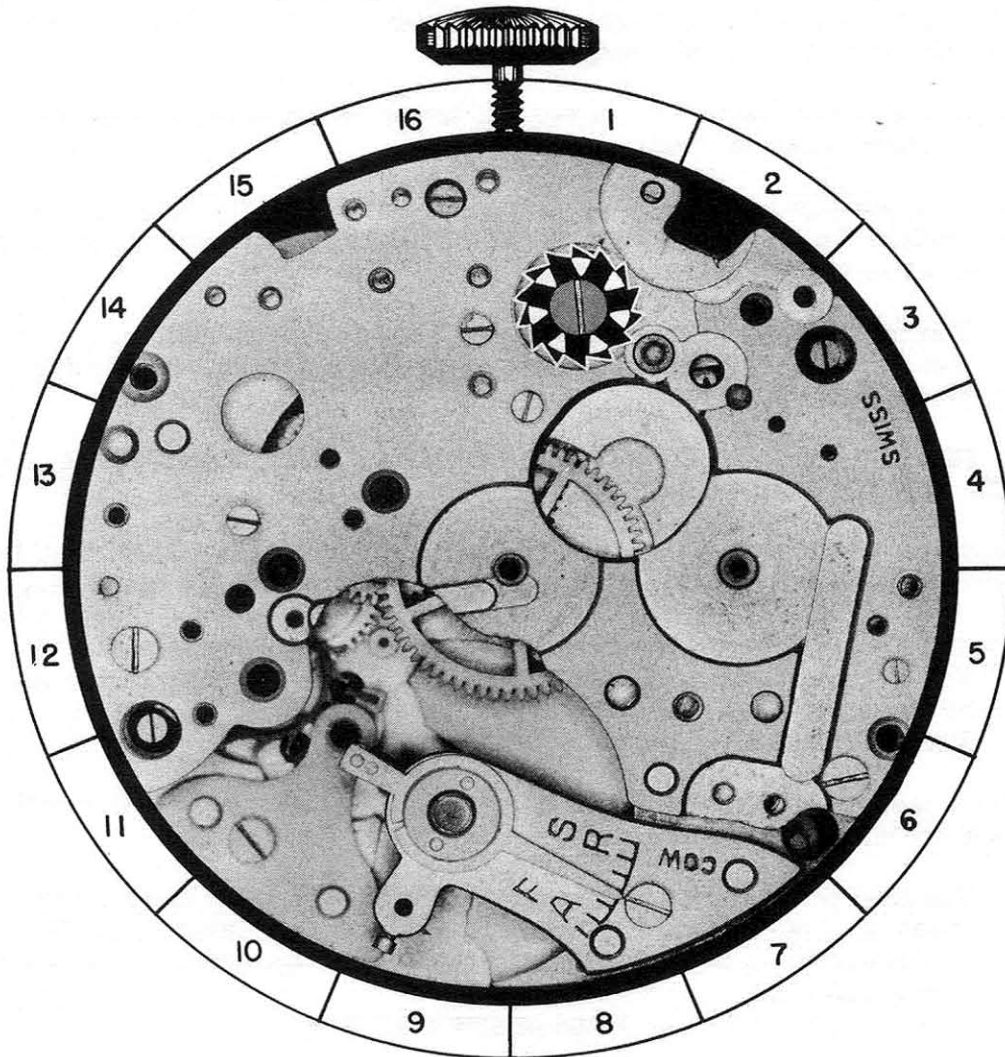

FUNCTIONAL RESULTS

After completely assembling the chronograph, with the exception of the back of the case, place the chronograph in front of you, pendant up, with the back of the chronograph facing you. Now by pushing the button at the right of the pendant, bring the chronograph mechanism to such a position that the double intermediate pinion is disengaged from the seconds wheel, and proceed as follows.

1. PUSH THE BUTTON AT THE LEFT OF THE PENDANT, RELEASE IT, AND CHECK THE FOLLOWING:

- A. Check to see that the seconds wheel and minute register wheel return the hands connected to these wheels to a zero position. If the seconds hand and minute register hand do not return to a zero position, the cause may be:
 - a. The hands not being set correctly, or being loose, (either the brass tube of the hand loose on the post, or the hand loose on the brass tube).
 - b. The seconds wheel or the minute register wheel binding.
 - c. The flyback lever binding.
 - d. The flyback lever spring not holding a sufficient tension on the flyback lever.
- B. Check to see that the ends "A" and "B" of the flyback lever are of the correct length to hold the seconds wheel stationary, while permitting the minute register wheel to turn very slightly.

(For more detailed information in regards to the returning to zero function, refer to the Function Book, Volume 24.)

- C. Check to see that end "A" of the minute register pawl is centered between two teeth of the minute register wheel. If the end of the pawl is not centered between two teeth, the cause may be:
 - a. The intermittent wheel or the minute register wheel binding.
 - b. The minute register pawl not holding a proper tension on the minute register wheel teeth.

2. PUSH THE BUTTON AT THE RIGHT OF THE PENDANT, RELEASE IT, AND CHECK THE FOLLOWING:

- A. Check the depthing of the teeth of the double intermediate pinion with the teeth of the seconds wheel. If this depthing is incorrect, the cause may be:
 - a. The chronograph pivoted detent not pivoting freely on the post.
 - b. The chronograph pivoted detent spring not holding a sufficient tension on the chronograph pivoted detent.
 - c. Eccentric stud ES-1 not being properly adjusted.
- B. Check the depthing of the seconds wheel dart tooth with the intermittent wheel teeth. If this depthing is incorrect, the cause may be:
 - a. The intermittent lever binding on eccentric stud ES-4, or under the head of the shouldered screw that holds the intermittent lever in place.
 - b. The intermittent lever spring not holding a sufficient tension on the intermittent-lever.
 - c. Eccentric stud ES-3 not being properly adjusted.

(Continued on next page)

FUNCTIONAL RESULTS
(Continued)

REMARKS:

If the depth of the intermittent wheel teeth with the seconds wheel dart tooth is too deep, the dart tooth may move the intermittent wheel and the minute register wheel two teeth each time the seconds wheel makes one revolution. If this depth is too shallow, the dart tooth may not move the intermittent wheel and the minute register wheel sufficiently to permit the minute register pawl to enter the space between the next two teeth of the minute register wheel. In such a case, there will be no registration of the minutes at all.

C. Check to see that the seconds hand moves forward in a steady manner, with no irregular jumping or jerking.

If there is such an irregular movement of the seconds hand, it should be corrected by increasing the tension of the seconds wheel tension spring.

3. PUSH THE BUTTON AT THE RIGHT OF THE PENDANT A SECOND TIME, RELEASE IT, AND CHECK THE FOLLOWING:

A. Check to see that the brake lever is in contact with the seconds wheel teeth. If the brake lever is not in contact with the seconds wheel teeth, the cause may be:

- a. The brake lever not pivoting freely.
- b. The brake lever spring not holding a sufficient tension on the brake lever.

B. Check to see that the double intermediate pinion is disengaged from the seconds wheel. If the double intermediate pinion is not disengaged from the seconds wheel, the cause may be:

- a. The chronograph pivoted detent not pivoting freely.
- b. The connecting lever spring not holding a sufficient tension on the connecting lever.
- c. The chronograph pivoted detent spring holding too strong a tension on the chronograph pivoted detent.

C. Check to see that the flyback trip lever holds the flyback lever away from the hearts on the seconds wheel and minute register wheel.

If the flyback trip lever does not hold the flyback lever away from the hearts, the cause may be:

- a. The flyback trip lever not pivoting freely.
- b. The flyback trip lever spring not holding a sufficient tension on the flyback trip lever.
- c. The columns of the castle wheel not moving the flyback lever far enough away from the hearts to permit the flyback trip lever to lock the flyback lever. (This can be corrected by stretching the end of the flyback lever that works in conjunction with the columns of the castle wheel.)
- d. Eccentric stud ES-4 being turned to a position away from the center of the watch, so that the intermittent lever interferes with the flyback trip lever.

THE TACHOMETER

- A. The tachometer is used to indicate the speed of an object in miles per hour. A tachometer can only indicate the average speed of an object traveling over a course of a measured mile.

METHOD OF USING TACHOMETER

1. Start the chronograph sweep second hand at the exact moment the object starts to travel the measured distance of one mile.
2. When the object has traveled the course of one mile, stop the chronograph sweep second hand. The point on the tachometer scale where the sweep second hand stopped will indicate the average speed in miles per hour.

SPLIT SECOND SCALE

- B. This scale is divided into 300 divisions, each division indicating $\frac{1}{5}$ of a second. Every fifth division is marked with extra long lines denoting one second.

The main purpose of this scale is to measure a fraction of a second accurately.

MINUTE REGISTER

- C. The minute register hand indicates on the dial the number of minutes that have elapsed since the beginning of the registration of the sweep second hand. One complete revolution of the minute register hand indicates the passage of 30 minutes.

SECOND HAND

- D. The second hand indicates the passing of seconds, and should move one space each second. One complete revolution of the hand denotes passage of one minute. This hand is independent of the chronograph mechanism, and continues to register the seconds as long as the watch is running.

TELEMETER

- E. The telemeter is used to denote the number of miles between two points. This is done by comparing the speed of light to the speed of sound.

METHOD OF USING TELEMETER

1. Start the chronograph sweep second hand when you see lightning.
2. Stop the chronograph sweep second hand when you hear the thunder. The point on the telemeter scale where the sweep second hand stopped will indicate the distance in miles that the lightning is away from you.

THE CHRONOGRAPH DIAL

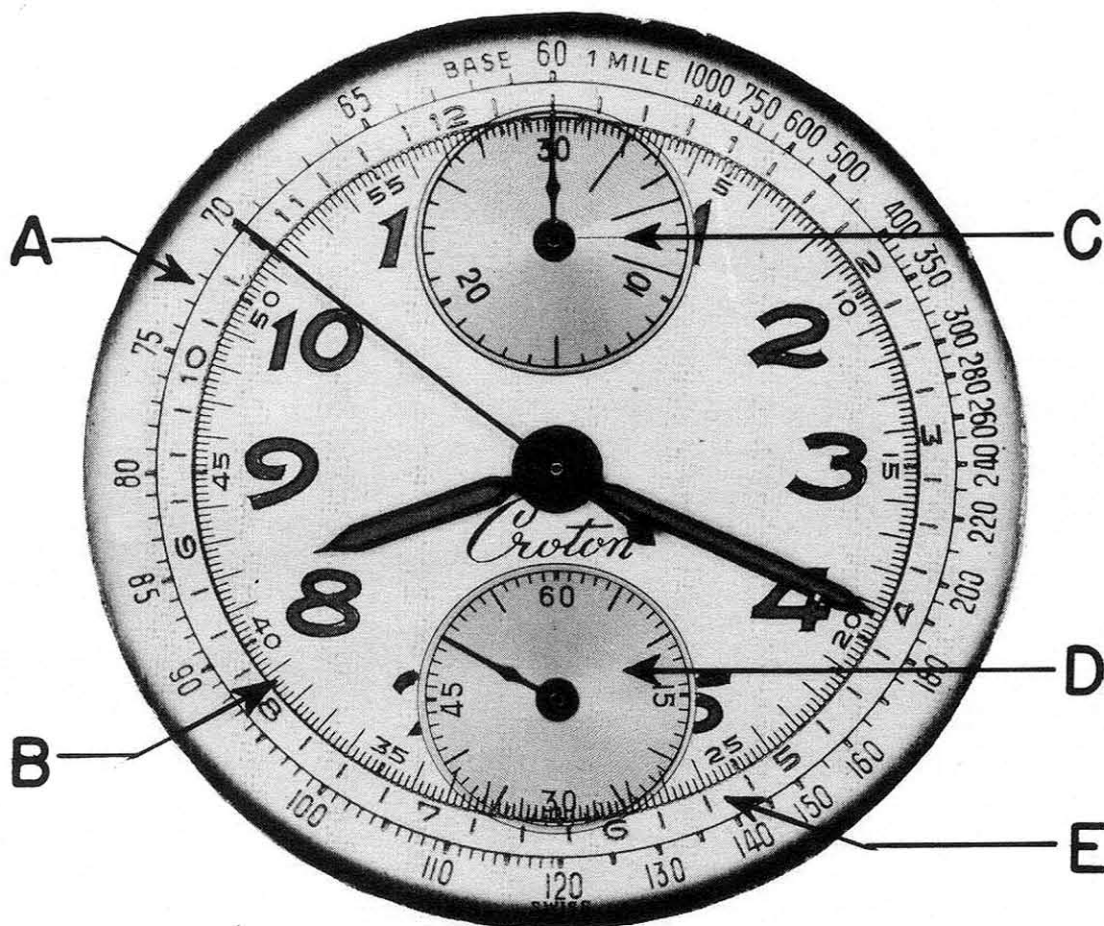

SETTING THE HANDS CORRECTLY ON A CHRONOGRAPH

After the chronograph is repaired, assembled, and the dial replaced, the hands should be replaced as you would replace them on a regular watch. Do not replace the sweep second hand or the minute register hand at this time. Now push the button to force the flyback lever to return the seconds wheel and minute register wheel to zero. While the flyback lever is holding these wheels at a zero position, replace the minute register hand at 30 on the minute register track "C", and the sweep second hand at 60 on the split second track "B". The flyback lever can now be released. The chronograph should be engaged and let run for a period of time, then the hands returned to zero. This should be repeated several times to make sure that the chronograph hands consistently return to a zero position.