

▷ ROLEX DEEPSEA CHALLENGE
TO THE DEEPEST REACHES OF THE OCEANS





—	INTRODUCTION	3
—		
—		
—	AN EXPERIMENTAL DIVERS' WATCH	4
—		
—	PRESENTATION OF THE ROLEX DEEPSEA CHALLENGE	5
—		
—	TECHNICAL SPECIFICATIONS	7
—		
—	ROLEX AND THE DEEP	8
—		
—	COMPARISON OF THE DEEP SEA SPECIAL, ROLEX DEEPSEA AND ROLEX DEEPSEA CHALLENGE	11
—		
—		
—	BEHIND THE SCENES OF AN EXPLOIT	12
—		
—	THE MARIANA TRENCH	13
—		
—	1960–2012: FROM THE <i>TRIESTE</i> TO THE <i>DEEPSEA CHALLENGER</i>	14
—		
—	MAKING THE ROLEX DEEPSEA CHALLENGE: THE STORY	15
—		
—	THE DIVE	30

39370ft = 12000m

SUPERLATIVE CHRONOMETER
OFFICIALLY CERTIFIED



INTRODUCTION

10,908 METRES UNDER THE SEA

True to its passion for underwater exploration, Rolex took an active part in the historic *DEEPSEA CHALLENGE* expedition of film-maker and explorer James Cameron (*Titanic*, *Avatar*) in partnership with the National Geographic Society. On 26 March 2012, the expedition's submersible descended 10,908 metres (35,787 feet)* to reach Challenger Deep, the deepest point in the world's oceans located in the Mariana Trench, south-west of Guam in the Pacific Ocean. The *DEEPSEA CHALLENGER* carried an experimental divers' watch, the ROLEX DEEPSEA CHALLENGE, on its robotic manipulator arm. The timepiece worked perfectly throughout the dive at extreme pressures, confirming Rolex's position as the leading brand in waterproofness.

ECHOING THE HISTORIC DIVE OF 1960

Both James Cameron's expedition and the ROLEX DEEPSEA CHALLENGE directly echo the bathyscaphe *Trieste*'s historic dive on 23 January 1960, the first and until 2012 the only manned dive to the deepest-known point in the Mariana Trench. On that exploit, an experimental Oyster model, the DEEP SEA SPECIAL, was attached to the hull and accompanied the *Trieste* into the abyss. It reached the record depth of 10,916 metres (35,814 feet), returning to the surface in perfect working order, a feat that remained unrivalled for more than half a century.

James Cameron was thrilled at the additional opportunity to take a 1960 DEEP SEA SPECIAL with him in the cockpit of the *DEEPSEA CHALLENGER*: "As soon as I got into the sub, I found a special place to

attach the 'Old Lady', the sister of the watch that went down 52 years ago on the *Trieste*. She kept me company on the dive to the most remote place on this planet, and was my good luck charm."

A NATURAL PARTNERSHIP

Rolex was therefore a natural partner, with the National Geographic Society, for the *DEEPSEA CHALLENGE* expedition, a project that combined human adventure and technological innovation, the pursuit of excellence and pushed the limits of man's potential. Such endeavours correspond to the brand's core values and the philosophy inherited from its founder, Hans Wilsdorf. The *Trieste*'s dive in 1960 marked the culmination of Rolex's relationship with the underwater world. And the partnership with James Cameron's expedition marks a new and no less spectacular milestone in the history of the brand's privileged ties with the oceans. A history dating back to 1926 and the invention of the OYSTER, the world's first-ever waterproof wristwatch.

With this new achievement, the experimental ROLEX DEEPSEA CHALLENGE perpetuates the adventure of the OYSTER and the pioneering spirit of innovation that has forged the reputation of Rolex.

* The depth reading of 10,898 metres (35,756 feet) originally recorded on March 26, 2012 was scientifically corrected by the *DEEPSEA CHALLENGE* team to take into account variables such as latitude, water salinity and temperature.



AN EXPERIMENTAL DIVERS' WATCH

A ROLEX WATCH WAS ATTACHED TO THE MANIPULATOR ARM OF THE SUBMERSIBLE AS JAMES CAMERON MADE THE UNPRECEDENTED SOLO DIVE. THE OYSTER PERPETUAL ROLEX DEEPSEA CHALLENGE, AN EXPERIMENTAL DIVERS' WATCH, WAS SPECIALLY DEVELOPED, TESTED AND MANUFACTURED IN RECORD TIME FOR THE OCCASION. *"THE ROLEX DEEPSEA CHALLENGE WAS THE RELIABLE COMPANION THROUGHOUT THE DIVE; IT WAS VISIBLE ON THE SUB'S MANIPULATOR ARM AND WORKING PRECISELY 10,908 METRES DOWN AT THE BOTTOM OF CHALLENGER DEEP,"* JAMES CAMERON SAID AFTER HIS HISTORIC DIVE. *"IT'S A TREMENDOUS EXAMPLE OF ENGINEERING KNOW-HOW, AND AN IDEAL MATCH FOR THE DEEPSEA CHALLENGER SUBMERSIBLE."*



PRESENTATION OF THE DEEPSEA CHALLENGE

A WATCH FOR THE DEEPEST OF THE DEEP

The Oyster Perpetual ROLEX DEEPSEA CHALLENGE is an experimental divers' watch guaranteed waterproof to a depth of 12,000 metres (39,370 feet), entirely developed and manufactured by Rolex to resist the extreme pressure present in the deepest reaches of the oceans.

Through its inherent qualities, tested and proven in real life conditions during filmmaker and explorer James Cameron's dive, it is the emblematic product of an entirely integrated watchmaker with unparalleled design and production capacities.

BEYOND THE ABYSSAL DEPTHS

Technically, the ROLEX DEEPSEA CHALLENGE is an enhanced version of the commercial ROLEX DEEPSEA professional divers' watch (guaranteed waterproof to a depth of 3,900 metres or 12,800 feet) introduced in 2008. The new experimental watch is 51.4 mm in diameter and 28.5 mm thick. Its design is based on the RINGLOCK SYSTEM case architecture of the ROLEX DEEPSEA. This intricate three-piece case architecture, developed and patented by Rolex, features a highly resistant

nitrogen-alloyed stainless steel support ring as the backbone of the watch. Placed inside the middle case made of 904L stainless steel, it supports a 14.3 mm thick domed sapphire crystal, made of high-purity aluminium oxide, and a 5.3 mm screw-down case back made of grade 5 titanium.

IN THE WAKE OF THE ROLEX DEEPSEA

The ROLEX DEEPSEA CHALLENGE is fitted with a patented TRIPLOCK screw-down winding crown with a triple waterproofness system, the same type that equips all Rolex divers' watches. It also has other technical features of the ROLEX DEEPSEA, such as a unidirectional rotatable 60-minute graduated bezel with a CERACHROM insert in ceramic; a CHROMALIGHT display with long-lasting luminescence (hands and hour markers); a self-winding mechanical movement (calibre 3135) with a paramagnetic blue PARACHROM hairspring; and a solid-link OYSTER bracelet fitted with an OYSTERLOCK clasp with a safety catch and the Rolex GLIDELOCK and FLIPLock diving extension systems.

A TRUE ROLEX DIVERS' WATCH

The ROLEX DEEPSEA CHALLENGE is a true divers' watch, both technically and aesthetically a worthy member of the Rolex Oyster Professional family of watches. To comply with the stringent certification requirements for divers' watches, the watch was tested by Rolex in a specially created hyperbaric tank at a pressure of 1,500 bars, corresponding to the pressure at a depth of 15,000 metres (nearly 50,000 feet), 25 per cent greater than the depth to which the watch is guaranteed waterproof. At a depth of 15,000 metres, the load exerted on the crystal is 17 tonnes (13.6 tonnes at 12,000 metres), and on the case back nearly 23 tonnes; a total of some 40 tonnes is borne by the support ring in the middle case.

A SYMBOL OF SUPREMACY

The ROLEX DEEPSEA CHALLENGE symbolizes the brand's supremacy in mastering water-proofness. Its spirit and the real-life circumstances for which it was developed echo the approach adopted for the Rolex experimental DEEP SEA SPECIAL model, which in 1960 accompanied the bathyscaphe *Trieste* on its record descent to a depth of 10,916 metres (35,814 feet) at the bottom of the Mariana Trench.

PERPETUATING A PIONEERING SPIRIT

The ROLEX DEEPSEA CHALLENGE embodies the heritage and technical and watchmaking know-how of a pioneering brand in wristwatches. This status is enshrined in Rolex's invention in 1926 of the OYSTER, the first ever waterproof wristwatch, and demonstrated by all the divers' watches, such as the SUBMARINER and the SEA-DWELLER, launched by the brand since the 1950s.

ADVENTURE AND TECHNOLOGY

This watch bears witness in a spectacular way to the privileged ties that bind Rolex to exploration in general and to the underwater world in particular. The ROLEX DEEPSEA CHALLENGE perpetuates a story that combines human adventure and technology, innovation and the constant pursuit of excellence. An adventure punctuated with exceptional moments, some of which have entered the annals of history, when Rolex watches have proven their mettle under extreme conditions by accompanying men and women in their quest for the absolute.





ROLEX DEEPSEA CHALLENGE

TECHNICAL SPECIFICATIONS

CATEGORY	Experimental watch
CASE	OYSTER (monobloc middle case, screw-down case back and winding crown)
DIAMETER	51.4 mm
THICKNESS	28.5 mm
ARCHITECTURE	RINGLOCK SYSTEM with a nitrogen-alloyed stainless steel support ring
MATERIALS	904L steel, case back in grade 5 titanium
WINDING CROWN	Screw-down, TRIPLOCK triple waterproofness system
CROWN GUARD	Integral part of the middle case
CRYSTAL	Domed synthetic sapphire, 14.3 mm thick
BEZEL	Unidirectional rotatable 60-minute graduated; CERACHROM insert in ceramic with numerals and graduations coated in platinum via PVD
DIAL	Black lacquer, CHROMALIGHT display with long-lasting luminescence
WATERPROOFNESS	12,000 m (39,370 ft)
MOVEMENT	Calibre 3135, <i>Manufacture Rolex</i> Mechanical movement with bidirectional self-winding via PERPETUAL rotor
FUNCTIONS	Centre hour, minute and seconds hands. Instantaneous date with rapid setting. Stop seconds for precise time setting
FREQUENCY	28,800 beats/hour (4 Hz)
PRECISION	Officially certified Swiss chronometer (COSC) Paramagnetic blue PARACHROM hairspring with Rolex overcoil Large balance wheel with variable inertia High-precision regulating via gold MICROSTELLA nuts
POWER RESERVE	Approximately 48 hours
BRACELET	OYSTER; folding OYSTERLOCK safety clasp with GLIDELOCK system for fine adjustment of bracelet length, FLIPLock extension link

ROLEX AND THE DEEP

A PASSION FOR EXPLORATION

In 1960, Rolex made watchmaking history when it joined the bathyscaphe *Trieste*, crewed by Swiss oceanographer Jacques Piccard and the then U.S. Navy Lieutenant Don Walsh, as the Swiss-designed bathyscaphe descended to the deepest-known point in the ocean.

An experimental Rolex DEEP SEA SPECIAL wristwatch was attached to the exterior of the *Trieste* when it touched the bottom of the Mariana Trench in the Pacific Ocean on 23 January 1960, reaching a depth of 10,916 metres (35,814 feet). It successfully withstood tremendous pressure that no submersible, let alone watch, had confronted before and that no human could ever survive. The dive marked the culmination of a long association with Jacques Piccard and his father Auguste Piccard, the inventor of the bathyscaphe, as they stretched the boundaries of deep-sea exploration. It was also the fruit of decades of unrelenting development of the waterproof wristwatch, which was invented by Rolex.

A HISTORY OF DISCOVERY

Rolex has always been associated with exploration of the planet's most extreme frontiers and pushing the limits of human endeavour, in keeping with the spirit instilled by its founder, Hans Wilsdorf. He actively led the company through the most adventurous decades of the 20th century, a period marked by discovery of the world

about us and immense technological progress. The Swiss watchmaker has, in particular, nurtured a special relationship with the sea and its deepest reaches from its very beginnings. With the National Geographic Society, Rolex is simply the natural partner for *DEEPSEA CHALLENGE*, a scientific expedition that heralds the beginning of a new era in marine exploration.

Robust, precise and highly reliable Rolex OYSTER watches have not only accompanied the *Trieste* on the world's deepest dive. They also equipped the expedition by Sir John Hunt, Sir Edmund Hillary and Tenzing Norgay to the top of the world in 1953 – leading to the pioneering ascent of Mount Everest.

The Piccards, Don Walsh and their bathyscaphe followed in the steps of those adventurers, providing the ultimate test for Rolex technology and the experimental DEEP SEA SPECIAL watch. After the *Trieste* surfaced from its record dive in 1960, a cable was sent to Rolex headquarters:



“HAPPY ANNOUNCE TO YOU YOUR WATCH
AS PRECISE AT 11,000 METRES AS ON SURFACE.
BEST REGARDS JACQUES PICCARD”

24 January 1960

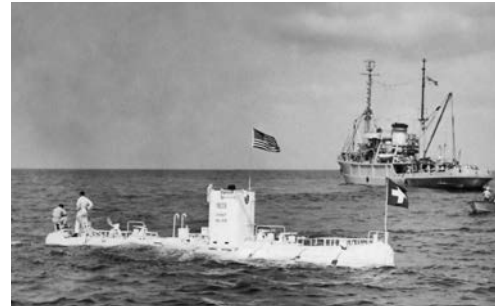

The bathyscaphe *Trieste* (above). / Jacques Piccard in 1960 (below).

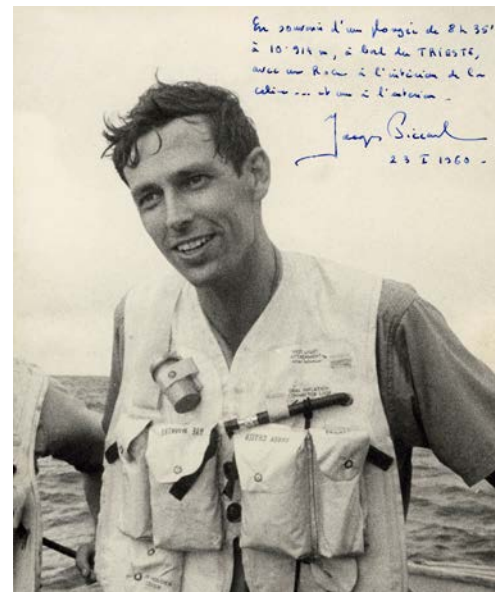

Sir Edmund Hillary and Tenzing Norgay headed for the top of the world in 1953.

Rolex has also sustained and extended its position at the forefront of watchmaking for diving and underwater research with ground-breaking innovations.

A PROVING GROUND

Exploits of the kind have also provided a proving ground for Oyster wristwatches from the very beginning. Rolex is in its element in water, and the name chosen for its iconic collection of waterproof wristwatches is no accident.

Waterproofness was a fundamental feature that helped to make the wristwatch reliable and accurate. Rolex invented the first waterproof wristwatch in 1926, and provided a real-life demonstration of its waterproofness when Mercedes Gleitze swam the English Channel wearing one a year later. The Oyster watch innovated with its screw-down case back, bezel and winding crown, forming the essence of the modern-day sealed case that protects a high-precision movement. Such reliable waterproofness is today inherent in every Rolex Oyster Perpetual model.

TOOLS OF THE TRADE

During the 1940s and 1950s, developments in diving technology paved the way for a boom in underwater exploration. The exacting professional diving community came to treasure Rolex watches as essential tools of the trade and even helped in their development.

The iconic Oyster Perpetual SUBMARINER, first unveiled in 1953, is today waterproof to a depth of 300 metres (1,000 feet). The SEA-DWELLER model, first presented in 1967 extended the depth limit for Rolex waterproof watches to 610 metres (2,000 feet) then 1,220 metres (4,000 feet) in 1978.

And ultimately the ROLEX DEEPSEA, introduced in 2008, illustrates the supremacy of Rolex in mastering waterproofness. This new-generation divers' watch is waterproof to a depth of 3,900 metres (12,800 feet), providing a substantial safety margin for those working in the open water at great depth. Each ROLEX DEEPSEA is individually tested in a specially built hyperbaric tank in Geneva.



The ROLEX DEEPSEA illustrates the supremacy of Rolex in waterproof wristwatches.

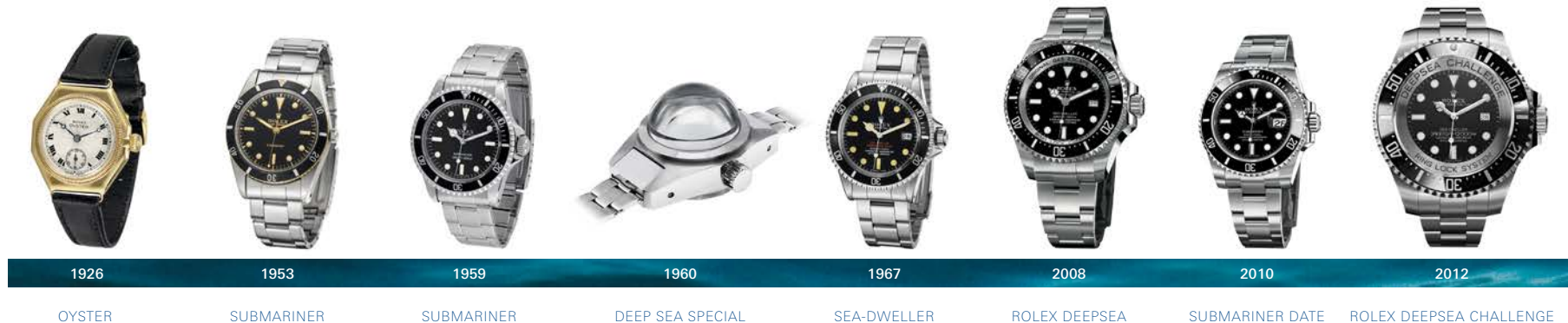



Don Walsh, *Trieste* pilot, next to a model of the bathyscaphe and James Cameron, holding 1960 DEEP SEA SPECIAL and a 2012 ROLEX DEEPSEA CHALLENGE respectively.



James Cameron, wearing his ROLEX DEEPSEA, emerges from the DEEPSEA CHALLENGER after the historic solo dive.

HARNESSING TECHNOLOGY

The test tank for the ROLEX DEEPSEA was developed with specialist engineers from COMEX (Compagnie Maritime d'Expertises), a world-renowned French company specializing in underwater engineering and hyperbaric technologies. Rolex has been collaborating with COMEX for decades and supplied watches to equip its elite divers.

Timepieces such as the ROLEX DEEPSEA and the state-of-the-art, experimental ROLEX DEEPSEA CHALLENGE carried by James Cameron's submersible are the product of nearly a century of finely tuned know-how and innovation. They attest to the pursuit of perfection and the finest engineering.

Nonetheless, Rolex's affinity with the deep does not stop there. It extends to active and sustained sponsorship of renowned marine researchers and ocean exploration, supporting excellence in the advancement of human knowledge.

OUR FRIENDS

Don Walsh remains part of the Rolex family, while Rolex Testimonees include renowned oceanographer and explorer Sylvia Earle as well as underwater photographer and marine naturalist David Doubilet. Rolex was associated with *The Deep*, an exceptional exhibition of deep-sea creatures conceived by film-maker Claire Nouvian in collaboration with scientific researchers, providing visitors with a unique opportunity to discover some of the mysteries of the Earth's largest reservoir of life. Rolex supports the Our World – Underwater Scholarship Society, funding young Rolex Scholars to gain hands-on experience with leaders in marine-related research including on scientific expeditions.

In the same vein, James Cameron's DEEPSEA CHALLENGE, with the National Geographic Society and Rolex as partners, took us on a new journey to the deepest frontier accessible to mankind, shedding light on secrets held by the ocean floor for centuries.

DOUBLE HERITAGE

COMPARISON OF THE DEEP SEA SPECIAL, ROLEX DEEPSEA AND ROLEX DEEPSEA CHALLENGE

The ROLEX DEEPSEA CHALLENGE enjoys a double heritage. In historical terms, it is the heir of the 1960 experimental Oyster DEEPSEA SPECIAL, which dived to the bottom of the Mariana Trench with the bathyscaphe *Trieste*.

Technically and aesthetically, it is an enhanced version of the commercial ROLEX DEEPSEA, launched in 2008 and guaranteed waterproof to a depth of 3,900 metres (12,800 feet). The RINGLOCK SYSTEM architecture developed and patented by Rolex for this new-generation professional divers' watch has also been used for the ROLEX DEEPSEA CHALLENGE model.

DEEP SEA SPECIAL
1960



ROLEX DEEPSEA
2008

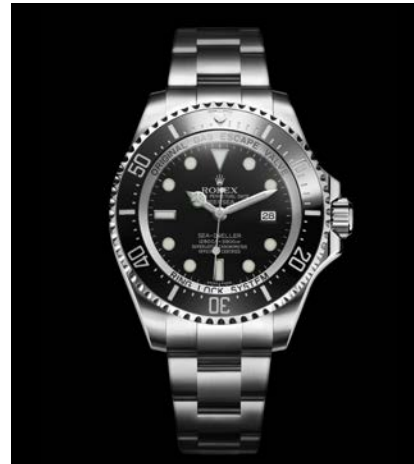

ROLEX DEEPSEA CHALLENGE
2012



TYPE	Experimental watch	Professional watch	Experimental watch
WATERPROOFNESS	10,916 m 35,814 ft	3,900 m 12,800 ft	12,000 m 39,370 ft
LOAD RESISTANCE	—	3.1 tonnes	13.6 tonnes
DIAMETER	42.7 mm	44 mm	51.4 mm
THICKNESS	36 mm	17.7 mm	28.5 mm
CASE	OYSTER	OYSTER + RINGLOCK SYSTEM	OYSTER + RINGLOCK SYSTEM
MATERIALS	Steel	904L steel (middle case). Nitrogen-alloyed steel. Grade 5 titanium (case back)	904L steel (middle case). Nitrogen-alloyed steel. Grade 5 titanium (case back)
CRYSTAL THICKNESS	Plexiglas 18 mm	Sapphire 5.5 mm	Sapphire 14.3 mm
CROWN	OYSTER (double waterproofness)	TRIPLOCK (triple waterproofness)	TRIPLOCK (triple waterproofness)
MOVEMENT	1570, self-winding mechanical	3135, self-winding mechanical	3135, self-winding mechanical



BEHIND THE SCENES OF AN EXPLOIT

THE OYSTER PERPETUAL ROLEX DEEPSEA CHALLENGE WAS DESIGNED AND MANUFACTURED IN RECORD TIME TO ACCOMPANY FILM-MAKER AND EXPLORER JAMES CAMERON ON HIS EXPEDITION TO THE DEEPEST POINT IN THE OCEAN: CHALLENGER DEEP IN THE MARIANA TRENCH. THE STORY BEHIND THE MAKING OF THIS EXPERIMENTAL DIVERS' WATCH STARTS AND FINISHES AT ROLEX HEADQUARTERS IN SWITZERLAND, WHERE THE KNOW-HOW OF ROLEX AND THE EXPERTISE OF A HIGHLY SPECIALIZED TEAM WERE PUT TO THE TEST — AND PROVEN SUCCESSFUL — IN YET ANOTHER PIONEERING EXPLOIT.

THE MARIANA TRENCH

AT THE BOTTOM OF THE OCEAN



The Mariana Trench, which stretches in an arc around the Mariana Islands in the Pacific Ocean, is the deepest part of the world's oceans. The deepest point in the trench, known as Challenger Deep, lies some 11,000 metres (nearly 7 miles) below the surface. If Mount Everest, the world's tallest peak, were set in the trench, there would still be approximately 2,000 metres (1.3 miles) of water above it. The

trench was created by subduction, the downward movement of Pacific tectonic plate beneath the Mariana Plate.

Challenger Deep was named after the 1858 British Royal Navy Ship *HMS Challenger*, the first vessel to sound the depths of the trench.

In January 1960, Swiss oceanographer Jacques Piccard and the then Lieutenant Don Walsh manned the 150-tonne U.S. Navy bathyscaphe *Trieste* for the journey to Challenger Deep and back. Between then and James Cameron's expedition in 2012, only unmanned vessels had descended to such depths.

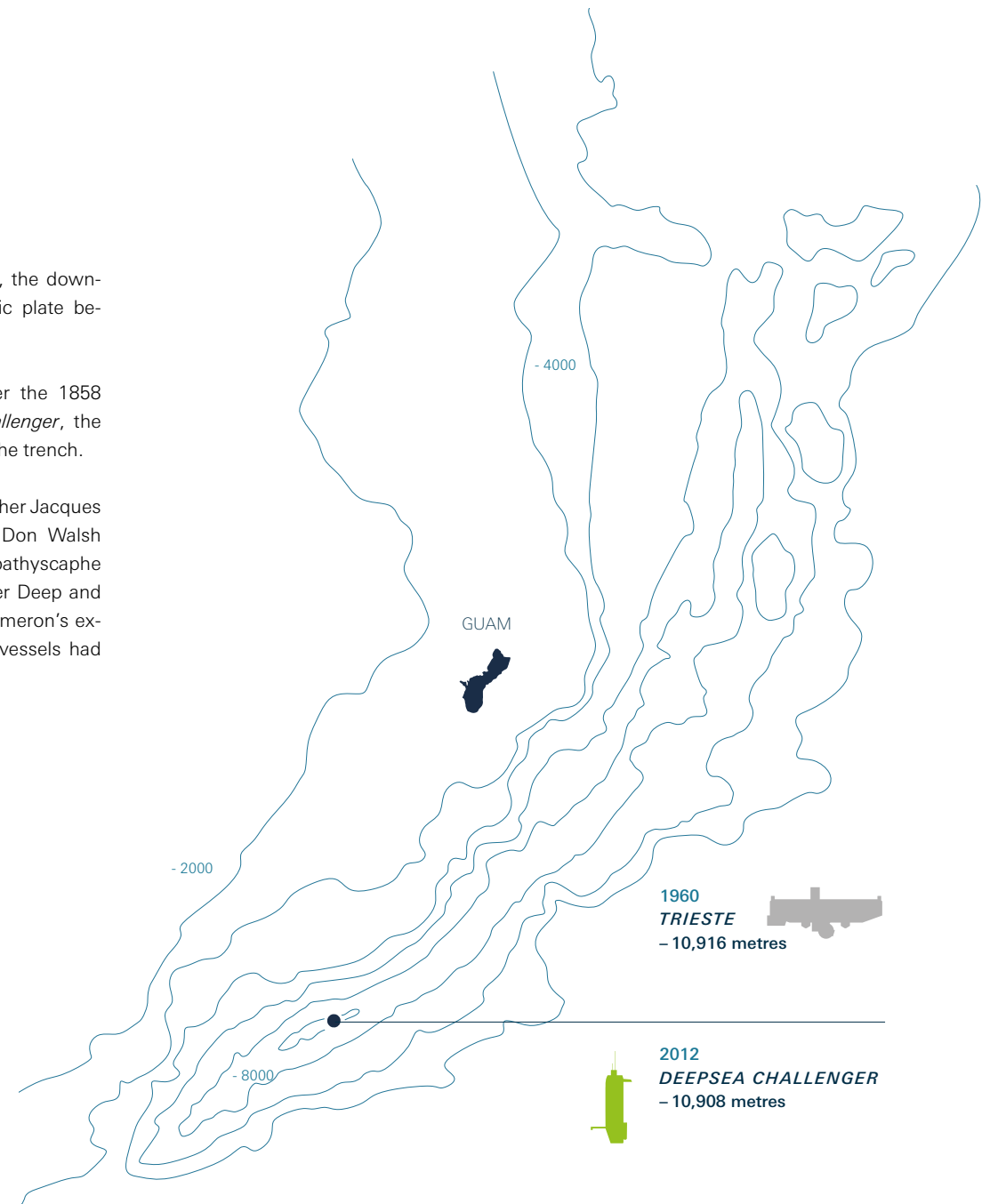
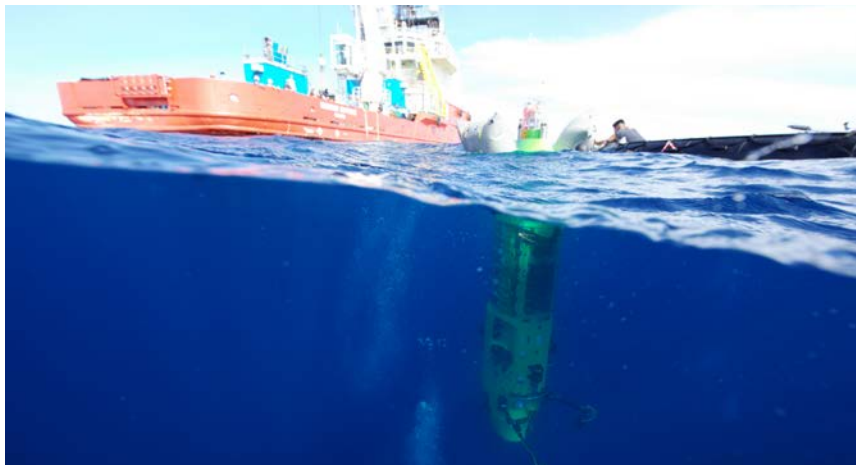

THE SUBMARINES

1960–2012 FROM THE *TRIESTE* TO THE *DEEPSEA CHALLENGER*

1960 – *TRIESTE*

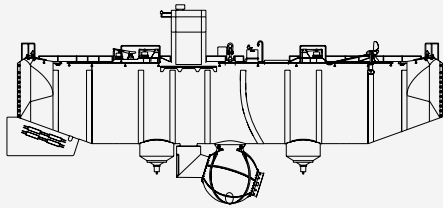

THE BATHYSCAPHE

18.1 m (59.5 ft) long, oriented horizontally

Weight: 150 tonnes

Buoyancy provided by gasoline tanks

No technology to collect samples or specimens

No external technology to take photographs

THE DIVE

Naval expedition

Two-person

Depth reached: 10,916 m (35,814 ft)

Dive time: About 9 hours including 20 minutes at the bottom

Observation of deep-sea life forms

THE WATCH

Rolex DEEP SEA SPECIAL experimental watch

Waterproof to 10,916 m (35,814 ft)

Attached to the exterior of the bathyscaphe

Diameter: 42.7 mm

Thickness: 36 mm

2012 – *DEEPSEA CHALLENGER*

THE SUBMERSIBLE

7.3 m (24 ft) tall, "vertical torpedo" shape

Weight: 12 tonnes

Buoyancy provided by ISOFLOAT™ syntactic foam

Designed as a science platform, with manipulator arm, core sampler and sample drawer to collect samples for research in marine biology, microbiology, oceanography, marine geology and geophysics

Equipped with multiple 3D film and still cameras for scientific observation and film production

THE DIVE

Scientific expedition

One-person

Depth reached: 10,908 m (35,787 ft)

Dive time: 6 hours and 45 minutes including about 3 hours at the bottom

Collection of samples; filming and photography

THE WATCH

ROLEX DEEPSEA CHALLENGE experimental watch

Waterproof to 12,000 m (39,370 ft)

Attached to the submersible's manipulator arm

Diameter: 51.4 mm

Thickness: 28.5 mm

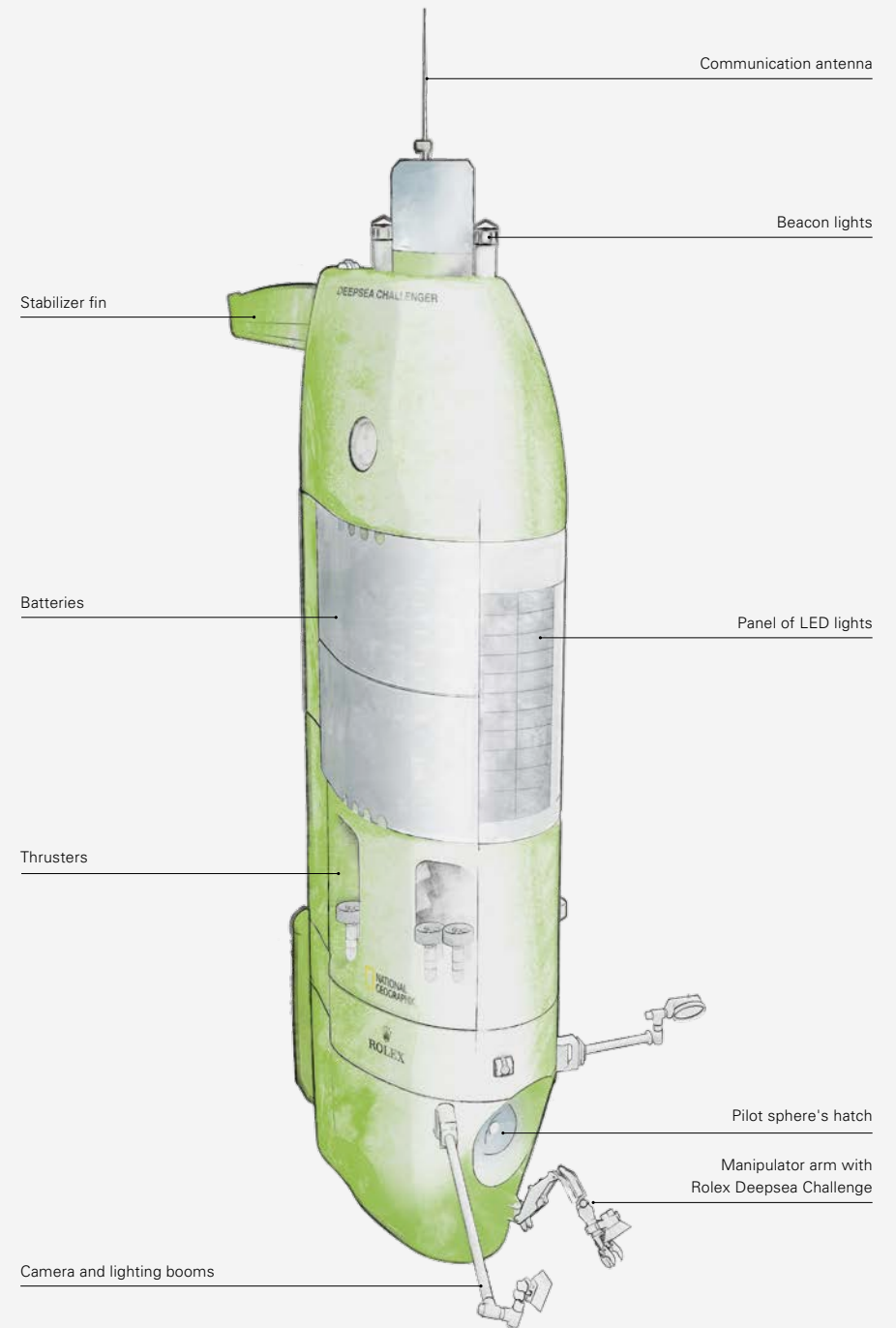

MID 2011

MAKING THE ROLEX DEEPSEA CHALLENGE: THE STORY

Making a watch that could successfully dive to the deepest point in the world's oceans? Only Rolex had managed this. In 1960, an experimental OYSTER, the DEEP SEA SPECIAL, attached to exterior of the bathyscaphe *Trieste*, reached the record depth of 10,916 metres (35,814 feet) in the Pacific Ocean. Since this dive by Swiss oceanographer Jacques Piccard and US Navy Lieutenant Don Walsh, the pilots of the *Trieste*, no one had returned to the bottom of Challenger Deep, the deepest point on the planet, located in the Mariana Trench.

For more than half a century, the Rolex DEEP SEA SPECIAL remained the only watch to be tested at the deepest ocean floor in real life conditions.

The DEEP SEA SPECIAL watch was attached to the exterior of the *Trieste*.



NEW ERA IN MARINE EXPLORATION

The year 2011 saw renewed interest in exploration of the ultimate deep frontier. Several rival projects aimed not only to descend to the very bottom of the Mariana Trench, but also to explore and film this virtually unknown universe. One of the most advanced was James Cameron's expedition, *DEEPSEA CHALLENGE*. For Rolex, active participation in this new era of underwater exploration was an obvious choice.

For more than half a century, the Rolex DEEP SEA SPECIAL remained the only watch to be tested at the deepest point in real life conditions.



▷ 10,916 metres



PRELIMINARY STUDY

In mid-2011, Rolex launched a preliminary study into an experimental model which would be waterproof to a depth of 12,000 metres (39,370 feet). Several days of intensive calculations and modelling confirmed the feasibility of such a watch based on the technology of the ROLEX DEEPSEA (waterproof to 3,900 metres – 12,800 feet), notably the RINGLOCK System case architecture patented by Rolex. This system consists of an OYSTER case with a screw-down back and winding crown, reinforced by a high-performance compression ring in nitrogen-alloyed steel inside the middle case. The crystal and the case back rest on this ring, offering extremely high resistance in a relatively compact case.

RAW MATERIALS IN STOCK

To complete the feasibility study, a check was made to ensure that the raw materials (904L steel, nitrogen-alloyed steel and grade 5 titanium) needed to manufacture such an exceptional experimental watch were available in stock. By early February 2012, when Rolex decided to commit to James Cameron's project, this preparatory work proved decisive. It demonstrated the brand's capacity to anticipate future needs.

UNIQUE TANK FOR EXTREME TESTS

Another key decision, taken years earlier, proved to be crucial for the project's success. In 2004, during the development of the ROLEX DEEPSEA, the idea of acquiring a special hyperbaric tank took hold. It would have to be capable of testing watches to a guaranteed water-resistance depth of 12,000 metres – deeper than the deepest ocean floor. This unique tank, the only one of its kind in the world, was quickly baptized "Mariannes" (Mariana). Watches could be tested at pressures of up to 1,500 bars (corresponding to a depth of 15,000 metres: 12,000 metres + a 25 per cent safety margin), so that they could be certified as divers' watches in keeping with official standards.

When Rolex joined the *DEEPSEA CHALLENGE* expedition in 2012, in partnership with the National Geographic Society, all the human and technological resources needed to design, manufacture and test a divers' watch guaranteed waterproof to a depth of 12,000 metres were at hand.



Ideally, six months were needed to complete the task; however, only four weeks remained before James Cameron's dive to the deepest reaches of the ocean. For everyone involved in the confidential project, it marked the beginning of a daunting race against time...



EARLY FEBRUARY

AN ENGINEERING CHALLENGE

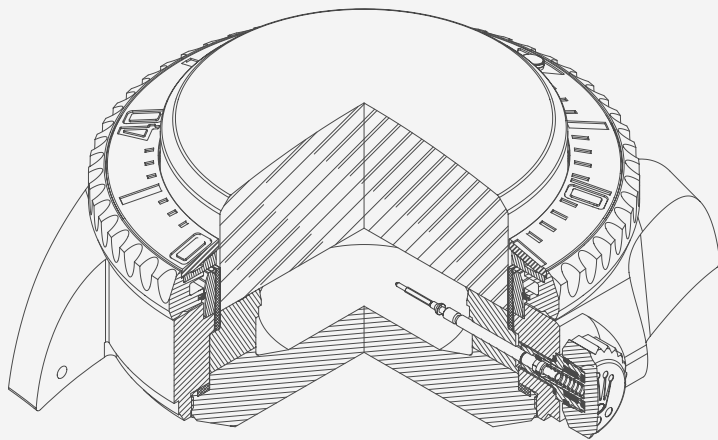

The major challenge of a dive so deep is the extreme water pressure. At 10.9 km below the surface, the pressure is equivalent to over one tonne per cm², or six SUVs piled on the watch.

Theoretically, a ROLEX DEEPSEA could be overengineered to withstand a depth of 12,000 metres – as confirmed by the preliminary study. When the design engineer who had conducted the study was informed that the project was a priority, he returned to the results of his calculations. He also enlisted two other design engineers who had acquired significant expertise from working on the development of the ROLEX DEEPSEA case.

Speed was of the essence, it was crucial to profit from their know-how and experience with calculations, modelling, simulation and their mastery of the prototype process. Given the

deadlines, they had to succeed at the first attempt. The project became priority number one and all those involved were mobilized full-time. For several weeks, a substantial part of the research and development staff were solicited for the Deepsea Challenge venture.

MODELLING AND SIMULATION

After validation of the preliminary calculations, the design engineers began precise modelling of the new watch and tested the results using computer simulation, first testing the stress exerted by the pressure on the case architecture as a whole, then component by component. They spent an entire week, 12 hours a day, on it. The technical dimensioning of the watch took shape in cycles, through a process of repeated simulations and successive corrections. The right compromise had to be found: increasing the size of the case components would bring greater robustness but greater stress as well. The water pressure exerted on the watch would increase in proportion to its surface area.

CRITICAL COMPONENTS

The crystal is at the very top of the list of critical components due to its production lead time. Since a block of synthetic sapphire of the quality used for the ROLEX DEEPSEA takes approximately two months to make, the project could simply not be completed within the timeframe required if the material were not at hand.

According to the first calculations for the dimensions of the crystal, a thickness of 14 mm would be required to resist the shock of the 1,500-bar pressure test – the equivalent of 17 tonnes on its surface. Fortunately, the raw material was available in a thickness of 15 mm. But, the exact specifications of the crystal were needed very quickly in order to deliver it within the one-week deadline. Briefed in the morning, the design engineers were able to come up with the dimensions the same evening, after an intense day of work on calculations and modelling.

Computer model of the pressure exerted on the watch at 15,000 metres. The scale of stress levels ranges from near zero in blue to the maximum in red. The pressure on the crystal and on the case back, which is borne by the Ringlock compression ring, is shown in blue and green.

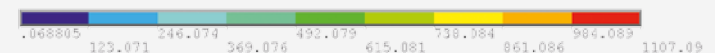
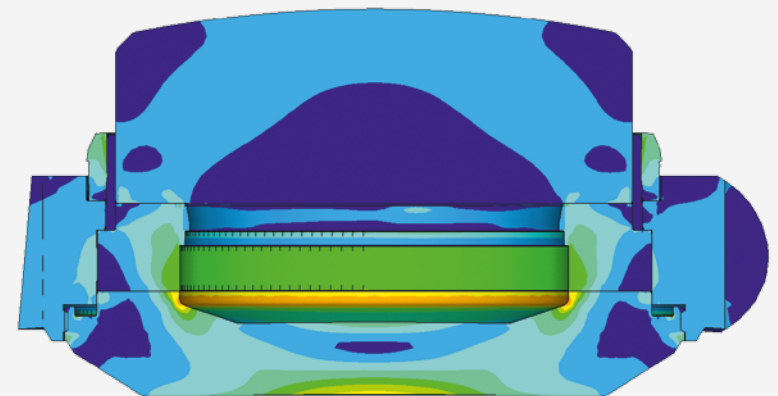

TECHNICAL DIMENSIONING

Basing themselves on the very same diameter of the movement and dial of the ROLEX DEEPSEA, the design engineers calculated the outer diameter of the new nitrogen-alloyed steel compression ring for the RINGLOCK System and the width of its bearing surfaces, on which the crystal and case back would rest. This width determined the diameters of the crystal, of the titanium case back and of the 51.4-mm middle case. The design engineers concentrated on the technical characteristics of the heart of the piece, comprising the support ring, the crystal and the case back, which together ensure water and pressure resistance, as well as the crown. The rest of the case and bracelet, including the middle case and rotatable bezel, was rescaled from the ROLEX DEEPSEA.

The result was technically accomplished, but required some aesthetic adjustments that would transform an engineering concept into a watch worthy of the Rolex Oyster collection.



The designer worked swiftly to adjust the aesthetics of the watch and create its markings.



10 FEBRUARY EXPRESS DESIGN

When one of Rolex's designers received a telephone call one morning from the head of Research, he had no idea of the adventure that awaited him. He was asked to drop everything and come immediately. Since the project was highly confidential, all communication was kept to a minimum. The designer was simply informed that he was to make a few aesthetic corrections to a "somewhat special" piece. He then went to meet with the case design engineers. When they showed him their 3D model on the screen, the designer was shocked at the "unusual" proportions of the object before him and by the timeframe he was given: just half a day to readjust the appearance of the case and another half a day to design the markings and engravings on the dial and the flange.

DEEPSEA AESTHETICS

The designer began work immediately, looking at the design engineers' computer screen. They introduced his suggestions directly onto their 3D model. No time to lose. And no question of touching the technical characteristics of the components, notably the inordinate thickness of the crystal. To give the piece more harmonious proportions, the designer adapted

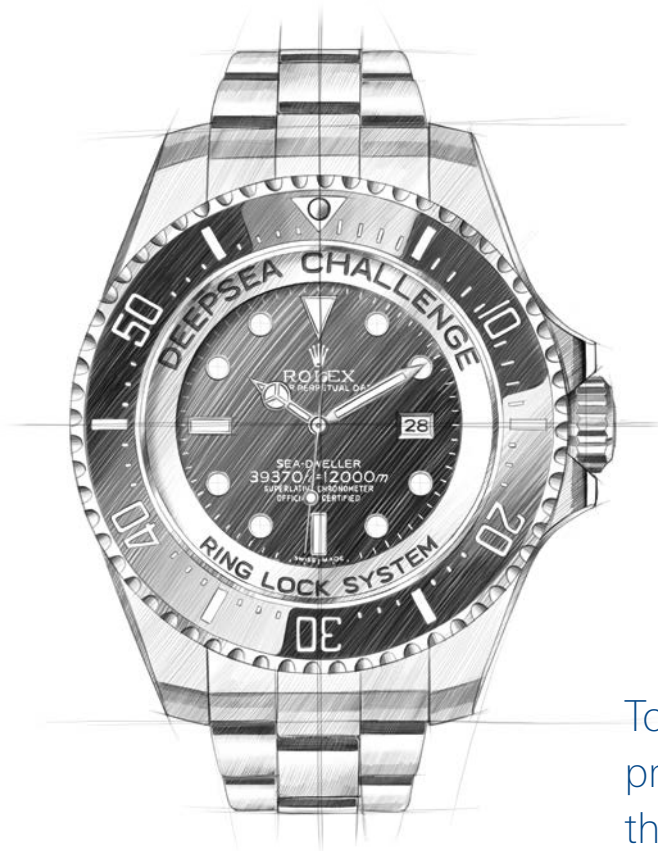

the thickness of the middle case and the rotatable bezel to cover a larger portion of the crystal. He also convinced the design engineers to slightly modify the domed aspect of the crystal while adding a bevel to its edge in order to soften its appearance. The height of the case back was increased by a few millimetres, enough to visually balance the apparent thickness of the middle case.

BIRTH OF A WATCH

The proportions of the Triplock winding crown were also adjusted: the ROLEX DEEPSEA winding crown with a diameter of 8 mm was sufficient in technical terms, but seemed too

small on an oversized middle case. Its diameter was increased to 10 mm to complement the adjustments to the proportions of the crown guard. The shape of the lugs was also adapted to allow the attachment of a wider and thicker bracelet. By noon, the 3D model had been transformed as far as possible into a watch.

ZERO RISK

With a zero per cent margin of error and very tight timing, the designer and the design engineers kept to tried and tested solutions. Once the plans were finalized after a three-day rush, the prototype unit would have to manufacture the watches part by part.



To give the piece more harmonious proportions, the designer adapted the thickness of the middle case and the rotatable bezel to cover a larger portion of the crystal.

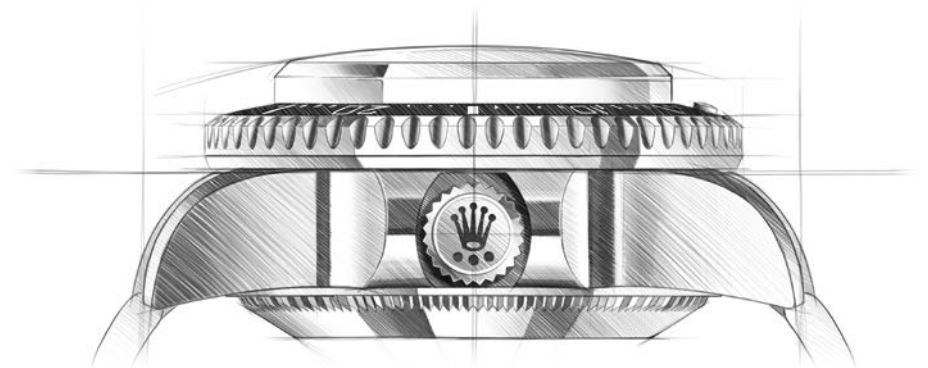

11 FEBRUARY

A WATCH NAMED ROLEX DEEPSEA CHALLENGE



deep divers' watches, whose origins date back to 1967. However, the ROLEX DEEPSEA CHALLENGE was not equipped with a helium valve, seeing as it was not intended to equip divers. It would not be subjected to decompression phases in hyperbaric chambers – so a helium valve would be superfluous on James Cameron's dive. The inscription "Original Gas Escape Valve", engraved at 12 o'clock on the flange of the ROLEX DEEPSEA, was replaced by the laser-engraved name of the experimental watch, "Deepsea Challenge". The choice of the watch's name will probably remain the only part of the project for which time was not a major challenge.



The choice was obvious and a high-level meeting decided on the name in less than 15 minutes.

Once the project was launched, the experimental watch needed a name. The choice was obvious, and the members of a high-level meeting decided on the name in less than 15 minutes. It would be baptized ROLEX DEEPSEA CHALLENGE in tribute to its three-fold heritage. The designation alludes to the name of James Cameron's project; to the 1960 Deep Sea

Special model, which had accompanied the *Trieste*; and finally to the 2008 ROLEX DEEPSEA, the watch's conceptual, technical and aesthetic ancestor.

The markings on the dial of the ROLEX DEEPSEA CHALLENGE deliberately highlight the watch's family ties with the SEA-DWELLER

13 TO 17 FEBRUARY

ART AND MATTER

Exceptional watch, exceptional components. Even before manufacturing issues came into play, the inordinate size of the ROLEX DEEPSEA CHALLENGE's case represented a challenge in terms of raw materials and small parts. The plans had barely been finalized when the three design engineers took charge of all the supply and manufacturing aspects of the watch. They began by listing the critical components in order to check on their availability.



The grade 5 titanium case back was specially made for the experimental watch.

METAL IN STOCK

The preliminary study in 2011 had established the availability of the strategically important metal bars: 904L steel for the middle case and bracelet, high performance nitrogen-alloyed steel for the RINGLOCK System ring, grade 5 titanium for the case back. The prototype workshop is a true miniature manufacturing plant; out of these raw materials, it was ready to produce all the metal parts from scratch with an impeccable finish. As for the movement, dial and hands, the standard components of the ROLEX DEEPSEA were used – with ad hoc adjustments to the dial design.

The first sapphire crystals were ready within one week and were immediately tested at 1,500 bars in the "Mariannes" tank. For the design engineers, this was the moment of truth: if the crystals held, the watches would hold. Verdict: of the 10 crystals tested, only one cracked under the pressure due to an imperfection in its mounting. The tests proved the accuracy of the calculations and the technical expertise of the watchmakers.



For the design engineers, this was the moment of truth: if the crystals held, the watches would hold.

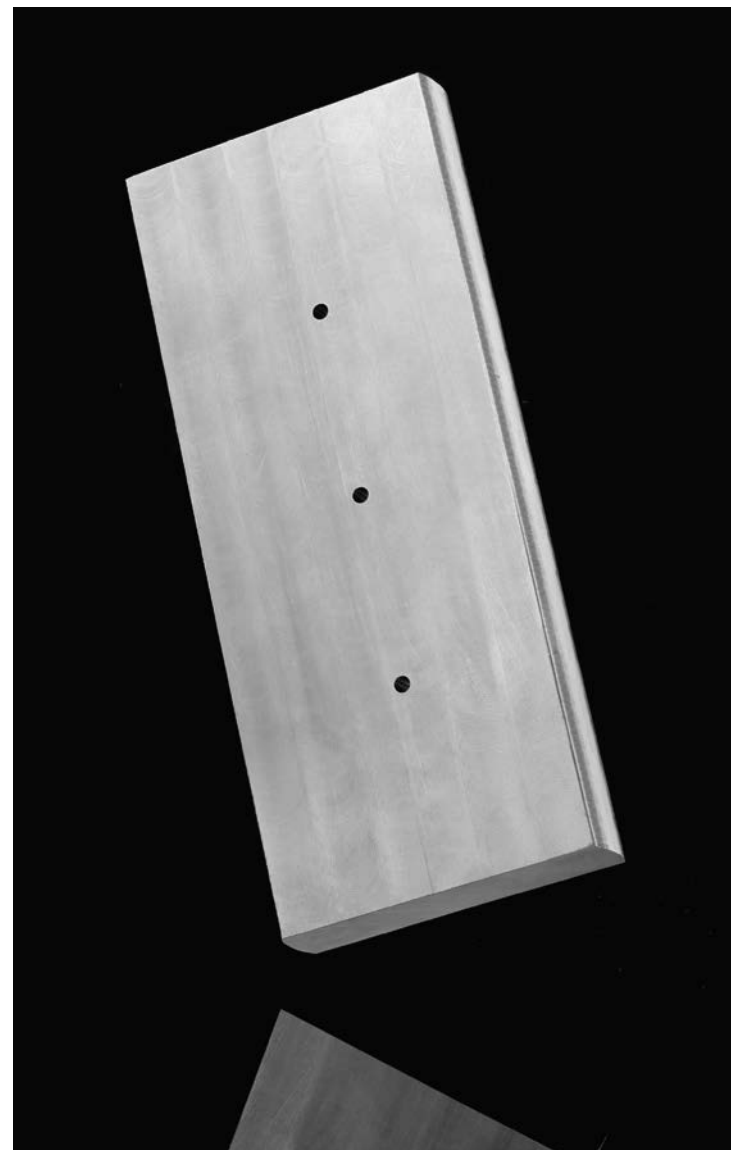

Rolled plate of 904L steel used to craft the middle cases.

QUICK THINKING

Another challenge awaited the design engineers: while a large rod of 904L steel was indeed in stock in the prototype workshop, its diameter was not sufficient to craft the middle cases of the ROLEX DEEPSEA Challenge watches in the usual manner. The prototype experts approached the problem from another angle and conjured up a solution. They decided to cut the 904L steel rod lengthwise to obtain a rolled plate. This provided a large enough surface area to craft the middle cases.

Such inventiveness was also required to make the tools and fittings that did not already exist. The ROLEX DEEPSEA CHALLENGE design engineers, who had established the dimensions for all the components, would devote a lot of time to this during two intense weeks of follow-up work. In the end, they would design more tools than components for this experimental model. The plans for the tools and supports were transmitted to the prototype experts, who used the full array of machines at their disposal to create them. Many of the supports were made using Rolex's state-of-the-art technology and equipment, incorporating avant-garde processes that save precious time in the manufacture of custom-made tooling.

The watch was designed, the plans were in place. Now it was time to fashion each component from the raw material. Extreme precision was needed in order to guarantee the extraordinary waterproofness and robustness of this unique case.

Extreme precision was needed in order to guarantee the extraordinary waterproofness and robustness of this unique case.

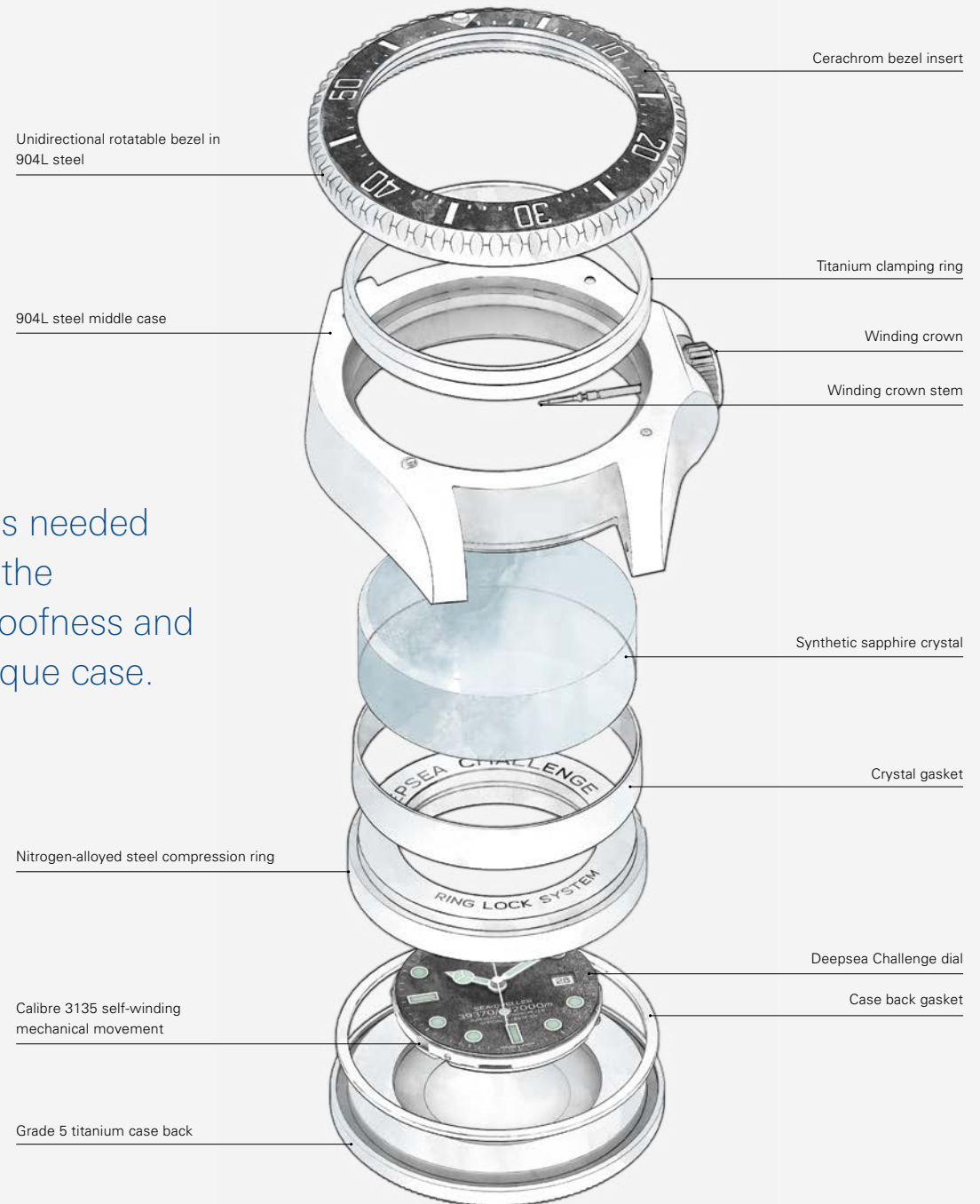

13 FEBRUARY TO 2 MARCH

MANUFACTURING WORKSHOP

While the case and bracelet of the ROLEX DEEPSEA CHALLENGE were designed at the Rolex industrial production facility, they were manufactured at the brand's prototype workshops.

It is hard to imagine two more distinct worlds than this highly specialized workshop, a true miniature manufacturing plant, and the industrial production facility. In the latter, entire floors of large-capacity machines carry out well-established operational sequences to make finished products in large quantities. At the prototype workshop, on the other hand, custom-made items are produced one by one, creating parts and complete

components from raw materials. Here, the key words are reactivity and flexibility.

TEAM WORK

About 25 people work in the prototype workshop – methodologists, programmers and CNC machine set-up experts, machine operators, polishers, assemblers. Even though they are used to working on secret and urgent projects for research and development, the project that the three design engineers came to present to them in the second week of February was really out of the ordinary. They quickly converted the technical plans into a sequence of manufacturing operations.

Early Monday morning, the workshop supervisors wrote out a schedule on a big board: operations to be completed, machines to be used, target dates, responsibilities. No choice, the deadlines must be met. It was not simply a question of making one watch, but six watches – to be sure to have at least five watches for the dive, plus one watch that would be reserved for communication purposes only. The workshop also had to make a number of special tools and supports. All this, in just three weeks. Fortunately, some machine operations could continue running overnight.

PARALLEL MANUFACTURING

The components had barely passed through one operation when they were sent on to the next. All the metal parts of the case were made by the prototype experts: the middle case, case back, RINGLOCK ring, rotatable bezel, clamping ring, winding crown and its tube. One by one, the finished components were passed on for polishing by a dedicated cell of the workshop, then all the case components were carefully assembled, still by the prototype experts.



Left: a 904L steel blank for the watch cases is ready for machining.

Middle: fine cutting by electrical discharge machining of the blanks for the middle case.

Right: each middle case of the watch was polished in the prototype workshop.

▶ 36 DAYS
BEFORE
THE DIVE

13 FEBRUARY TO 2 MARCH

THE UNIQUE FACE OF THE DIAL



While the prototype experts were busy cutting the steel and the titanium, a few steps away the dial of the ROLEX DEEPSEA CHALLENGE saw the light of day. It was developed and created by the cell devoted to dial design and development projects, a 10-person unit equipped with its own tools and machines to design and create dials autonomously and confidentially.

39,370 FT = 12,000 M

The base plates for the ROLEX DEEPSEA CHALLENGE dials were taken from the production run of the standard ROLEX DEEPSEA dials. The CHROMALIGHT hour markers in white gold with long-lasting luminescence were the same as on the ROLEX DEEPSEA.

The major difference was in the markings and their display: instead of Deepsea, the name Deepsea Challenge was placed on the circumference of the flange at 12 o'clock. At the bottom of the dial, the water-resistance guarantee numbers were changed to reflect the record depth, 39,370 ft = 12,000 m. They were also substantially enlarged, practically to the size of the Rolex logo on the dial, to emphasize the exceptional character of the piece.

NEW TAMPOGRAPHY

This rearrangement of the markings was the fruit of collaboration between the designer from the Design Department and the specialized graphic designer from the dial prototype workshop. A new tampography transfer – a process of transferring ink onto the dial using a silicone pad – had to be created.

A dial prototype expert made the new tampography printing plate, a steel plate engraved on the basis of a high-precision film. The marking was then printed onto the dial via tampography by a specialized operator from the prototype unit who also affixed the appliques. One week of work was necessary to create some 10 dials.

▶ 36 DAYS
BEFORE
THE DIVE

13 TO 24 FEBRUARY

SINGULAR CERACHROM INSERT

The deadline was non-negotiable
and failure was not an option.

days available (weekend included), the project seemed doable. The team set to work immediately. First step: manufacture the necessary tooling, notably the injection mould and the polishing device for an insert of that size, according to the plans supplied by the design engineers. This capacity to manufacture tools constitutes the key to the reactivity of the internal prototype teams. The material needed to produce large size inserts was available – the result of foresight and visionary planning – saving precious time. Within a mere two days, the tooling was ready.

MOMENT OF TRUTH

After the manufacturing, the final operation on the CERACHROM was the real moment of truth: the polishing, which reveals all the sheen of the ceramic. The prototype experts held their breath. The inserts were completed on D-Day at 8.57 a.m., three minutes before the set deadline expired and after two and a half weeks of intense work. They were rushed to the case assembly stage – just in time, but on time.

The CERACHROM insert on the rotatable bezel of the ROLEX DEEPSEA CHALLENGE proved to be a critical element in the making of this exclusive model.

FROM TOOLING TO FIRING

A special CERACHROM insert had to be produced to fit the larger diameter of the bezel. The principal challenge in making this

component was the ceramic manufacturing process, which requires long and incompressible time constraints. Everything got off to a good start. When the ROLEX DEEPSEA CHALLENGE design engineers sought the help of the ceramic specialists for a “priority” project, they warned them that the deadline was non-negotiable and that failure was not an option. After a quick calculation of the number of

13 TO 24 FEBRUARY

THE CROWN AND THE LASER



The Rolex crown emblem was engraved on the winding crown using cutting-edge laser technology.

The screw-down winding crown is one of the fundamental waterproof features of the OYSTER. The ROLEX DEEPSEA CHALLENGE has a TRIPLOCK crown with a triple waterproofness system similar to the one on the commercial divers' models, the ROLEX DEEPSEA and the SUBMARINER, but with a few particular characteristics.

First of all, its diameter is 10 mm on the experimental watch versus 8 mm on the commercial models. And, the crown tube (which links the crown to the inside of the case) is made of high-resistance nitrogen-alloyed steel, like the compression ring of the RINGLOCK System. Along with the other case components, these parts were manufactured by the prototype

workshop. As for the crown stem, it had to be adapted to the larger, 51.4-mm diameter of the case and manufactured specially in-house.

Laser soldering of the elements of the crown was carried out by the unit in charge of this delicate operation for the regular models. Once again, special tooling had to be created. The same team also created the marker on the rotatable bezel containing the luminescent capsule.

BLACK CROWN

A new laser engraving technology, which was under development in the prototype unit, was used to create the "DEEPSEA CHALLENGE" and "RING LOCK SYSTEM" inscriptions on the flange of the dial. The Rolex crown emblem and

the three dots designating the TRIPLOCK triple waterproofness system on the surface of the winding crown were engraved in black with the same cutting-edge laser technology, instead of being stamped in relief in the usual manner for standard production watches.

These steps demonstrate the extent to which innovative solutions were found to tackle myriad manufacturing challenges and produce this extraordinary model, which demanded contributions from each one of the Rolex sites.



Innovative solutions were found to tackle myriad manufacturing challenges.

20 FEBRUARY TO 2 MARCH

DIMENSIONS ARE EVERYTHING

One after the other, all the elements of the case took shape: the middle case, the case back, the components of the bezel and its CERACHROM insert, the compression ring of the RINGLOCK SYSTEM, the elements of the crown, as well as the various gaskets and the sapphire crystal.

But one more step was necessary before assembly in order to ensure the perfect integration of all the parts of the case: a strict dimensional control of the components, performed by the Development Department measurement centre.

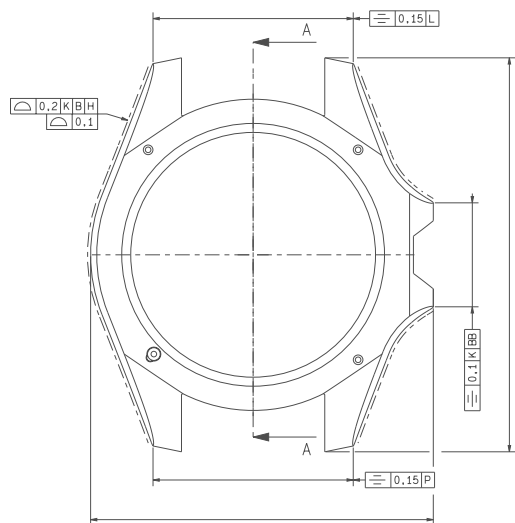

CONTROL AND PAIRING

These experts in precision use extremely reliable and accurate (to within one half of a micron) measuring instruments, equipped with multiple sensors (optical, mechanical, laser, etc). Their mission: to ensure that the parts produced correspond exactly to the design engineers' plans.

A prime responsibility, because the waterproofness and the ultimate resistance of the watch would depend on the conformity of the parts. To give their green light to production, these specialists literally waited in front of the machines for the first items to be machined in order to proceed to their measurements. Pressured by time, they concentrated on the accuracy of the functional dimensions, especially those linked to waterproofness and resistance, such as the flatness of the RINGLOCK SYSTEM's ring, the diameter of the middle case, case back and crown tube.

To ensure the precise fit of the components – a guarantee of the integrity of the watch – the measurement centre experts and the design engineers also paired them according to their dimensions, choosing the best dimensional combinations among the limited versions of the same item.



ASSEMBLY USING A PRESS

The different case components were assembled by the prototype experts. Using a press, the middle case and its clamping ring were friction fitted with extreme precision onto the RINGLOCK SYSTEM's compression ring, which had been previously fitted with the crystal and its gasket. The bezel assembly was also fitted. A specific key and support had to be developed to screw down the titanium case back onto the middle case. The five assembled cases were ready to receive their movements, before undergoing the ultimate pressure test at 1,500 bars in the "Mariannes" tank. The sixth case was spared the pressure test, considering its purely aesthetic purpose.

5 TO 9 MARCH

WATCHMAKERS UNDER PRESSURE

Rolex watchmakers are used to working on highly confidential special projects, and to finding the resourceful solutions needed to deal with complex and unusual situations. But for two of them, the latest mission was truly exceptional. It would be up to them to place movements in the oversized cases of the five ROLEX DEEPSEA CHALLENGE watches, to seal the case backs and to subject the watches to all of the standard Rolex functional and chronometric tests. An enormous responsibility considering that, as the last links in the chain, the whole project would hang on the quality of their work.

FITTING THE DIAL AND HANDS

They began their work one week before the departure of the watches for the Pacific island of Guam, where the final preparations for James Cameron's dive were due to take place. While waiting for each of the cases, which arrived one by one immediately after their assembly had been completed, the watchmakers began the delicate task of placing the dials and hands on the calibre 3135 movements. There was no room for error, for there were no spare dials. Dust is a formidable enemy in such an environment, to the extent that one of the watches had to be taken apart five times before it was considered in compliance with the required quality standards.

RESOURCEFUL WATCHMAKING

Up to this point in the casing, the watchmakers were able to use normal tools and procedures. The complications emerged when it came to placing the movements in the cases: the standard supports were not suited to the size of the experimental model's case. The watchmakers had to resort to a support that was specially made by the design engineers, as well as a large dose of their own resourcefulness.

The really tense moment came once the rotor was in place and it was time to seal the case back. Everything had to be impeccably clean: at the extreme pressure the watches would face, the slightest speck of dust on a gasket could generate a leak and compromise the water-proof seal.

When the first watch was tested, the tension in the room was palpable, as high as the pressure in the "Mariannes" tank: the design engineers, watchmakers and several other people involved in the project had gathered to attend the test. When the watch came out of the tank unscathed, everyone burst into applause.

When the first watch was tested, the tension in the room was palpable.



Specialist watchmakers dealt with the highly sensitive task of assembling each watch. From top to bottom: the dial is placed on the movement. The centre hands are placed on the dial. The movement and dial assembly are placed in the middle case. The winding crown is fitted.

▶ 17 DAYS
BEFORE
THE DIVE

9 MARCH

THE BRACELET, FINAL TESTS AND PACKAGING



The bracelet is fitted to a
ROLEX DEEPSEA CHALLENGE
watch.

After undergoing testing in the tank, the watches were once again checked and meticulously inspected by a quality specialist to detect any possible damage caused by the pressure. They also underwent a whole battery of chronometric precision tests lasting 24 hours.

The last step: the watchmakers fitted the bracelet, still under the watchful eye of the product quality expert who had been checking that the watches conformed to Rolex criteria at each step of the casing process – from the receipt of the components to the finished watch.

Finally, the time had come to place the watches in their presentation boxes for transport. Soon the five watches would take off for Guam with the small Rolex team whose mission would be to get the watches safely to their destination and supervise their installation on James Cameron's submersible, the *DEEPSEA CHALLENGER*.

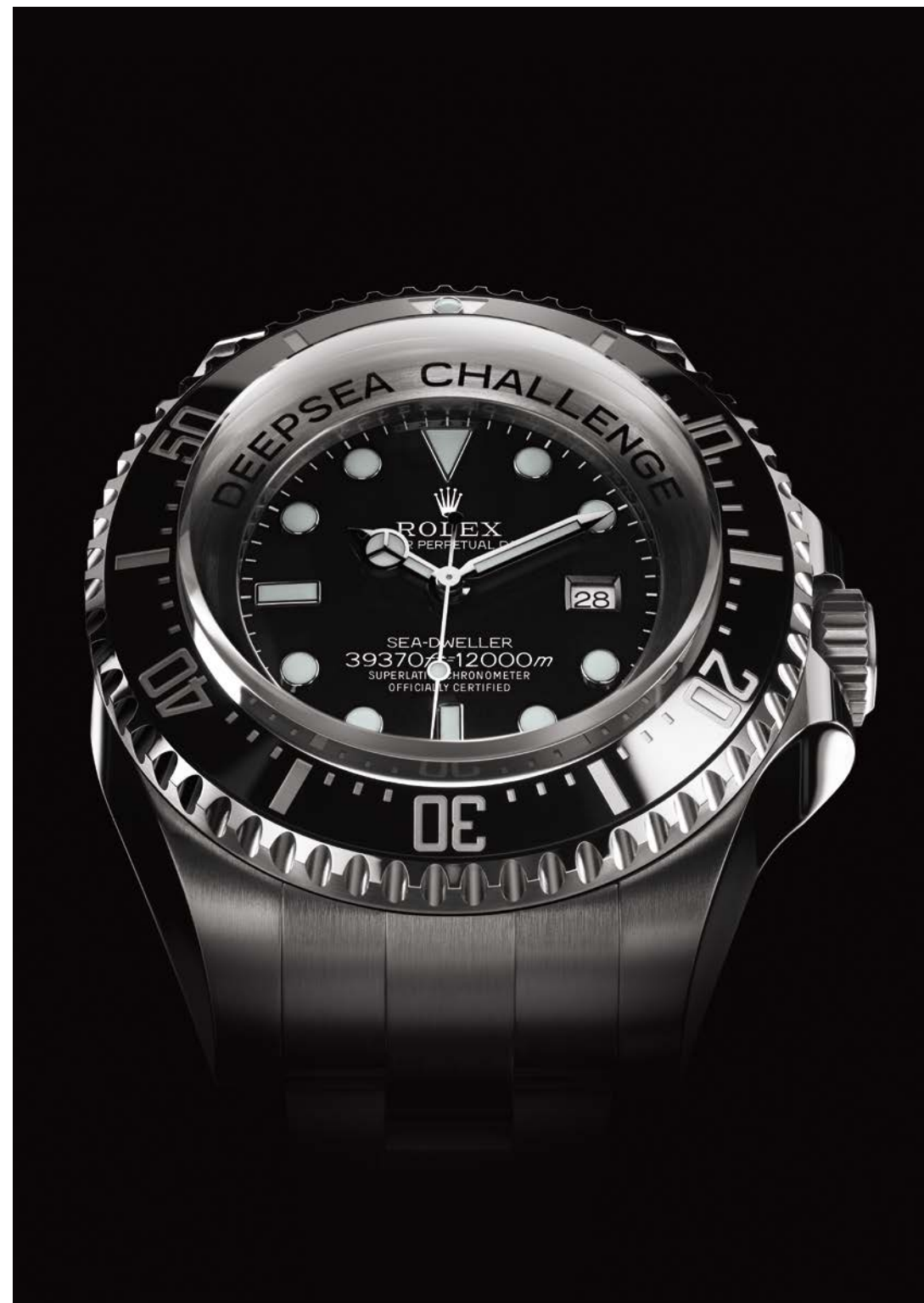

▶ THE DIVE

26 MARCH

05H23

TWENTY MINUTES AFTER THE *DEEPSEA CHALLENGER* IS LOWERED INTO THE WATER, JAMES CAMERON GIVES THE SIGNAL: "RELEASE, RELEASE, RELEASE!"

0-200 m: SUNLIGHT OR EPIPELAGIC ZONE

MOST OF THE LIFE IN THE OCEAN OCCURS HERE, IN THE WARMER SURFACE WATERS. APPROX. TEMP: 12 – 20° C



0-50 m

90 % of the ocean life lives here
Limit for recreational scuba divers on air

200-1000 m: TWILIGHT OR MESOPELAGIC ZONE

WITH DEPTH, SUNLIGHT FADES TO PITCH DARKNESS AND TEMPERATURES PLUNGE. APPROX. TEMP: 4 – 13° C

318 m

Deepest recorded scuba dive



300 m

Rolex SUBMARINER



600 m

Maximum dive depth of a nuclear submarine



▶ 05:23 AM
- 855 m

PRESSURE: 86.6 BARS
PRESSURE ON WATCH: 0.97 TONS



534 m

Deepest saturation dive by COMEX

1000-4000 m: MIDNIGHT ZONE
OR BATHYPELAGIC ZONE

BIOLUMINESCENCE PRODUCED BY ANIMALS
IS THE ONLY LIGHT. APPROX TEMP: 4°C



3800 m

Titanic's final resting place

4000-6000 m: ABYSSAL ZONE

MOST OF THE OCEAN FLOOR IS FOUND IN THIS RANGE
APPROX TEMP: NEAR FREEZING

4250 m

Average ocean depth

1300 m



Deepest diving turtle "Luth"

05:34 AM

- 2033 m

PRESSURE: 206 BARS

PRESSURE ON WATCH: 2.30 TONS



2500 m

Deepest diving Whale

05:50 AM

- 3550 m

PRESSURE: 359.7 BARS

PRESSURE ON WATCH: 4.02 TONS



3900 m

ROLEX DEEPSEA

07H46

MISSION ACCOMPLISHED



“I felt like, literally in the space of one day, I had gone to another planet and come back.” James Cameron

Thanks to their perseverance, dedication and commitment to perfection, the team at Rolex achieved the impossible. In just over four weeks, they designed, engineered, manufactured and tested a unique experimental model, the ROLEX DEEPSEA CHALLENGE, overcoming significant challenges on the way and meeting the toughest of deadlines. Yet, it was still too early to celebrate. The true celebration came when the watch proved itself under real-life conditions, emerging from the depths of Challenger Deep in perfect condition – a formidable mission accomplished.

6000 m PLUS: THE TRENCHES
OR HADAL ZONE

FOOD IS SCARCE, BUT NEW LIFE IS STILL FOUND IN
THIS HARSH ENVIRONMENT
APPROX TEMP: JUST ABOVE FREEZING



7700 m

The snailfish: the deepest-living
fish ever filmed

8848 m

Mount Everest... inverted

JIM CAMERON:
“JUST ARRIVED AT
OCEAN’S DEEPEST POINT.
HITTING BOTTOM
NEVER FELT SO GOOD.
CAN’T WAIT TO SHARE
WHAT I AM SEEING
WITH YOU.”

07:46 AM

-10'908 m
DEPTH REACHED

PRESSURE: 1104.2 BARS

PRESSURE ON WATCH: 12.35 TONS





ABOUT ROLEX

Rolex, the leading brand of the Swiss watch industry, is headquartered in Geneva and enjoys an unrivalled reputation for quality and expertise the world over. Its Oyster watches, all certified as Superlative Chronometers for their precision, performance and reliability, are symbols of excellence, elegance and prestige. Founded by Hans Wilsdorf in 1905, the brand pioneered the development of the wristwatch and is at the origin of numerous major watchmaking innovations, such as the Oyster, the first waterproof wristwatch, launched in 1926, and the Perpetual rotor self-winding mechanism invented in 1931. Rolex has registered over 400 patents in the course of its history. A truly integrated and independent manufacturing company, Rolex designs, develops and produces all the essential components of its watches in-house, from the casting of the gold alloys to the machining, crafting, assembly and finishing of the movement, case, dial and bracelet. Rolex is also actively involved in supporting the arts, sports, exploration, the spirit of enterprise, and the environment through a broad palette of sponsoring activities as well as philanthropic programmes.

CONTACT

PRESS AND PUBLIC RELATIONS

Virginie Chevailler

COMMUNICATION & IMAGE

ROLEX SA - rue François-Dussaud, 3-5-7

1211 Geneva 26 – Switzerland

Tel.: +41 22 302 22 00

Email: virginie.chevailler@rolex.com

OFFICIAL SITES

rolex.com

deepseachallenge.com



COPYRIGHT

©Rolex/Jean-Daniel Meyer; ©Rolex; ©Mark Thiessen/National Geographic; ©Rolex/Victor Consaga; ©Great Wight Productions Pty Ltd/Earthship Productions, Inc; ©National Geographic; ©Keystone/Len Sirman Archiv/Str; ©Rolex/Jess Hoffman; ©Getty Images/Chris Ross